

## ON THE SET OF PERIODS OF SIGMA MAPS OF DEGREE 1

LLUÍS ALSÈDÀ AND SYLVIE RUETTE

ABSTRACT. We study the set of periods of degree 1 continuous maps from  $\sigma$  into itself, where  $\sigma$  denotes the space shaped like the letter  $\sigma$  (i.e., a segment attached to a circle by one of its endpoints). Since the maps under consideration have degree 1, the rotation theory can be used. We show that, when the interior of the rotation interval contains an integer, then the set of periods (of periodic points of any rotation number) is the set of all integers except maybe 1 or 2. We exhibit degree 1  $\sigma$ -maps  $f$  whose set of periods is a combination of the set of periods of a degree 1 circle map and the set of periods of a 3-star (that is, a space shaped like the letter  $Y$ ). Moreover, we study the set of periods forced by periodic orbits that do not intersect the circuit of  $\sigma$ ; in particular, when there exists such a periodic orbit whose diameter, at lifting level, is at least 1, then there exist periodic points of all periods.

### 1. INTRODUCTION

In this paper, we want to study the set of periods of continuous maps from the space  $\sigma$  to itself. The space  $\sigma$  is the topological graph that consists of a circle with a segment attached to it at one of its endpoints.

The motivation for this problem is to progress in the direction started with Sharkovsky’s Theorem [20, 21] with the characterisation of the sets of periods of continuous interval maps and continued to the circle [14, 13, 19], trees [2, 3, 5, 4, 12, 6, 11] and other graphs [16, 17].

A full characterisation of the sets of periods for continuous self maps of the graph  $\sigma$  having the branching fixed is given in [16]. Our goal is to extend this result to the general case. The most natural approach is to follow the strategy used in the circle case which consists in dividing the problem according to the degree of the map [14, 13, 19]. The cases considered for the circle are degree different from  $\{-1, 0, 1\}$ , and separately the cases of degree 0,  $-1$  and 1. A characterisation of the set of periods of the class of continuous maps from the space  $\sigma$  to itself with degree different from  $\{-1, 0, 1\}$  can be found in [18]. In this paper, we aim at studying the set of periods of continuous  $\sigma$ -maps of degree 1. Following again the strategy of the circle case, we shall work at the lifting level and we shall use rotation theory. This theory for graphs with a single circuit was developed in [8]; the current paper is thus an application of the theory developed there.

We shall follow three main directions for studying the set of periods of  $\sigma$ -maps. The first very natural one follows from the trivial observation that the space  $\sigma$  contains both a circle and a subset homeomorphic to a  $Y$  (also called a 3-star). It is quite obvious that there exist  $\sigma$ -maps of degree 1 whose set of periods is equal to the set of periods of any given degree 1 circle map, as well as the set of periods of any given 3-star map. We shall show that there exist  $\sigma$ -maps  $f$  whose set of periods is any combination of both kinds of sets, provided that 0 is an endpoint of the rotation interval of  $f$ : the whole rotation interval gives a set of periods as for circle maps whereas the set of periods of a given 3-star map appears with rotation number 0.

The second direction is the study of periodic orbits that do not intersect the circuit of the space  $\sigma$ ; this study is necessary because the rotation interval does not capture well the behaviours of such orbits. We shall show that the existence of such a periodic orbit of period  $n$  implies all periods less than  $n$  for the Sharkovsky ordering; this is quite natural because this ordering rules the sets of periods of interval maps and the branch of  $\sigma$  is an interval. Moreover, we shall show

---

The first author has been partially supported by the MINECO grants number MTM2008-01486 and MTM2011-26995-C02-01. Both authors thank kind invitations of the *Laboratoire de Mathématiques, Université Paris-Sud 11* and *Departament de Matemàtiques, Universitat Autònoma de Barcelona* that made this paper possible.

that if, at lifting level, there exists a periodic orbit living in the branches and with diameter greater than or equal to 1, then the set of periods contains necessarily all integers.

The third direction focuses on the rotation number 0. For degree 1 circle maps, the strategy is to characterise the set of periods for a given rotation number  $p/q$  in the interior of the rotation interval, which comes down to do the same for the rotation number 0 for another map. Unfortunately, mimicking this strategy fails for  $\sigma$ -maps because the set of periods of rotation number 0 can be complicated and we do not know how to describe it. However, we shall characterise the set of periods (of any rotation number) when 0 is in the interior of the rotation interval of a  $\sigma$  map: in this case, the set of periods is, either  $\mathbb{N}$ , or  $\mathbb{N} \setminus \{1\}$ , or  $\mathbb{N} \setminus \{2\}$ .

Moreover, we shall stress some difficulties that appear when one tries to follow the same strategy as for degree 1 circle maps.

In the next section, we state and discuss the main results of the paper, after introducing the necessary notation to formulate them.

## 2. DEFINITIONS AND STATEMENTS OF THE MAIN RESULTS

**2.1. Covering space of  $\sigma$ , periodic (mod 1) points, rotation set.** As it has been said, we shall work at the lifting level and we shall use the rotation theory developed in [8]. We also shall consider periodic (mod 1) points and orbits instead of the true ones. The results obtained in this setting can be obviously pulled back to the original map and space.

We start by introducing the framework to use the rotation theory developed in [8].

We consider the universal covering of  $\sigma$ . More precisely, we take the following space (see Figure 1)

$$S = \mathbb{R} \cup B,$$

where

$$B := \{z \in \mathbb{C} : r(z) \in \mathbb{Z} \text{ and } \text{Im}(z) \in [0, 1]\}$$

and  $r(z)$  and  $\text{Im}(z)$  denote respectively the real and imaginary part of a complex number  $z$ . The set  $B$  is called the *set of branches of  $S$* .

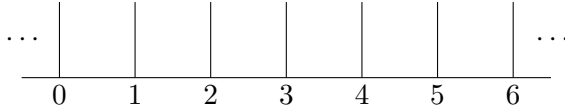

FIGURE 1. The space  $S$ , universal covering of  $\sigma$ .

Observe that  $S = S + \mathbb{Z} = \{x + k : x \in S \text{ and } k \in \mathbb{Z}\}$  (since  $S \subset \mathbb{C}$ , the operation  $+$  is just the usual one in  $\mathbb{C}$ ). Moreover, the real part function defines a retraction from  $S$  to  $\mathbb{R}$ . That is,  $r(x) = x$  for every  $x \in \mathbb{R}$  and, when  $x \in S \setminus \mathbb{R}$ , then  $r(x)$  gives the integer in the base of the segment where  $x$  lies.

For every  $m \in \mathbb{Z}$ , we set

$$B_m := \{z \in S : r(z) = m \text{ and } \text{Im}(z) \in [0, 1]\} = S \cap r^{-1}(m), \text{ and}$$

$$\mathring{B}_m := B_m \setminus \{m\}.$$

Each of the sets  $B_m$  is called a *branch of  $S$* . Clearly,  $B = \cup_{m \in \mathbb{Z}} B_m$ ,  $B_m \cap \mathbb{R} = \{m\}$  and  $\mathring{B}_m \cap \mathbb{R} = \emptyset$ . Each branch  $B_m$  is endowed with a linear ordering  $\leq$  as follows. If  $x, y \in B_m$ , we write  $x < y$  if and only if  $\text{Im}(x) < \text{Im}(y)$ .

In what follows,  $\mathcal{L}_d(S)$  will denote the class of continuous maps  $F$  from  $S$  into itself of degree  $d \in \mathbb{Z}$ , that is,  $F(x+1) = F(x) + d$  for all  $x \in S$ . We also set  $\mathcal{L}(S) = \cup_{d \in \mathbb{Z}} \mathcal{L}_d(S)$ . Observe that  $r \in \mathcal{L}_1(S)$  and thus, if  $F \in \mathcal{L}_1(S)$ , then  $r \circ F^n \in \mathcal{L}_1(S)$  for every  $n \in \mathbb{N}$ .

Let  $F \in \mathcal{L}(S)$  and  $x \in S$ . The set

$$\{F^n(x) + m : n \geq 0 \text{ and } m \in \mathbb{Z}\}$$

is called the *orbit (mod 1) of  $x$* , and denoted by  $\text{Orb}_1(x, F)$ . The point  $x$  is called *periodic (mod 1)* if there exists  $n \in \mathbb{N}$  such that  $F^n(x) \in x + \mathbb{Z}$ . The *period (mod 1)* of  $x$  is the least positive integer  $n$  satisfying this property, that is,  $F^n(x) \in x + \mathbb{Z}$  and  $F^i(x) \notin x + \mathbb{Z}$  for all  $1 \leq i \leq n - 1$ . When  $x$  is periodic (mod 1), then  $\text{Orb}_1(x, F)$  is also called a *periodic (mod 1) orbit*. It is not difficult to see that, for all  $k \in \mathbb{Z}$ ,  $\text{Card}(\text{Orb}_1(x, F) \cap r^{-1}([k, k + 1]))$  coincides with the period (mod 1) of  $x$  (where  $\text{Card}(\cdot)$  denotes the cardinality of a finite set). The set of all periods of the periodic (mod 1) points of  $F \in \mathcal{L}(S)$  will be denoted by  $\text{Per}(F)$ .

Given a space  $X$  and a map  $f: X \rightarrow X$ , we say that a point  $x \in X$  is *periodic of period  $n$*  if  $f^n(x) = x$  and  $f^i(x) \neq x$  for all  $i = 1, 2, \dots, n - 1$ . Moreover, for every  $x \in X$ , the set

$$\text{Orb}(x, f) := \{f^n(x) : n \geq 0\},$$

is called the *orbit of  $x$* . Observe that if  $x$  is periodic with period  $n$ , then  $\text{Card}(\text{Orb}(x, f)) = n$ . The set of periods of all periodic points of  $f$  will be denoted by  $\text{Per}^\circ(f)$ . We shall sometimes write *true period* or *true periodic point* to emphasise that they are not (mod 1).

Let  $\pi: S \rightarrow \sigma$  be the standard projection from  $S$  to  $\sigma$ , that is,  $\pi|_{r^{-1}([0,1])}$  is continuous onto and one-to-one and  $\pi(x) = \pi(x + k)$  for all  $x \in S$  and all  $k \in \mathbb{Z}$ . Clearly, for every  $F \in \mathcal{L}(S)$ ,  $\pi(F) := \pi \circ F \circ \pi^{-1}$  is a well defined continuous self map of  $\sigma$ . Reciprocally, for every continuous map  $f$  from  $\sigma$  into itself, there exists a lifting  $F \in \mathcal{L}(S)$  such that  $\pi(F) = f$ , and this lifting is unique up to an integer (that is, if  $G$  is another lifting, there exists  $k \in \mathbb{N}$  such that  $G = F + k$ ). Moreover,  $x$  is a periodic (mod 1) point of  $F$  of period  $n$  if and only if  $\pi(x)$  is a periodic point of  $\pi(F)$  of (true) period  $n$ ,  $\pi(\text{Orb}_1(x, F)) = \text{Orb}(\pi(x), \pi(F))$ . Consequently,  $\text{Per}(F) = \text{Per}^\circ(\pi(F))$  and characterising the sets of periods (mod 1) of maps from  $\mathcal{L}(S)$  is equivalent to characterising the sets of periods of continuous self maps of  $\sigma$ .

This paper will deal with maps of degree 1, for which rotation numbers can be defined. Next we recall the notion of rotation number in our setting and its basic properties.

**Definition 2.1.** Let  $F \in \mathcal{L}_1(S)$  and  $x \in S$ . We define the *rotation number of  $x$*  as

$$\rho_F(x) := \lim_{n \rightarrow +\infty} \frac{r \circ F^n(x) - r(x)}{n}$$

if the limit exists. We also define the following *rotation sets of  $F$* :

$$\begin{aligned} \text{Rot}(F) &= \{\rho_F(x) : x \in S\}, \\ \text{Rot}_{\mathbb{R}}(F) &= \{\rho_F(x) : x \in \mathbb{R}\}. \end{aligned}$$

◇

For every  $x \in S$ ,  $k \in \mathbb{Z}$  and  $n \in \mathbb{N}$ , it follows that  $\rho_F(x + k) = \rho_F(x)$ ,  $\rho_{(F+k)}(x) = \rho_F(x) + k$  and  $\rho_{F^n}(x) = n\rho_F(x)$  (c.f [8, Lemma 1.10]). The second property implies that, if  $F, G$  are two liftings of the same continuous map from  $\sigma$  into itself, then their rotation sets differ from an integer ( $\exists k \in \mathbb{Z}$  such that  $G = F + k$ , and hence  $\text{Rot}(G) = \text{Rot}(F) + k$ ).

Unfortunately, the set  $\text{Rot}(F)$  need not be connected as it has been shown in [8]. However, the set  $\text{Rot}_{\mathbb{R}}(F)$ , which is a subset of  $\text{Rot}(F)$ , has better properties. Next result is [8, Theorem 3.1].

**Theorem 2.2.** *For every  $F \in \mathcal{L}_1(S)$ ,  $\text{Rot}_{\mathbb{R}}(F)$  is a non empty compact interval. Moreover, if  $\alpha \in \text{Rot}_{\mathbb{R}}(F)$ , then there exists a point  $x \in \mathbb{R}$  such that  $\rho_F(x) = \alpha$  and  $F^n(x) \in \mathbb{R}$  for infinitely many  $n$ . If  $p/q \in \text{Rot}_{\mathbb{R}}(F)$ , then there exists a periodic (mod 1) point  $x \in S$  with  $\rho_F(x) = p/q$ .*

**Definition 2.3.** Given  $F \in \mathcal{L}_1(S)$  and  $\alpha \in \mathbb{R}$ , let  $\text{Per}(\alpha, F)$  denote the set of periods of all periodic (mod 1) points of  $F$  whose rotation number is  $\alpha$ . ◇

It is easy to see that every periodic (mod 1) point has a rational rotation number (see also Lemma 3.1(e)). Therefore, Theorem 2.2 implies that, when  $\alpha \in \text{Rot}_{\mathbb{R}}(F)$ ,  $\text{Per}(\alpha, F)$  is non-empty if and only if  $\alpha \in \mathbb{Q}$ .

Observe that the class of maps  $F \in \mathcal{L}_1(S)$  such that  $F(\mathbb{R}) \subset \mathbb{R}$  and  $F(B_m) = F(m)$  for every  $m \in \mathbb{Z}$  can be identified with the class of liftings of continuous circle maps of degree 1. Therefore any possible set of periods of a continuous circle map of degree 1 can be a set of periods of a

map in  $\mathcal{L}_1(S)$ . On the other hand, set  $Y_0 := B_0 \cup [-1/3, 1/3]$  (this space is called a *3-star*) and consider the class of maps  $F \in \mathcal{L}_1(S)$  such that  $F(Y_0) \subset Y_0$ ,  $F(x) \in Y_0 \cup [1/3, x]$  for every  $x \in [1/3, 1/2)$  and  $F(x) \in (Y_0+1) \cup (x, 2/3]$  for every  $x \in (1/2, 2/3]$  (in particular  $F(1/2) = 1/2$ ). This implies that  $\text{Per}(F) = \text{Per}^\circ(F|_{Y_0})$  and thus, every possible set of periods of a map from a 3-star into itself can be a set of periods of a map from  $\mathcal{L}_1(S)$ . Clearly, this includes the sets of periods of interval maps. Moreover, it might happen that this phenomenon occurs for rotation numbers different from 0, that is, there may exist a map from  $\mathcal{X}_3$  with set of periods  $A \subset \mathbb{N}$ ,  $p \in \mathbb{Z}$ ,  $q \in \mathbb{N}$  and  $\tilde{S} \subset S$  such that  $\text{Per}^\circ((F^q - p)|_{\tilde{S}}) = A$  and  $\text{Per}(p/q, F) = q \cdot \text{Per}^\circ((F^q - p)|_{\tilde{S}})$ . Therefore, a natural conjecture for the structure of the set of periods of maps from  $\mathcal{L}_1(S)$  could be that it is the union of the set of periods of a circle map of degree 1 with some sets of the form  $q \cdot \text{Per}^\circ(f)$  with  $q \in \mathbb{N}$  and  $f \in \mathcal{X}_3$  much in the spirit of the characterisation of the set of periods for circle maps of degree one. We shall see that it is unclear that all possibilities can occur.

To explain these ideas in detail, and to state the main results of the paper, we need to recall the characterisation of the sets of periods of circle maps of degree 1 and of star maps. We are going to do this in the next two subsections; we shall also introduce the necessary notations.

**2.2. Tree maps.** A *tree* is a compact uniquely arcwise connected space which is a point or a union of a finite number of segments glued together at some of their endpoints (by a *segment* we mean any space homeomorphic to  $[0, 1]$ ). Any continuous map  $f$  from a tree into itself is called a *tree map*. The space  $S$  is often called an infinite tree by similarity.

Consider a tree  $T$  or the space  $S$ . For every  $x$  in  $T$  or  $S$ , the *valence* of  $x$  is the number of connected components of  $T \setminus \{x\}$ . A point of valence different from 2 is called a *vertex*. A point of valence 1 is called an *endpoint*. The points of valence greater than or equal to 3 (that is, vertices that are not endpoints) are called the *branching points*. If  $K$  is a subset of  $T$  or  $S$ , then  $\langle K \rangle$  denotes the *convex hull* of  $K$ , that is, the smallest closed connected set containing  $K$  (which is well defined since the trees and the space  $S$  are uniquely arcwise connected). An *interval* in  $T$  or  $S$  is any subset homeomorphic to an interval of  $\mathbb{R}$ . For a compact interval  $I$ , it is equivalent to say that there exist two points  $a, b$  such that  $I = \langle a, b \rangle$ ; in this case,  $\{a, b\} = \text{Bd}(I)$  (where  $\text{Bd}(\cdot)$  denotes the boundary of a set). When a distance is needed in a tree or  $S$ , we use a taxicab metric, that is, a distance  $d$  such that, if  $z \in \langle x, y \rangle$ , then  $d(x, y) = d(x, z) + d(z, y)$ . In  $S$ , the distance is simply defined by

$$\forall x, y \in S, d(x, y) = \begin{cases} |x - y| & \text{if } x, y \in B_m \text{ for some } m \in \mathbb{Z}, \\ |x - r(x)| + |r(x) - r(y)| + |y - r(y)| & \text{otherwise.} \end{cases}$$

Consider a compact interval  $I$  in an tree  $T$  or in  $S$ , and a continuous map  $f: I \rightarrow S$ . We say that  $f$  is *monotone* if, either  $f(I)$  is reduced to one point, or  $f(I)$  is a non degenerate interval and, given any homeomorphisms  $h_1: [0, 1] \rightarrow I$ ,  $h_2: [0, 1] \rightarrow f(I)$ , the map  $h_2^{-1} \circ f \circ h_1: [0, 1] \rightarrow [0, 1]$  is monotone. We say that  $f$  is *affine* if  $f(I)$  is an interval and there exists a constant  $\lambda$  such that  $\forall x, y \in I$ ,  $d(f(x), f(y)) = \lambda d(x, y)$ .

A tree that is a union of  $n \geq 2$  segments whose intersection is a unique point  $y$  of valence  $n$  is called an *n-star*, and  $y$  is called its *central point*. For a fixed  $n$ , all  $n$ -stars are homeomorphic. In what follows,  $X_n$  will denote an  $n$ -star,  $\mathcal{X}_n$  the class of all continuous maps from  $X_n$  to itself and  $\mathcal{X}_n^\circ$  the class of all maps from  $\mathcal{X}_n$  that leave the unique branching point of  $X_n$  fixed.

A crucial notion for periodic orbits of maps in  $\mathcal{X}_n$  is the *type* of an orbit [10]. Let  $f \in \mathcal{X}_n$  and let  $P$  be a periodic orbit of  $F$ . Let  $y$  denote the branching point of  $X_n$ . If  $y \in P$ , then we say that  $P$  has *type 1*. Otherwise, let  $\text{Br}$  be the set of branches of  $X_n$  that intersect  $P$  (by a branch we mean a connected component of  $X_n \setminus \{y\}$ ). For each  $b \in \text{Br}$  we denote by  $\text{sm}_b$  the point of  $P \cap b$  closest to  $y$  (that is,  $\text{sm}_b \in b$  and  $\langle y, \text{sm}_b \rangle \cap P = \{\text{sm}_b\}$ ). Then we define a map  $\phi: \text{Br} \rightarrow \text{Br}$  by letting  $\phi(b)$  be the branch of  $\text{Br}$  containing  $f(\text{sm}_b)$ . Since  $\text{Br}$  is a finite set,  $\phi$  has periodic orbits. Each period of a periodic orbit of  $\phi$  is called a *type* of  $P$ . Clearly the type may not be unique. However, it is clearly unique in the case when  $P$  has type  $n$ .

We shall also speak of the type of a (true) periodic orbit  $P$  of a map  $F \in \mathcal{L}_1(S)$  such that  $\langle P \rangle$  is homeomorphic to  $X_n$  (indeed  $X_3$ ). The definition of type extends straightforwardly to this situation.

We now recall the Sharkovsky total ordering and Baldwin partial orderings, which are needed to state the characterisation of the sets of periods of star maps.

The *Sharkovsky ordering*  $\leq_{\text{Sh}}$  is defined on  $\mathbb{N}_{\text{Sh}} = \mathbb{N} \cup \{2^\infty\}$  by:

$$\begin{aligned} 3_{\text{Sh}} &> 5_{\text{Sh}} > 7_{\text{Sh}} > \dots > 2 \cdot 3_{\text{Sh}} > 2 \cdot 5_{\text{Sh}} > 2 \cdot 7_{\text{Sh}} > \dots \\ 2^2 \cdot 3_{\text{Sh}} &> 2^2 \cdot 5_{\text{Sh}} > 2^2 \cdot 7_{\text{Sh}} > \dots > \dots \\ 2^\infty_{\text{Sh}} &> \dots > 2^n_{\text{Sh}} > \dots > 2^4_{\text{Sh}} > 2^3_{\text{Sh}} > 2^2_{\text{Sh}} > 2_{\text{Sh}} > 1. \end{aligned}$$

That is, this ordering starts with all the odd numbers greater than 1, in increasing order, then 2 times the odd numbers  $> 1$ , then  $2^2$  times,  $2^3$  times,  $\dots$ ,  $2^n$  times the odd numbers  $> 1$ ; finally the last part of the ordering consists of all powers of 2 in decreasing order; the symbol  $2^\infty$  being greater than all powers of 2 and  $1 = 2^0$  being the smallest element.

For every integer  $t \geq 2$ , let  $\mathbb{N}_t$  denote the set  $(\mathbb{N} \cup \{t \cdot 2^\infty\}) \setminus \{2, 3, \dots, t-1\}$  and  $\mathbb{N}_t^\vee := \{mt : m \in \mathbb{N}\} \cup \{1, t \cdot 2^\infty\}$ . Then the *Baldwin partial ordering*  $\leq_t$  is defined in  $\mathbb{N}_t$  as follows. For all  $k, m \in \mathbb{N}_t$ , we write  $k \leq_t m$  if one of the following cases holds:

- (i)  $k = 1$  or  $k = m$ ,
- (ii)  $k, m \in \mathbb{N}_t^\vee \setminus \{1\}$  and  $m/t_{\text{Sh}} > k/t$ ,
- (iii)  $k \in \mathbb{N}_t^\vee$  and  $m \notin \mathbb{N}_t^\vee$ ,
- (iv)  $k, m \notin \mathbb{N}_t^\vee$  and  $k = im + jt$  with  $i, j \in \mathbb{N}$ ,

where in case (ii) we use the following arithmetic rule for the symbol  $t \cdot 2^\infty$ :  $t \cdot 2^\infty / t = 2^\infty$ .

There are two parts in the structure of the orderings  $\leq_t$ . The smallest part consists of all elements of  $\mathbb{N}_t^\vee$  ordered as follows. The smallest element is 1. Then all the multiples of  $t$  (including  $t \cdot 2^\infty$ ) come in the ordering induced by the Sharkovsky ordering and the largest element of  $\mathbb{N}_t^\vee$  is  $3 \cdot t$ . Then the ordering  $\leq_t$  divides  $\mathbb{N}_t \setminus \mathbb{N}_t^\vee$  into  $t-1$  ‘‘branches’’. The  $l$ -th branch ( $l \in \{1, 2, \dots, t-1\}$ ) is formed by all positive integers (except  $l$ ) which are congruent to  $l$  modulo  $t$  in decreasing order. All elements of these branches are larger than all elements of  $\mathbb{N}_t^\vee$ .

We note that, by means of the inclusion of the symbol  $t \cdot 2^\infty$ , each subset of  $\mathbb{N}_t$  has a maximal element with respect to the ordering  $\leq_t$ . We also note that the ordering  $\leq_2$  on  $\mathbb{N}_2$  coincides with the Sharkovsky ordering on  $\mathbb{N}_{\text{Sh}}$  (by identifying the symbol  $2 \cdot 2^\infty$  with  $2^\infty$ ).

A non empty set  $A \subset \mathbb{N}_t \cap \mathbb{N}$  is called a *tail of the ordering*  $\leq_t$  if, for all  $m \in A$ , we have  $\{k \in \mathbb{N} : k \leq_t m\} \subset A$ . Moreover, for all  $s \in \mathbb{N}_{\text{Sh}}$ ,  $\text{Ssh}(s)$  denotes the initial segment of the Sharkovsky ordering starting at  $s$ , that is,  $\text{Ssh}(s) = \{k \in \mathbb{N} : k \leq_{\text{Sh}} s\}$ .

The following result, due to Baldwin [10], characterises the set of periods of star maps.

**Theorem 2.4.** *Let  $f \in \mathcal{X}_n$ . Then  $\text{Per}^\circ(f)$  is a finite union of tails of the orderings  $\leq_t$  for all  $t \in \{2, \dots, n\}$  (in particular,  $1 \in \text{Per}^\circ(f)$ ). Conversely, if a non empty set  $A$  can be expressed as a finite union of tails of the orderings  $\leq_t$  with  $2 \leq t \leq n$ , then there exists a map  $f \in \mathcal{X}_n$  such that  $\text{Per}^\circ(f) = A$ .*

Note that the case  $n = 2$  in the above theorem is, indeed, Sharkovsky’s Theorem for interval maps [20]. Moreover, since every tail of  $\leq_t$  contains  $1 \in \text{Per}^\circ(f)$ , then the order  $\leq_t$  does not contribute to  $\text{Per}^\circ(f)$  if the tail with respect to  $\leq_t$  in the above lemma is reduced to  $\{1\}$ .

**2.3. Circle maps of degree 1.** Let  $\mathbb{S}^1$  be the unit circle in the complex plane, that is,  $\mathbb{S}^1 = \{z \in \mathbb{C} : |z| = 1\}$ , and let  $\mathcal{L}_1(\mathbb{R})$  denote the class of all liftings of continuous circle maps of degree one. If  $F \in \mathcal{L}_1(\mathbb{R})$ ,  $\text{Rot}(F)$  denotes the rotation set of  $F$  and, by [15], is a compact non empty interval.

To study the connection between the set of periods and the rotation interval, we need some additional notation. For all  $c \leq d$ , we set  $M(c, d) := \{n \in \mathbb{N} : c < k/n < d \text{ for some integer } k\}$ .

Notice that we do not assume here that  $k$  and  $n$  are coprime. Obviously,  $M(c, d) = \emptyset$  if and only if  $c = d$ . Given  $\rho \in \mathbb{R}$  and  $S \subset \mathbb{N}$ , we set

$$\Lambda(\rho, S) = \begin{cases} \emptyset & \text{if } \rho \notin \mathbb{Q}, \\ \{nq : q \in S\} & \text{if } \rho = k/n \text{ with } k \text{ and } n \text{ coprime.} \end{cases}$$

The next theorem recalls Misiurewicz's characterisation of the sets of periods for degree 1 circle maps (see [19, 7]).

**Theorem 2.5.** *Let  $F \in \mathcal{L}_1(\mathbb{R})$ , and let  $\text{Rot}(F) = [c, d]$ . Then there exist numbers  $s_c, s_d \in \mathbb{N}_{\text{Sh}}$  such that  $\text{Per}(F) = \Lambda(c, \text{Ssh}(s_c)) \cup M(c, d) \cup \Lambda(d, \text{Ssh}(s_d))$ . Conversely, for all  $c, d \in \mathbb{R}$  with  $c \leq d$  and all  $s_c, s_d \in \mathbb{N}_{\text{Sh}}$ , there exists a map  $F \in \mathcal{L}_1(\mathbb{R})$  such that  $\text{Rot}(F) = [c, d]$  and  $\text{Per}(F) = \Lambda(c, \text{Ssh}(s_c)) \cup M(c, d) \cup \Lambda(d, \text{Ssh}(s_d))$ .*

**2.4. Statement of main results.** In view of what we said at the end of Subsection 2.1, a reasonable conjecture about the set of periods for maps from  $\mathcal{L}_1(S)$  could be the following:

**Conjecture A.** *Let  $F \in \mathcal{L}_1(S)$  be with  $\text{Rot}_{\mathbb{R}}(F) = [c, d]$ . Then there exist sets  $E_c, E_d \subset \mathbb{N}$  which are finite unions of tails of the orderings  $\leq_2$  and  $\leq_3$  such that*

$$\text{Per}(F) = \Lambda(c, E_c) \cup M(c, d) \cup \Lambda(d, E_d).$$

*Conversely, given  $c, d \in \mathbb{R}$  with  $c \leq d$ , and non empty sets  $E_c, E_d \subset \mathbb{N}$  which are finite union of tails of the orderings  $\leq_2$  and  $\leq_3$ , there exists a map  $F \in \mathcal{L}_1(S)$  such that  $\text{Rot}_{\mathbb{R}}(F) = [c, d]$  and*

$$\text{Per}(F) = \Lambda(c, E_c) \cup M(c, d) \cup \Lambda(d, E_d).$$

As we shall see, some facts seem to indicate that this conjecture is not entirely true (though they do not disprove it). However, we shall use this conjecture as a guideline: on the one hand, we shall prove that it is partly true; on the other hand, we shall stress some difficulties.

We start by discussing the second statement of Conjecture A. This statement holds in two particular cases, stated in Corollary B and Theorem C below. The first one is an easy corollary of Theorem 2.5 and the second one deals with the particular case when 0 is an endpoint of the rotation interval. Recall that  $\leq_2$  coincide with  $\leq_{\text{Sh}}$ .

**Corollary B.** *Given  $c, d \in \mathbb{R}$  with  $c \leq d$  and  $s_c, s_d \in \mathbb{N}_{\text{Sh}}$ , there exists a map  $F \in \mathcal{L}_1(S)$  such that  $\text{Rot}_{\mathbb{R}}(F) = [c, d]$  and  $\text{Per}(F) = \Lambda(c, \text{Ssh}(s_c)) \cup M(c, d) \cup \Lambda(d, \text{Ssh}(s_d))$ .*

Notice that, when both  $c$  and  $d$  are irrational, Corollary B implies the second statement of Conjecture A. Therefore it remains to consider the cases when  $c$  and/or  $d$  are in  $\mathbb{Q}$  and when the order  $\leq_3$  is needed (or equivalently when one refers to the set of periods of any 3-star map). The next theorem deals with the case when  $c$  (or  $d$ ) is equal to 0 (or, equivalently, to an integer) and  $\leq_3$  is needed only for this endpoint.

**Theorem C.** *Let  $d \neq 0$  be a real number,  $s_d \in \mathbb{N}_{\text{Sh}}$  and  $f \in \mathcal{X}_3$ . Then there exists a map  $F \in \mathcal{L}_1(S)$  such that  $\text{Rot}_{\mathbb{R}}(F) = \text{Rot}(f)$  is the closed interval with endpoints 0 and  $d$  (i.e.,  $[c, d]$  or  $[d, c]$ ),  $\text{Per}(0, F) = \text{Per}^\circ(f)$  and  $\text{Per}(F) = \text{Per}^\circ(f) \cup M(0, d) \cup \Lambda(d, \text{Ssh}(s_d))$ .*

A natural strategy to prove the second statement of Conjecture A in the general case (i.e. when no endpoint of the rotation interval is an integer) is to construct examples of maps  $F \in \mathcal{L}_1(S)$  with a *block structure* over maps  $f \in \mathcal{X}_3$  in such a way that  $p/q$  is an endpoint of the rotation interval  $\text{Rot}_{\mathbb{R}}(F)$  and  $\text{Per}(p/q, F) = q \cdot \text{Per}^\circ(f)$ . The next result shows that this is not possible. Hence, if the second statement of Conjecture A holds, the examples must be built by using some more complicated behaviour of the points of the orbit in  $\mathbb{R}$  and on the branches than a block structure.

Let  $F \in \mathcal{L}_1(S)$  and let  $P$  be a periodic orbit (mod 1) of  $F$  with period  $nq$  and rotation number  $p/q$ . For every  $x \in P$  and  $i = 0, 1, \dots, q-1$ , we set

$$P_i(x) := \{F^i(x), G(F^i(x)), G^2(F^i(x)), \dots, G^{n-1}(F^i(x))\},$$

where  $G := F^q - p$ . By Lemma 4.2, every  $P_i(x)$  is a (true) periodic orbit of  $G$  of period  $n$ .

**Theorem D.** Let  $F \in \mathcal{L}_1(S)$  and let  $P$  be a periodic (mod 1) orbit of  $F$  with period  $nq$  and rotation number  $p/q$ . Assume that there exists  $x \in P$  such that  $\langle P_0(x) \rangle$  is homeomorphic to a 3-star and  $\langle P_1(x) \rangle \subset [n, n+1] \subset \mathbb{R}$  for some  $n \in \mathbb{Z}$ . Assume also that  $P_0(x)$  is a periodic orbit of type 3 of  $G := F^q - p$ ,  $F^i(m) \in \langle P_i(x) \rangle$  for  $i = 0, 1, \dots, q-1$  and  $G(m) = m$ , where  $m \in \mathbb{Z} \cap \langle P_0(x) \rangle$  denotes the branching point of  $\langle P_0(x) \rangle$ . Then  $\text{Per}(p/q, F) = q \cdot \mathbb{N}$ .

Next we study the first statement of Conjecture A. It turns out that there are two completely different types of orbits (mod 1) according to the way that they force the existence of other periods. Namely, the periodic (mod 1) orbits contained in  $B$  (viewed at  $\sigma$  level, this means that these periodic orbits do not intersect the circuit of  $\sigma$ ) or the “rotational orbits” that visit the ground  $\mathbb{R}$  of our space  $S$ . We start by studying the periods forced by the periodic (mod 1) orbits contained in  $B$ . We also consider the special case of large orbits (i.e., orbits of large diameter) and show that any orbit of this kind implies periodic (mod 1) points of all periods. To do this, we have to introduce some notation.

**Definition 2.6.** Let  $F \in \mathcal{L}(S)$  and let  $P$  be a periodic (mod 1) orbit of  $F$ . We say that  $P$  lives in the branches when  $P \subset B$ . Observe that, since  $P$  is a (mod 1) orbit, for every  $m \in \mathbb{Z}$ ,  $B_m \cap P = (B_0 \cap P) + m$ .  $\diamond$

The following result holds for any degree. It extends [16, Proposition 5.1] (which deals with  $\sigma$  maps fixing the branching point of  $\sigma$ ) to all  $\sigma$  maps.

**Theorem E.** Let  $F \in \mathcal{L}(S)$  and let  $P$  be a periodic (mod 1) orbit of  $F$  of period  $p$  that lives in the branches. Then  $\text{Per}(F) \supset \text{Ssh}(p)$ . Moreover, for every  $d \in \mathbb{Z}$  and every  $p \in \mathbb{N}_{\text{Sh}}$ , there exists a map  $F_p \in \mathcal{L}_d(S)$  such that  $\text{Per}(F_p) = \text{Ssh}(p)$ .

**Definition 2.7.** Let  $F \in \mathcal{L}(S)$  and let  $Q$  be a (true) periodic orbit of  $F$ . We say that  $Q$  is a large orbit if  $\text{diam}(r(Q)) \geq 1$ , where  $\text{diam}(\cdot)$  denotes the diameter of a set.  $\diamond$

If  $F \in \mathcal{L}(S)$  and if  $Q$  is a true periodic orbit of  $F$ , then  $Q + \mathbb{Z}$  is a periodic (mod 1) orbit of  $F$  of period  $\text{Card}(Q)$ . Clearly,  $Q \subset B$  if and only if  $Q + \mathbb{Z} \subset B$ . Therefore we shall also say that  $Q$  lives in the branches whenever  $Q \subset B$ . Moreover, when  $F$  is of degree 1, true periodic orbits correspond to periodic (mod 1) orbits of rotation number 0. Observe that a periodic orbit  $Q$  living in the branches is large if and only if  $Q$  intersects two different branches.

In the case of large orbits living in the branches and degree 1 maps, we obtain the next result, much stronger than Theorem E

**Theorem F.** Let  $F \in \mathcal{L}_1(S)$  and let  $Q$  be a large orbit of  $F$  such that  $Q$  lives in the branches. Then  $\text{Per}(F) = \mathbb{N}$ .

**Remark 2.8.** Large orbits contained in  $\mathbb{R}$  work as in the circle case by using  $r \circ F$ . More precisely, if  $F \in \mathcal{L}_1(S)$  has a large orbit contained in  $\mathbb{R}$ , then so does the map  $r \circ F$ . Thus, by [9, Theorem 2.2], there exists  $n \in \mathbb{N}$  such that

$$\left[-\frac{1}{n}, \frac{1}{n}\right] \subset \text{Rot}(r \circ F).$$

In the proof of [8, Theorem 4.17], it is shown that, if  $0 \in \text{Int Rot}(r \circ F)$ , then  $F$  has a positive horseshoe and  $\text{Per}(0, F) = \mathbb{N}$ . Consequently,  $\text{Per}(F) \supset \text{Per}(0, F) = \mathbb{N}$ .  $\diamond$

The set of periods of maps from  $\mathcal{L}_1(S)$  having a large orbit that intersects both  $\mathbb{R}$  and the branches remain unknown. Example 6.1 shows that the existence of a large orbit does not ensure that  $\text{Per}(F) = \mathbb{N}$ .

Next we study the orbits forced by the existence of periodic (mod 1) orbits that intersect  $\mathbb{R}$ . We obtain the following theorem, which is the main result of this paper.

**Theorem G.** Let  $F \in \mathcal{L}_1(S)$ . If  $\text{Int}(\text{Rot}_{\mathbb{R}}(F)) \cap \mathbb{Z} \neq \emptyset$ , then  $\text{Per}(F)$  is equal to, either  $\mathbb{N}$ , or  $\mathbb{N} \setminus \{1\}$ , or  $\mathbb{N} \setminus \{2\}$ . Moreover, there exist maps  $F_0, F_1, F_2 \in \mathcal{L}_1(S)$  with  $0 \in \text{Int}(\text{Rot}_{\mathbb{R}}(F_i))$  for  $i = 0, 1, 2$  such that  $\text{Per}(F_0) = \mathbb{N}$ ,  $\text{Per}(F_1) = \mathbb{N} \setminus \{1\}$  and  $\text{Per}(F_2) = \mathbb{N} \setminus \{2\}$ .

The paper is organised as follows. In Section 3, we state some relations about periodic points of different liftings, we recall the notions of covering and positive covering and give some of their properties, which are key tools for finding periodic points. In Section 4, we prove Corollary B and Theorems C and D. In Section 5, we prove Theorems E and F. Section 6, devoted to Theorem G, starts with the construction of examples, then states some more technical lemmas about the set of periods and finally gives the proof of Theorem G. In the last section, we stress some difficulties in the characterisation of the set of periods: a first example shows that, in Theorem G, one cannot replace  $\text{Per}(F)$  by  $\text{Per}(0, F)$  (i.e., periods (mod 1) by true periods), which is an obstacle to apply to  $\sigma$  maps the same method as for circle maps; two other examples show that orderings  $\leq_n$  with  $n > 3$  may be needed to characterise  $\text{Per}(0, F)$ , which might let us think that, in the first statement of Conjecture A, considering orderings  $\leq_2$  and  $\leq_3$  may not be sufficient.

### 3. COVERINGS AND PERIODIC POINTS

**3.1. Relations between periodic points of  $F$  and of  $F + k$ .** Next easy lemma summarises some basic properties of liftings; in particular, periodic (mod 1) points do not depend on the choice of the lifting of a given  $\sigma$ -map.

**Lemma 3.1.** *Let  $F \in \mathcal{L}_d(S)$ . The following statements hold for all  $k, m \in \mathbb{Z}$  and all  $n \geq 0$ :*

- (a)  $F^n(x + m) = F^n(x) + md^n$ ; in particular, if  $d = 1$  then  $F^n(x + m) = F^n(x) + m$ ,
- (b)  $(F + k)^n(x) = F^n(x) + k(1 + d + \dots + d^{n-1})$ ; in particular, if  $d = 1$  then  $(F + k)^n(x) = F^n(x) + kn$  and  $\rho_{F+k}(x) = \rho_F(x) + k$ ,
- (c) If  $F' \in \mathcal{L}_{d'}(S)$ , then  $F' \circ F \in \mathcal{L}_{dd'}(S)$ ,
- (d) A point  $x$  is periodic (mod 1) of period  $n$  for  $F$  if and only if  $x + m$  is periodic (mod 1) of period  $n$  for  $F + k$ . This implies in particular that  $\text{Per}(F) = \text{Per}(F + k)$ ,
- (e) if  $d = 1$  and  $F^n(x) = x + m$ , then  $\rho_F(x) = m/n$ ; thus all periodic (mod 1) points have rational rotation numbers.

*Proof.* Statements (a), (b) and (c) are [8, Lemma 1.6] (see also [8, Lemma 1.10(b)]), and (e) is [8, Remark 1.14(ii)].

We set  $G := F + k$ . By (a) and (b),

$$\forall x \in S, \forall i \in \mathbb{N}, G^i(x + m) = F^i(x) + md^i + k \sum_{j=0}^{i-1} d^j.$$

Therefore  $F^i(x) - x \in \mathbb{Z}$  if and only if  $G^i(x + m) - (x + m) \in \mathbb{Z}$ , which proves (d).  $\square$

The next lemma is implicitly contained in [8, Theorem 3.11]. It is a tool to relate the periods and rotation numbers of periodic (mod 1) orbits with the periods of true orbits of appropriate powers of the map.

**Lemma 3.2.** *Let  $F \in \mathcal{L}_1(S)$ ,  $p \in \mathbb{Z}$  and  $q \in \mathbb{N}$  be such that  $p, q$  are relatively prime. Then  $x$  is a periodic (mod 1) point of  $F$  of period  $mq$  and rotation number  $p/q$  if and only if  $x$  is a (true) periodic point of  $F^q - p$  of period  $m$ .*

*Proof.* Set  $G := F^q - p$ . Assume first that  $x$  is a period (mod 1) point of  $F$  of period  $mq$  and rotation number  $p/q$ . From the definition of periodic (mod 1) point, we have  $F^{mq}(x) = x + k$  for some  $k \in \mathbb{Z}$ . Then  $p/q = \rho_F(x) = k/(mq)$  by Lemma 3.1(e). Hence  $k = mp$ .

By Lemma 3.1(b),  $G^j(x) = F^{qj}(x) - jp$  for every  $j \geq 0$ . Consequently,  $G^m(x) = F^{qm}(x) - mp = x + k - mp = x$  and  $x$  is a true periodic point of  $G$  of period a divisor of  $m$ . Now we have to prove that  $G^j(x) \neq x$  for  $j = 1, 2, \dots, m - 1$ . Assume on the contrary that  $G^d(x) = x$  for some  $d \in \{1, 2, \dots, m - 1\}$ . From above, we have  $x = G^d(x) = F^{qd}(x) - dp$ . Hence  $F^{qd}(x) - x \in \mathbb{Z}$ ; a contradiction with the fact that  $x$  is a periodic (mod 1) point of  $F$  of period  $mq$ . We deduce that  $x$  is of period  $m$  for  $G$ .



Assume now that  $x$  is a (true) periodic point of  $G$  of period  $m$ . From above,  $x = G^m(x) = F^{qm}(x) - mp$ . Thus,  $F^{qm}(x) = x + mp$ ,  $\rho_F(x) = \frac{p}{q}$  and the period (mod 1) of  $x$  for  $F$  is an integer  $d$  that divides  $qm$ . Let  $l \in \mathbb{N}$  and  $a \in \mathbb{Z}$  be such that  $d = \frac{mq}{l}$  and  $F^d(x) = x + a$ . To end the proof, we have to show that  $d = qm$ , that is,  $l = 1$ . Assume on the contrary that  $l > 1$ . Then, by Lemma 3.1(b),

$$x + mp = F^{mq}(x) = F^{ld}(x) = x + la = x + \frac{mq}{d}a.$$

Consequently,  $a = d\frac{p}{q} \in \mathbb{Z}$ . Thus  $d$  must be a multiple of  $q$  because  $p, q$  are coprime. Write  $d = bq$ . Since  $d = \frac{mq}{l}$ , we obtain  $b = \frac{m}{l} < m$ . But, on the other hand,  $F^d(x) = x + a$  can be written as  $F^{bq}(x) = x + bp$ , which is equivalent to  $x = (F^{bq} - bp)(x) = G^b(x)$ . This contradicts the fact that  $x$  is a periodic point of  $G$  of period  $m$ . We deduce that the period (mod 1) of  $x$  for  $F$  is  $mq$ .  $\square$

The following technical lemma will be useful to relate true periodic orbits of maps from  $\mathcal{L}(S)$  wit periodic (mod 1) orbits.

**Lemma 3.3.** *Let  $F \in \mathcal{L}(S)$ ,  $x \in S$  and  $m, k \in \mathbb{Z}$ . Set  $G := F + k$  and  $\tilde{x} := x + m$ .*

- (a) *If  $\tilde{x}$  is a true periodic point of  $G$  of period  $q$ , then  $x$  is a periodic (mod 1) point of  $F$  of period  $q$ . In particular, for  $k = m = 0$ , it states that a true periodic point of  $F$  is also a periodic (mod 1) point of  $F$  of the same period.*
- (b) *If  $x$  is a periodic (mod 1) point of  $F$  of period  $q$  and  $\text{diam}(\text{Orb}(\tilde{x}, G)) < 1$ , then  $\tilde{x}$  is a true periodic point of  $G$  of period  $q$ .*

*Proof.* Let  $d$  denote the degree of  $F$ . Suppose that  $\tilde{x}$  is a periodic point of  $G$  of period  $q$ . Then  $\tilde{x}$  is periodic (mod 1) of period  $p$  for  $G$  with  $p$  a divisor of  $q$ . Let  $n \in \mathbb{Z}$  and  $a \in \mathbb{N}$  be such that  $G^p(\tilde{x}) = \tilde{x} + n$  and  $q = ap$ . According to Lemma 3.1(a,c), the map  $G^p$  is of degree  $d^p$  and

$$G^q(\tilde{x}) = G^{ap}(\tilde{x}) = \tilde{x} + n \sum_{i=0}^{a-1} d^{pi}.$$

This equality is possible only if  $n = 0$ . Thus  $G^p(\tilde{x}) = \tilde{x}$ , which implies that  $p = q$ . Then (a) follows from Lemma 3.1(d).

Let  $x$  be a periodic (mod 1) point of  $F$  of period  $q$ . Then  $\tilde{x} = x + m$  is periodic (mod 1) of period  $q$  for  $G$  by Lemma 3.1(d). If  $\text{diam}(\text{Orb}(\tilde{x}, G)) < 1$ , the fact that  $G^n(\tilde{x}) - \tilde{x} \in \mathbb{Z}$  is equivalent to  $G^n(\tilde{x}) = \tilde{x}$ . This implies that  $\tilde{x}$  is actually a true periodic point of period  $q$  for  $G$ .  $\square$

### 3.2. Coverings and periods.

**Definition 3.4.** Let  $F \in \mathcal{L}(S)$  and let  $I, J$  be compact non-degenerate subintervals of  $S$ . We say that  $I$  *F-covers*  $J$  if there exists a subinterval  $I' \subset I$  such that  $F(I') = J$ . If  $I_1, \dots, I_k$  are compact non-degenerate intervals, the *F-graph* of  $I_1, \dots, I_k$  is the directed graph whose vertices are  $I_1, \dots, I_k$  and there is an arrow from  $I_i$  to  $I_j$  in the graph if and only if  $I_i$  *F-covers*  $I_j$ . Then we write  $I_i \longrightarrow I_j$  (or  $I_i \xrightarrow{F} I_j$  if the map needs to be specified) to mean that  $I_i$  *F-covers*  $I_j$ .

A *path of coverings of length  $n$*  is a sequence

$$J_0 \xrightarrow{F_0} J_1 \xrightarrow{F_1} \cdots \xrightarrow{F_{n-1}} J_n,$$

where  $J_0, \dots, J_n$  are compact non-degenerate intervals and  $F_i: J_i \longrightarrow S$  are continuous maps (generally of the form  $F^{n_i} - p_i$ ) for all  $0 \leq i \leq n-1$ . Such a path is called a *loop* if  $J_n = J_0$ . If all the maps  $F_i$  are equal to  $F$  and  $J_0, \dots, J_n \in \{I_1, \dots, I_k\}$ , we speak about paths (resp. loops) in the *F-graph* of  $I_1, \dots, I_k$ .

Consider two paths of the form

$$\begin{aligned}\mathcal{A} &= J_0 \xrightarrow{F_0} J_1 \xrightarrow{F_1} \cdots \xrightarrow{F_{n-1}} J_n, \\ \mathcal{B} &= J_n \xrightarrow{F_n} J_{n+1} \xrightarrow{F_{n+1}} \cdots \xrightarrow{F_{n+m-1}} J_{n+m}.\end{aligned}$$

Then  $\mathcal{AB}$  will denote the concatenation of these two paths, that is,

$$\mathcal{AB} = J_0 \xrightarrow{F_0} J_1 \xrightarrow{F_1} \cdots \xrightarrow{F_{n-1}} J_n \xrightarrow{F_n} \cdots \xrightarrow{F_{n+m-1}} J_{n+m}.$$

If  $J_n = J_0$ , it is possible to concatenate  $\mathcal{A}$  with itself and, for every  $n \in \mathbb{N}$ ,  $\mathcal{A}^n$  will denote the concatenation of  $\mathcal{A}$  with itself  $n$  times.  $\diamond$

When considering an  $F$ -graph, the intervals are often defined from a finite collection of points.

**Definition 3.5.** Let  $P$  be a finite subset of  $S$ . A  $P$ -basic interval is any set  $\langle a, b \rangle$ , where  $a, b$  are two distinct points in  $P$  such that  $\langle a, b \rangle \cap \langle P \rangle = \{a, b\}$ . Observe that, if  $P$  contains all the branching points  $\mathbb{Z} \cap \langle P \rangle$ , then the  $P$ -basic intervals are equal to the closure of the connected components of  $\langle P \rangle \setminus P$ .  $\diamond$

**Remark 3.6.** If  $\text{Int}(I)$  and  $\text{Int}(J)$  contain no branching point, the fact that  $F(I) \supset J$  implies  $I \rightarrow J$ . In what follows, we shall only use coverings with intervals containing no branching point in their interior.  $\diamond$

The next result is the key property for finding periodic points with coverings. It is [7, Lemma 1.2.7] generalised to intervals in  $S$ .

**Proposition 3.7.** Let  $I_0, I_1, \dots, I_n$  be compact subintervals of  $S$  with  $I_n = I_0$  and, for every  $0 \leq i \leq n-1$ , let  $F_i: I_i \rightarrow S$  be a continuous map such that  $I_i$   $F_i$ -covers  $I_{i+1}$ . Then there exist points  $x_i \in I_i$ ,  $i = 0, \dots, n$ , such that  $F_i(x_i) = x_{i+1}$  for all  $0 \leq i \leq n-1$  and  $x_n = x_0$ . In particular,

- if  $F_i = F$  for all  $0 \leq i \leq n-1$  (in other words,  $I_0 \rightarrow I_1 \rightarrow \cdots \rightarrow I_{n-1} \rightarrow I_0$  is a loop in the  $F$ -graph of  $I_1, \dots, I_{n-1}$ ), then  $F^n(x_0) = x_0$ ;
- if  $F_i = F + k_i$  with  $k_i \in \mathbb{Z}$  for all  $0 \leq i \leq n-1$ , then  $F^n(x_0) \in x_0 + \mathbb{Z}$ .

The next lemma shows that, under certain hypotheses (that is, in presence of “semi horse-shoes”), we have periodic points of all periods. It is a generalisation of [7, Proposition 1.2.9] and its proof is a variant of the proof of that result. However, we include it for clarity.

**Proposition 3.8.** Let  $F \in \mathcal{L}(S)$  and assume that there exist two compact non-degenerate subintervals  $K$  and  $L$  of  $S$  such that  $K$  and  $L$  do not contain branching points in their interior,  $\text{Int}(K) \cap \text{Int}(L) = \emptyset$  and  $F(K) \supset L$  and  $F(L) \supset K \cup L$ . Then, for every  $n \in \mathbb{N}$ , the map  $F$  has a periodic orbit of period  $n$  contained in  $K \cup L$ .

*Proof.* By assumption,  $K \rightarrow L$  and  $L \rightarrow K, L$ . Since  $K, L$  contain no branching point in their interior, the set  $J := \langle K \cup L \rangle$  is an interval (which may contain branching points). By continuity of  $F$ , there exist subintervals  $L' \subset L$  and  $K' \subset K$  such that  $F(L') \supset J$ ,  $F(\text{Bd}(L')) = \text{Bd}(J)$ ,  $F(K') = L'$  and  $F(\text{Bd}(K')) = \text{Bd}(L')$ . Therefore, for every  $n \in \mathbb{N}$ , there is a loop

$$K' \rightarrow L' \rightarrow L' \rightarrow \cdots \rightarrow L' \rightarrow K'$$

of length  $n$  in the  $F$ -graph of  $K', L'$  (if  $n = 1$ , the loop we take is  $L' \rightarrow L'$ ). By Proposition 3.7,  $F$  has a periodic point  $x \in K'$  such that  $F^i(x) \in L'$  for  $i = 1, 2, \dots, n-1$  and  $F^n(x) = x$  (if  $n = 1$ ,  $F(x) = x \in L'$ ). To prove that  $x$  has period  $n$ , we have to show that  $F^i(x) \neq x$  for all  $i = 1, 2, \dots, n-1$ .

Suppose now that  $F^i(x) = x$  for some  $i \in \{1, 2, \dots, n-1\}$  (in particular  $n > 1$ ). Then  $x = F^i(x)$  belongs to  $K' \cap L'$ , and hence

$$(3.1) \quad x \in \text{Bd}(L').$$

Consequently,  $F(x) = F^{i+1}(x) \in \text{Bd}(J)$ . If  $i+1 \leq n-1$ , then  $F(x) = F^{i+1}(x)$  also belongs to  $L'$  and, hence, it is the unique point in  $\text{Bd}(L') \cap \text{Bd}(J)$  and, again,  $F^2(x) = F^{i+2}(x) \in \text{Bd}(J)$ .

Iterating this argument, we see that  $F^l(x) = F^{i+l}(x) \in \text{Bd}(J)$  for all  $l = 0, 1, \dots, n - i$ . Then  $x = F^n(x) = F^{n-i}(x) \in K' \cap \text{Bd}(J)$ , which implies that  $x$  is the endpoint of  $J$  that does not belong to  $L'$ . But this contradicts (3.1). We conclude that the period of  $x$  is equal to  $n$ .  $\square$

The next lemma is similar to the previous one, except that the coverings are (mod 1).

**Lemma 3.9.** *Let  $F \in \mathcal{L}_1(S)$ . Let  $I, J$  be two non empty compact intervals in  $S$  such that  $\text{Int}(I), \text{Int}(J)$  are disjoint and contain no branching point. Suppose that there exist  $k_1, k_2, k_3 \in \mathbb{Z}$  such that*

$$I \xrightarrow{F-k_1} I, \quad I \xrightarrow{F-k_2} J, \quad J \xrightarrow{F-k_3} I.$$

Suppose in addition that

- either  $I, J$  are disjoint (mod 1) (that is,  $(I + \mathbb{Z}) \cap (J + \mathbb{Z}) = \emptyset$ ),
- or  $k_3 = k_1$ .

Then  $\text{Per}(F) = \mathbb{N}$ .

*Proof.* We fix  $n \in \mathbb{N}$ . For  $n = 1$ , we consider the loop  $I \xrightarrow{F-k_1} I$ , and there exists a fixed (mod 1) point in  $I$  by Proposition 3.7. For  $n \geq 2$ , we consider the loop of length  $n$

$$J \xrightarrow{F-k_3} I \xrightarrow{F-k_1} I \xrightarrow{F-k_1} \cdots \xrightarrow{F-k_1} I \xrightarrow{F-k_2} J.$$

By Proposition 3.7,  $F$  has a periodic (mod 1) point  $x \in J$  such that  $F^n(x) = x + k_3 + (n-2)k_1 + k_2$  and  $F^i(x) \in I + k_3 + (i-1)k_1$  for all  $1 \leq i \leq n-1$ . Let  $d$  denote the period (mod 1) of  $x$ .

If  $I, J$  are disjoint (mod 1), then  $F^i(x) - x \notin \mathbb{Z}$  for all  $1 \leq i \leq n-1$ , and thus  $d = n$ .

Suppose now that  $k_3 = k_1 \neq k_2$ . Then

$$\rho_F(x) = \frac{k_3 + (n-2)k_1 + k_2}{n} = k_1 + \frac{k_2 - k_1}{n}.$$

If  $d < n$ , then  $F^d(x) = x + k_3 + (d-1)k_1$  and hence

$$\rho_F(x) = \frac{k_3 + (d-1)k_1}{d} = k_1.$$

But this is impossible because  $\frac{k_2 - k_1}{n} \neq 0$ . We deduce that, if  $k_3 = k_1 \neq k_2$ , then  $d = n$ .

Finally, if  $k_1 = k_2 = k_3$ , then Proposition 3.8 applies to the map  $G := F - k_1$  and  $\text{Per}(G) = \mathbb{N}$ . Thus  $\text{Per}(F) = \mathbb{N}$  by Lemma 3.1(d). This concludes the proof.  $\square$

**3.3. Positive coverings.** The notion of positive covering for subintervals of  $\mathbb{R}$  was introduced in [8]. It can be extended to all subintervals on which a retraction can be defined. This is in particular the case of all intervals which have an infinite tree as the ambient space.

If  $I \subset S$  is an interval, it can be endowed with two opposite linear orders; we denote them by  $<_I$  and  $>_I$ . When  $I \subset \mathbb{R}$ , we choose  $<_I$  so that it coincide with the order  $<$  in  $\mathbb{R}$ ; when  $I \subset B$ , we choose  $<_I$  so that  $x <_I y \Leftrightarrow \text{Im}(x) < \text{Im}(y)$ . In the other cases,  $<_I$  is chosen arbitrarily. The notations  $\leq_I$  and  $\geq_I$  are defined consistently.

**Definition 3.10.** Let  $F \in \mathcal{L}(S)$  and let  $I, J$  be compact non-degenerate subintervals of  $S$ , endowed with orders  $<_I, <_J$ . We say that  $(I, <_I)$  *positively* (resp. *negatively*)  $F$ -covers  $(J, <_J)$  and we write  $(I, <_I) \xrightarrow{F}^+ (J, <_J)$  (resp.  $(I, <_I) \xrightarrow{F}^- (J, <_J)$ ) if there exist  $x, y \in I$  such that  $x \leq_I y$ ,  $F(x) = \min J$  and  $F(y) = \max J$  (resp.  $F(x) = \max J$  and  $F(y) = \min J$ ). When there is no ambiguity on the orders (or no need to precise them), we simply write  $I \xrightarrow{F}^+ J$  or  $I \xrightarrow{F}^- J$ .  $\diamond$

We remark that the notion of positive or negative covering does not imply (unlike the usual notion of  $F$ -covering) that there exists a closed subinterval of  $I' \subset I$  such that  $F(I') = J$ . However, it does for the retracted map.

We recall that the retraction  $r_I: S \rightarrow I$  is defined as follows:

$$r_I(x) = \begin{cases} x & \text{if } x \in I \\ c_x & \text{if } x \notin I, \end{cases}$$

where  $c_x$  is the only point in  $I$  such that  $\langle c_x, x \rangle \cap I = \{c_x\}$  (it exists since  $S$  is uniquely arcwise connected).

**Remark 3.11.**  $(I, <_I)$  positively (resp. negatively)  $F$ -covers  $(J, <_J)$  if and only if there exist  $x, y \in I$ ,  $x \leq_I y$ , such that  $r_J \circ F(x) = \min J$  and  $r_J \circ F(y) = \max J$  (resp.  $r_J \circ F(x) = \max J$  and  $r_J \circ F(y) = \min J$ ). Moreover, if  $I$  positively or negatively  $F$ -covers  $J$ , then there exists a closed subinterval  $I' \subset I$  such that  $r_J(F(I')) = J$  and  $F(\text{Bd}(I')) = \text{Bd}(J)$ .  $\diamond$

If  $\varepsilon, \varepsilon' \in \{+, -\}$ , the product  $\varepsilon\varepsilon' \in \{+, -\}$  denotes the usual product of signs, and  $-\varepsilon$  denotes the opposite sign.

**Definition 3.12.** A loop of signed coverings of length  $k$  is a sequence

$$(I_0, <_0) \xrightarrow{F_1} (I_1, <_1) \xrightarrow{F_2} \cdots (I_{k-1}, <_{k-1}) \xrightarrow{F_k} (I_0, <_0),$$

where  $(I_0, <_0), (I_1, <_1), \dots, (I_{k-1}, <_{k-1})$  are compact non-degenerate intervals of  $S$  endowed with an order,  $\varepsilon_i \in \{+, -\}$  and  $F_i: I_i \rightarrow S$  are continuous maps (usually of the form  $F^{n_i} - p_i$ ) for all  $1 \leq i \leq k$ . The *sign* of the loop is defined to be the product  $\varepsilon_1\varepsilon_2 \cdots \varepsilon_k$ . The loop is said *positive* (resp. *negative*) depending on its sign. We shall use the same notations for concatenations of paths of signed coverings as for coverings. It is clear that the sign of the concatenation is the product of the signs of the paths involved.  $\diamond$

The next lemma studies the dependence of the sign of a loop of signed coverings on the chosen orderings.

**Lemma 3.13.** *Let*

$$(I_0, <_0) \xrightarrow{F_1} (I_1, <_1) \xrightarrow{F_2} \cdots (I_{k-1}, <_{k-1}) \xrightarrow{F_k} (I_0, <_0),$$

be a loop of signed coverings of sign  $\varepsilon$ .

(a) For every  $0 \leq i \leq k-1$ , let  $\widetilde{<}_i \in \{<_i, >_i\}$ . Then, there exist  $\varepsilon'_1, \dots, \varepsilon'_k \in \{+, -\}$  such that

$$(I_0, \widetilde{<}_0) \xrightarrow{F_1} (I_1, \widetilde{<}_1) \xrightarrow{F_2} \cdots (I_{k-1}, \widetilde{<}_{k-1}) \xrightarrow{F_k} (I_0, \widetilde{<}_0),$$

and the sign of this loop is equal to  $\varepsilon$ . Consequently, the sign of a loop is independent of the orders.

(b) For every  $1 \leq i \leq k-1$ , there exists  $\widetilde{<}_i \in \{<_i, >_i\}$  such that

$$(I_0, <_0) \xrightarrow{F_1} (I_1, \widetilde{<}_1) \xrightarrow{F_2} \cdots \xrightarrow{F_{k-1}} (I_{k-1}, \widetilde{<}_{k-1}) \xrightarrow{F_k} (I_0, <_0).$$

*Proof.* Consider a sequence of two signed coverings  $(I, <_I) \xrightarrow{F} (J, <_J) \xrightarrow{G} (K, <_K)$ . If we reverse the order on  $J$ , it is clear from the definition that we reverse the signs of both coverings. That is,

$$(3.2) \quad (I, <_I) \xrightarrow{-F} (J, >_J) \xrightarrow{-G} (K, <_K).$$

To prove (a), it is sufficient to show that reversing any order gives a new loop of signed coverings with the same sign. If  $1 \leq i \leq k-1$ , according to (3.2), changing  $<_i$  into  $>_i$  changes  $\varepsilon_{i-1}$  and  $\varepsilon_i$  into  $-\varepsilon_{i-1}$  and  $-\varepsilon_i$  respectively. Changing  $<_0$  into  $>_0$  changes  $\varepsilon_1$  and  $\varepsilon_k$  into  $-\varepsilon_1$  and  $-\varepsilon_k$  respectively. In both cases, we obtain a new loop of signed coverings with the same sign.

To prove (b), we define inductively  $\widetilde{<}_i$  for  $i = 1, \dots, k-1$ .

Let  $i \in \{1, \dots, k-1\}$  and suppose that  $\widetilde{<}_1, \dots, \widetilde{<}_{i-1}$  have already been chosen such that

$$(I_0, <_0) \xrightarrow{F_1^+} (I_1, \widetilde{<}_1) \xrightarrow{F_2^+} \dots \xrightarrow{F_{i-1}^+} (I_{i-1}, \widetilde{<}_{i-1}) \xrightarrow{F_i^{\varepsilon'_i}} (I_i, <_i) \xrightarrow{F_{i+1}^{\varepsilon'_{i+1}}} \dots \xrightarrow{F_k^{\varepsilon'_k}} (I_0, <_0),$$

for some  $\varepsilon'_i, \dots, \varepsilon'_k \in \{+, -\}$ . If  $\varepsilon'_i = +$ , let  $\widetilde{<}_i$  be equal to  $<_i$  and  $\varepsilon''_{i+1} := \varepsilon'_{i+1}$ . Otherwise, let  $\widetilde{<}_i$  be equal to  $>_i$  and  $\varepsilon''_{i+1} := -\varepsilon'_{i+1}$ . According to (3.2), we obtain

$$(I_0, <_0) \xrightarrow{F_1^+} \dots \xrightarrow{F_{i-1}^+} (I_{i-1}, \widetilde{<}_{i-1}) \xrightarrow{F_i^+} (I_i, \widetilde{<}_i) \xrightarrow{F_{i+1}^{\varepsilon''_{i+1}}} (I_i, <_{i+1}) \xrightarrow{F_{i+2}^{\varepsilon'_{i+2}}} \dots \xrightarrow{F_k^{\varepsilon'_k}} (I_0, <_0).$$

Then, when all orderings  $\widetilde{<}_1, \dots, \widetilde{<}_{k-1}$  are defined, we obtain

$$(I_0, <_0) \xrightarrow{F_1^+} (I_1, \widetilde{<}_1) \xrightarrow{F_2^+} \dots \xrightarrow{F_{k-1}^+} (I_{k-1}, \widetilde{<}_{k-1}) \xrightarrow{F_k^{\varepsilon'}} (I_0, <_0)$$

for some  $\varepsilon' \in \{+, -\}$ . The sign of this loop is  $\varepsilon'$ , which is equal to  $\varepsilon$  according to (a).  $\square$

The next result is the analogous of Proposition 3.7 for signed coverings.

**Proposition 3.14.** *Let  $F \in \mathcal{L}_1(S)$  and let  $(I_0, <_0), (I_1, <_1), \dots, (I_{k-1}, <_{k-1})$  be compact non degenerate intervals of  $S$  endowed with an order such that*

$$(I_0, <_0) \xrightarrow{F_1^{\varepsilon_1}} (I_1, <_1) \xrightarrow{F_2^{\varepsilon_2}} \dots \xrightarrow{F_{k-1}^{\varepsilon_{k-1}}} (I_{k-1}, <_{k-1}) \xrightarrow{F_k^{\varepsilon_k}} (I_0, <_0)$$

is a positive loop of signed coverings, where  $n_i \in \mathbb{N}$  and  $p_i \in \mathbb{Z}$ . For every  $i \in \{1, 2, \dots, k\}$ , set  $m_i := \sum_{j=1}^i n_j$  and  $\widehat{p}_i := \sum_{j=1}^i p_j$ . Then there exists  $x_0 \in I_0$  such that  $F^{m_k}(x_0) = x_0 + \widehat{p}_k$  and  $F^{m_i}(x_0) \in I_i + \widehat{p}_i$  for all  $1 \leq i \leq k-1$ .

*Proof.* According to Lemma 3.13, for every  $1 \leq i \leq k-1$ , there exists  $\widetilde{<}_i \in \{<_i, >_i\}$  such that

$$(I_0, <_0) \xrightarrow{F_1^+} (I_1, \widetilde{<}_1) \xrightarrow{F_2^+} \dots \xrightarrow{F_{k-1}^+} (I_{k-1}, \widetilde{<}_{k-1}) \xrightarrow{F_k^+} (I_0, <_0).$$

Thus we can consider a loop in which all coverings are positive. In this case, we have the same situation as [8, Proposition 2.3] except that [8, Proposition 2.3] is stated for subintervals of  $\mathbb{R}$ . Actually this assumption plays no role (except simplifying the notations), and the proof in our context works exactly the same by using the map  $F$  composed with appropriate retractions.  $\square$

The next result is analogous to Lemma 3.9 (indeed to a particular case of Lemma 3.9) with the semi horseshoe being made of positive coverings.

**Corollary 3.15.** *Let  $F \in \mathcal{L}_1(S)$  and let  $I \subset S$  be a compact interval such that  $(I+n)_{n \in \mathbb{Z}}$  are pairwise disjoint. If  $I \xrightarrow{F^+} I$  and  $I \xrightarrow{F^+} I+k$  for some  $k \in \mathbb{Z} \setminus \{0\}$ , then  $\text{Per}(F) = \mathbb{N}$ .*

*Proof.* Fix  $n \in \mathbb{N}$ . We consider the following loop of positive coverings of length  $n$ :

$$I \xrightarrow{F^+} I \xrightarrow{F^+} I \dots \xrightarrow{F^+} I \xrightarrow{F^+} I+k.$$

By Proposition 3.14, there exists a point  $x \in I$  such that  $F^n(x) = x+k$  and  $F^i(x) \in I$  for all  $1 \leq i \leq n-1$ . In particular,  $\rho_F(x) = k/n \neq 0$ . Suppose that  $F^i(x) \in x + \mathbb{Z}$  for some  $i \in \{1, 2, \dots, n-1\}$ . Both  $x$  and  $F^i(x)$  belong to  $I$ , and thus  $F^i(x) = x$  because  $(I+n)_{n \in \mathbb{Z}}$  are pairwise disjoint. But this implies that  $\rho_F(x) = 0$ , which is a contradiction. Therefore the period (mod 1) of  $x$  is equal to  $n$ . Finally,  $\text{Per}(F) = \mathbb{N}$ .  $\square$

The next lemma is a technical result in the spirit of the previous one. It shows that, when certain signed loops are available, the set of periods contains  $\mathbb{N} \setminus \{2\}$ .

**Lemma 3.16.** *Let  $F \in \mathcal{L}_1(S)$ . Let  $K, L \subset S$  be two compact intervals in  $S$  and let  $e \in S$  be such that  $(K + \mathbb{Z}) \cap (L + \mathbb{Z}) \subset \{e\} + \mathbb{Z}$  and  $F(e) \notin L + \mathbb{Z}$ . Suppose that there exist  $k_1, k_2, k_3, k_4 \in \mathbb{Z}$  such that*

$$L \xrightarrow{F-k_1^+} L, \quad L \xrightarrow{F-k_2^+} K, \quad K \xrightarrow{F-k_3^-} L, \quad K \xrightarrow{F-k_4^-} K.$$

Then  $\text{Per}(F) \supset \mathbb{N} \setminus \{2\}$ .

*Proof.* According to Proposition 3.14 applied to the loop  $L \xrightarrow[F-k_1]{+} L$ , there exists a fixed point (mod 1) of  $F$  in  $L$ . Hence  $1 \in \text{Per}(F)$ .

We now fix  $n \geq 3$  and we consider the following positive loop of length  $n$ :

$$(L \xrightarrow[F-k_2]{+} K \xrightarrow[F-k_4]{-} K \xrightarrow[F-k_3]{-} L)(L \xrightarrow[F-k_1]{+} L)^{n-3}.$$

By Proposition 3.14, there exists a point  $x \in L$  such that  $F(x) \in K + \mathbb{Z}$ ,  $F^2(x) \in K + \mathbb{Z}$ ,  $F^i(x) \in L + \mathbb{Z}$  for all  $3 \leq i \leq n$  and  $F^n(x) - x \in \mathbb{Z}$ . Thus  $x$  is a periodic (mod 1) point for  $F$  and its period  $p$  divides  $n$ . It remains to prove that the period (mod 1) of  $x$  is exactly  $n$ . Suppose on the contrary that  $p < n$ . Then  $1 \leq p \leq n - 2$  because  $p$  divides  $n \geq 3$ . Thus  $F^2(x) \in K + \mathbb{Z}$ ,  $F^{2+p}(x) \in L + \mathbb{Z}$  and  $F^{2+p}(x) - F^2(x) \in \mathbb{Z}$ . By assumption, this is possible only if  $F^2(x) \in e + \mathbb{Z}$ . This leads to a contradiction because  $F^3(x) \in L + \mathbb{Z}$  whereas  $F(e) \notin L + \mathbb{Z}$ . This proves that  $p = n$ , and hence,  $\forall n \geq 3$ ,  $n \in \text{Per}(F)$ . Consequently,  $\text{Per}(F) \supset \mathbb{N} \setminus \{2\}$ .  $\square$

#### 4. SETS OF PERIODS OF 3-STAR AND DEGREE 1 CIRCLE MAPS OCCUR FOR DEGREE 1 $\sigma$ -MAPS

Misiurewicz's Theorem 2.5 gives a characterisation of the sets of periods of circle maps of degree 1. It is very easy to build a map in  $\mathcal{L}_1(S)$  whose set of periods (mod 1) is equal to the set of periods of a given degree 1 circle maps. This leads to the following result (see Section 2 for the notations).

**Corollary B.** *Given  $c, d \in \mathbb{R}$  with  $c \leq d$  and  $s_c, s_d \in \mathbb{N}_{\text{Sh}}$ , there exists a map  $F \in \mathcal{L}_1(S)$  such that  $\text{Rot}_{\mathbb{R}}(F) = [c, d]$  and  $\text{Per}(F) = \Lambda(c, \text{Ssh}(s_c)) \cup M(c, d) \cup \Lambda(d, \text{Ssh}(s_d))$ .*

*Proof.* By Theorem 2.5, there exists a map  $\tilde{F} \in \mathcal{L}_1(\mathbb{R})$  such that  $\text{Rot}(\tilde{F}) = [c, d]$  and  $\text{Per}(\tilde{F}) = \Lambda(c, \text{Ssh}(s_c)) \cup M(c, d) \cup \Lambda(d, \text{Ssh}(s_d))$ . Then we define  $F \in \mathcal{L}_1(S)$  by

$$F(x) = \begin{cases} \tilde{F}(x) & \text{if } x \in \mathbb{R}, \\ \tilde{F}(m) & \text{if } x \in B_m. \end{cases}$$

Clearly,  $F$  is continuous,  $\text{Rot}(F) = \text{Rot}_{\mathbb{R}}(F) = \text{Rot}(\tilde{F})$  and every periodic (mod 1) point of  $F$  is contained in  $\mathbb{R}$ . Hence,  $\text{Per}(F) = \text{Per}(\tilde{F})$ . This ends the proof of the corollary.  $\square$

It is also easy to build a map in  $\mathcal{L}_1(S)$  whose set of periods is equal to the set of periods of a given 3-star map. This construction can be done in such a way that the rotation interval is any interval of the form  $[0, d]$  or  $[d, 0]$ . The set of periods (mod 1) is then a combination of a set of periods of a 3-star map and a set of periods of a degree 1 circle map, as stated in the next result.

**Theorem C.** *Let  $d \neq 0$  be a real number,  $s_d \in \mathbb{N}_{\text{Sh}}$  and  $f \in \mathcal{X}_3$ . Then there exists a map  $F \in \mathcal{L}_1(S)$  such that  $\text{Rot}_{\mathbb{R}}(F) = \text{Rot}(F)$  is the closed interval with endpoints 0 and  $d$  (i.e.,  $[c, d]$  or  $[d, c]$ ),  $\text{Per}(0, F) = \text{Per}^\circ(f)$  and  $\text{Per}(F) = \text{Per}^\circ(f) \cup M(0, d) \cup \Lambda(d, \text{Ssh}(s_d))$ .*

*Proof.* We shall only consider the case  $d > 0$ . The case  $d$  negative is analogous.

From Theorem 2.5, it follows that there exists a map  $G \in \mathcal{L}_1(\mathbb{R})$  such that  $\text{Rot}(G) = [0, d]$  and  $\text{Per}(G) = \{1\} \cup M(c, d) \cup \Lambda(d, \text{Ssh}(s_d))$ . Moreover, from the proof of Theorem 2.5 (see [7, Theorem 3.10.1]), the map  $G$  is constructed in such a way that  $G(0) = 0$ , there exist  $u \leq 1/2 \leq v$  such that  $G|_{[0, u]}$  and  $G|_{[v, 1]}$  are affine and  $\rho_G(x) = d$  for every  $x \in [u, v]$ , and  $\rho_G(x) \neq 0$  for every  $x \in \mathbb{R} \setminus \bigcup_{n \geq 0} G^{-n}(\mathbb{Z})$ .

To prove the theorem, we shall construct a map  $F \in \mathcal{L}_1(S)$  such that  $\text{Rot}_{\mathbb{R}}(F) = \text{Rot}(F) = \text{Rot}(G) = [0, d]$ ,  $\text{Per}(0, F) = \text{Per}^\circ(f)$  and  $\text{Per}(F) = \text{Per}(0, F) \cup \text{Per}(G)$ .

Let  $0 < b < a < 1/2$ . For every  $m \in \mathbb{Z}$ , let  $Y_m^a$  (resp.  $Y_m^b$ ) denote the set  $[m - a, m + a] \cup B_m$  (resp.  $[m - b, m + b] \cup B_m$ ). Observe that  $Y_m^a \cap Y_j^a = \emptyset$  whenever  $m \neq j$ ,  $Y_m^b \subset Y_m^a$ , and the set  $Y_m^a \setminus Y_m^b$  has two connected components:  $[m - a, m - b)$  and  $(m + b, m + a]$ . Moreover, the sets  $Y_m^a$  and  $Y_m^b$  are homeomorphic to  $X_3$ . Let  $\beta_0$  denote a homeomorphism from  $Y_0^b$  to  $X_3$ .

Set  $Z := \bigcup_{i=0}^{\infty} G^{-i}(\mathbb{Z})$ . Since  $G(m) = m$  for every  $m \in \mathbb{Z}$ , both sets  $Z$  and  $\mathbb{R} \setminus Z$  are  $G$ -invariant and  $\mathbb{Z} \subset Z$ . Moreover,  $\rho_G(x) = 0$  for all  $x \in Z$ . Thus,  $Z \cap (G([u, v]) + \mathbb{Z}) = \emptyset$  and

$$(4.1) \quad Z \subset ([0, u] \cup (v, 1]) + \mathbb{Z}$$

because  $d \neq 0$ . Since  $G|_{[0, u]}$  and  $G|_{(v, 1]}$  are affine, this implies that every point in  $Z$  has finitely many preimages and, hence,  $Z$  is countable. Moreover, since  $G$  has degree one (Lemma 3.1(a)),  $Z + \mathbb{Z} = Z$ . Therefore, there exists a continuous map  $\varphi: S \rightarrow \mathbb{R}$  such that  $\varphi(x+1) = \varphi(x) + 1$  for all  $x \in S$ ,  $\varphi^{-1}(m) = Y_m^a$  for every  $m \in \mathbb{Z}$ ,  $\varphi|_{\mathbb{R}}$  is non-decreasing,  $\varphi^{-1}(x)$  is a point for every  $x \notin Z$  and  $\varphi^{-1}(x)$  is a non-degenerate interval for every  $x \in Z \setminus \mathbb{Z}$ . The idea is similar to Denjoy's construction: under the action of  $\varphi^{-1}$ , every integer  $m$  is blown up into the 3-star  $Y_m^a$ , then the preimages of  $m$  under  $G$  are blown up too, in order to be able to define a map  $F: S \rightarrow S$  which is a semiconjugacy of  $G$ .

Now we define our map  $F$  as follows:

**$F|_{\mathbf{Y}_m^a}$ :** we set  $F|_{Y_0^b} = \beta_0^{-1} \circ f \circ \beta_0$ ,  $F(a) = a$ ,  $F(-a) = -a$  and we define  $F|_{[-a, -b]}$  and  $F|_{[b, a]}$  affinely in such a way that  $F|_{Y_0^a}$  is continuous. Then, for every  $m \in \mathbb{Z}$  and  $x \in Y_m^a$ , we set  $F(x) := F(x - m) + m$ . In particular,  $F(Y_m^a) \subset Y_m^a$  for every  $m \in \mathbb{Z}$ .

**$F|_{\varphi^{-1}(Z \setminus G^{-1}(\mathbb{Z}))}$ :** For every  $y \in Z \setminus G^{-1}(\mathbb{Z})$ , the sets  $\varphi^{-1}(y)$  and  $\varphi^{-1}(G(y))$  are intervals because  $y$  and  $G(y)$  belong to  $Z \setminus \mathbb{Z}$ . Moreover, by (4.1), the map  $G$  is, either increasing, or decreasing at  $y$ . We define  $F|_{\varphi^{-1}(y)}$  to be the unique affine map from  $\varphi^{-1}(y)$  onto  $\varphi^{-1}(G(y))$  which is increasing (respectively decreasing) when  $G$  is increasing (respectively decreasing) at  $y$ . In particular  $F(\text{Bd}(\varphi^{-1}(y))) = \text{Bd}(\varphi^{-1}(G(y)))$ .

**$F|_{\varphi^{-1}(G^{-1}(\mathbb{Z}) \setminus \mathbb{Z})}$ :** For every  $y \in G^{-1}(\mathbb{Z}) \setminus \mathbb{Z}$ , it follows that  $y \in Z \setminus \mathbb{Z}$  and  $G(y) \in \mathbb{Z}$ . We define  $F|_{\varphi^{-1}(y)}$  to be the unique affine map from  $\varphi^{-1}(y)$  onto  $[G(y) - a, G(y) + a]$  which is increasing (respectively decreasing) when  $G$  is increasing (respectively decreasing) at  $y$ . In this case we have  $F(\text{Bd}(\varphi^{-1}(y))) = \{G(y) - a, G(y) + a\}$ .

**$F|_{\varphi^{-1}(\mathbb{R} \setminus Z)}$ :** For every  $y \in \mathbb{R} \setminus Z$ ,  $G(y) \notin Z$  and  $\varphi^{-1}(y)$  and  $\varphi^{-1}(G(y))$  are single points. We set  $F(\varphi^{-1}(y)) = \varphi^{-1}(G(y))$ .

Observe that, by definition,  $F$  is continuous in every connected component of  $\varphi^{-1}(Z)$ . To see that  $F$  is globally continuous, notice that, for every  $y \in Z$ ,  $F(z)$  has one-sided limits as  $z \in \varphi^{-1}(\mathbb{R} \setminus Z)$  tends to the endpoints of  $\varphi^{-1}(y)$ , and these limits are equal to the endpoints of  $\varphi^{-1}(G(y))$ . Consequently,  $F$  is continuous. Moreover, from the definition of  $F$  and the fact that  $\varphi(x+1) = \varphi(x) + 1$ ,  $F$  has degree 1. Hence,  $F \in \mathcal{L}_1(S)$ . Furthermore, the fact that  $F(Y_m^a) \subset Y_m^a$  implies that  $\forall m \in \mathbb{Z}, \forall x \in Y_m^a, \rho_F(x) = \rho_F(m) = 0$ , and hence  $\text{Rot}(F) = \text{Rot}_{\mathbb{R}}(F)$ .

On the other hand, from the definition of  $F$ , it follows that  $F$  is semiconjugate with  $G$  through  $\varphi$ , that is,  $G \circ \varphi = \varphi \circ F$ . Hence,

$$(4.2) \quad G^n \circ \varphi = \varphi \circ F^n \quad \text{for every } n \in \mathbb{N}.$$

From (4.2), it follows that  $\rho_F(x) = \rho_G(\varphi(x))$  for all  $x \in S$ . Consequently,  $\text{Rot}(F) = \text{Rot}_{\mathbb{R}}(F) = \text{Rot}(G) = [0, d]$  and

$$(4.3) \quad \rho_F(x) = 0 \quad \text{if and only if} \quad \exists i \geq 0, m \in \mathbb{Z} \text{ such that } F^i(x) \in Y_m^a,$$

i.e.,  $F^i(x - m) \in Y_0^a$ . Thus,  $\text{Per}(0, F) = \text{Per}^\circ(F|_{Y_0^a})$ .

Now we are going to prove that  $\text{Per}^\circ(F|_{Y_0^a}) = \text{Per}^\circ(f)$ , which implies  $\text{Per}(0, F) = \text{Per}^\circ(f)$ . By definition,  $\text{Per}^\circ(F|_{Y_0^b}) = \text{Per}^\circ(f) \ni 1$  (recall that a star map always has a fixed point by Theorem 2.4). So, we only have to prove that all periodic points of  $F$  in  $[-a, -b] \cup [b, a]$  are fixed points. Recall that we defined  $F$  so that  $F(a) = a$ ,  $F(-a) = -a$ ,  $F(b), F(-b) \in Y_0^b$  and  $F|_{[-a, -b]}$  and  $F|_{[b, a]}$  are affine. Thus, either  $F|_{[-a, -b]}$  is the identity map, or it is expansive; and the same holds for  $F|_{[b, a]}$ . Hence, the only periodic points of  $F$  in  $[-a, -b] \cup [b, a]$  are fixed points.

To end the proof of the theorem, we have to show that  $\text{Per}(F) = \text{Per}(0, F) \cup \text{Per}(G)$ . Since  $G(0) = 0$  and  $\rho_G(x) \neq 0$  for every  $x \in \mathbb{R} \setminus Z$ , it follows that  $\text{Per}(G) = \{1\} \cup \left( \bigcup_{\alpha \in (0, d]} \text{Per}(\alpha, G) \right)$ . Consequently,  $\text{Per}(0, F) \cup \text{Per}(G) = \text{Per}(0, F) \cup \left( \bigcup_{\alpha \in (0, d]} \text{Per}(\alpha, G) \right)$  because  $1 \in \text{Per}(0, F)$ . On the other hand, by definition,  $\text{Per}(F) = \text{Per}(0, F) \cup \left( \bigcup_{\alpha \in (0, d]} \text{Per}(\alpha, F) \right)$ . Therefore, we only have to show that  $\text{Per}(\alpha, F) = \text{Per}(\alpha, G)$  for every  $\alpha \in (0, d]$ .

Fix  $\alpha \in (0, d]$  and let  $x \in S$  be such that  $\rho_F(x) = \alpha$ . Then  $\rho_G(\varphi(x)) = \rho_F(x)$  by (4.2). We are going to prove that  $x$  is a periodic (mod 1) point of  $F$  of period  $n$  if and only if  $\varphi(x)$  is a periodic (mod 1) point of  $G$  of period  $n$ .

Assume first that  $x$  periodic (mod 1) point of period  $n$  for  $F$ , that is,  $F^n(x) = x + k$  for some  $k \in \mathbb{Z}$  and  $F^j(x) - x \notin \mathbb{Z}$  for all  $j = 1, 2, \dots, n-1$ . From (4.2), it follows that

$$G^n(\varphi(x)) = \varphi(F^n(x)) = \varphi(x + k) = \varphi(x) + k.$$

Therefore,  $\varphi(x)$  is a periodic point (mod 1) of  $G$  with period, either  $n$ , or a divisor of  $n$ . To see that  $x$  has indeed  $G$ -period (mod 1)  $n$ , suppose by way of contradiction that there exists  $j \in \{1, 2, \dots, n-1\}$  such that  $G^j(\varphi(x)) = \varphi(x) + l$  for some  $l \in \mathbb{Z}$ . Then  $\varphi(F^j(x)) = G^j(\varphi(x)) = \varphi(x) + l$ . Note that the fact that  $\rho_G(\varphi(x) + l) = \rho_G(\varphi(x)) = \alpha \neq 0$  implies that  $\varphi(F^j(x)) = \varphi(x) + l \notin Z$  by (4.3). Consequently, since  $\varphi^{-1}(y)$  is a point for every  $y \notin Z$ ,  $F^j(x) = x + l$ ; a contradiction.

Now assume that  $G^n(\varphi(x)) = \varphi(x) + k$  for some  $k \in \mathbb{Z}$  and  $G^j(\varphi(x)) - \varphi(x) \notin \mathbb{Z}$  for all  $j \in \{1, 2, \dots, n-1\}$ . From (4.2), it follows that  $\varphi(F^n(x)) = G^n(\varphi(x)) = \varphi(x) + k$ . As above,  $\rho_G(\varphi(x)) = \alpha \neq 0$  implies that  $\varphi(F^n(x)) = \varphi(x) + k \notin Z$  and thus  $F^n(x) = x + k$ . If there exists  $j \in \{1, 2, \dots, n-1\}$  such that  $F^j(x) \in x + \mathbb{Z}$ , then  $G^j(\varphi(x)) = \varphi(F^j(x)) \in \varphi(x) + \mathbb{Z}$ ; a contradiction. Thus  $x$  is periodic (mod 1) of period  $n$  for  $F$ .  $\square$

**Remark 4.1.** Theorem C gives a map with a non-degenerate rotation interval. It is even easier to obtain a degenerate interval (take  $G = \text{Id}$  in the proof), which shows that, for every  $f \in \mathcal{X}_3$ , there exists a map  $F \in \mathcal{L}_1(S)$  such that  $\text{Rot}(F) = \text{Rot}_{\mathbb{R}}(F) = \{0\}$  and  $\text{Per}(0, F) = \text{Per}(F) = \text{Per}^\circ(f)$ .  $\diamond$

One may wonder if Theorem C can be generalised in order to obtain a map  $F \in \mathcal{L}_1(S)$  such that  $\text{Rot}_{\mathbb{R}}(F) = [c, d]$  and  $\text{Per}(c, F) = q \cdot \text{Per}^\circ(f)$  for any  $f \in \mathcal{X}_3$  and any rational number  $c = p/q$  with  $p, q$  relatively prime. As we said in Subsection 2.4, the natural strategy is to use a block structure. The next result shows that this strategy fails.

**Theorem D.** *Let  $F \in \mathcal{L}_1(S)$  and let  $P$  be a periodic orbit (mod 1) of  $F$  with period  $nq$  and rotation number  $p/q$ . Assume that there exists  $x \in P$  such that  $\langle P_0(x) \rangle$  is homeomorphic to a 3-star and  $\langle P_1(x) \rangle \subset [n, n+1] \subset \mathbb{R}$  for some  $n \in \mathbb{Z}$ . Assume also that  $P_0(x)$  is a periodic orbit of type 3 of  $G := F^q - p$ ,  $F^i(m) \in \langle P_i(x) \rangle$  for  $i = 0, 1, \dots, q-1$  and  $G(m) = m$ , where  $m \in \mathbb{Z} \cap \langle P_0(x) \rangle$  denotes the branching point of  $\langle P_0(x) \rangle$ . Then  $\text{Per}(p/q, F) = q \cdot \mathbb{N}$ .*

Recall that, when  $P$  and  $G$  are as in Theorem D,

$$\forall x \in P, \forall i = 0, 1, \dots, q-1, P_i(x) := \{F^i(x), G(F^i(x)), G^2(F^i(x)), \dots, G^{n-1}(F^i(x))\}.$$

To simplify the notation, in what follows we shall set  $P_q(x) := P_0(x) + p$ .

Before proving Theorem D, we are going to develop the tools needed in its proof.

**Lemma 4.2.** *For all  $x \in P$  and all  $0 \leq i \leq q-1$ ,  $P_i(x)$  is a true periodic orbit of  $G$  of period  $n$ . In particular,  $P_i(x) = \{G^s(F^i(x)) : s \geq 0\}$ .*

*Proof.* Since the point  $F^i(x)$  belongs to  $P$ , it is periodic (mod 1) of period  $nq$  and rotation number  $p/q$  for  $F$ . Then the result follows from Lemma 3.2.  $\square$

**Definition 4.3.** We say that  $P$  has an *increasing block structure* whenever, for some  $x \in P$ ,

$$\max r(P_i(x)) < \min r(P_{i+1}(x)) \quad \forall i \in \{0, 1, \dots, q-1\}$$

(when  $i = q-1$  this amounts to  $\max r(P_{q-1}(x)) < \min r(P_0(x) + p)$ ).  $\diamond$



By the next lemma, the fact that a periodic (mod 1) orbit has an increasing block structure is independent on the point  $x$  chosen to build the blocks. So, the notion of *increasing block structure* is well defined.

**Lemma 4.4.** *For every  $z \in P$  there exist  $k \in \mathbb{Z}$  and  $j \in \{0, 1, \dots, q-1\}$  such that  $z \in P_j(x) + k$ ,  $P_i(z) = P_{i+j}(x) + k$  for all  $0 \leq i \leq q-1-j$  and  $P_i(z) = P_{i+j-q}(x) + k + p$  for all  $q-j \leq i \leq q$ .*

*Proof.* By definition, for every  $z \in P$  there exist  $k_1 \in \mathbb{Z}$  and  $j_1 \in \mathbb{N}$  such that  $z = F^{j_1}(x) + k_1$ . On the other hand, by Lemma 3.1(b),  $G^n(x) = F^{nq}(x) - np$ , for every  $x \in S$  and  $n \geq 0$ .

We can write  $j_1 = rq + j$  with  $r \geq 0$  and  $0 \leq j < q$ . Hence, by Lemma 4.2,

$$z = F^{rq+j}(x) + k_1 = F^{rq}(F^j(x)) + k_1 = G^r(F^j(x)) + k \in P_j(x) + k,$$

where  $k = k_1 + rp$ . This proves the first statement of the lemma.

By Lemma 4.2,  $P_i(z) = \{G^s(F^i(z)) : s \geq 0\}$ . From above and Lemma 3.1(a),

$$G^s(F^i(z)) = G^s(F^i(G^r(F^j(x)) + k)) = G^{r+s}(F^{i+j}(x)) + k$$

for every  $i, s \in \mathbb{N}$ . Consequently,  $P_i(z) = \{G^{r+s}(F^{i+j}(x)) : s \geq 0\} + k$ . If  $0 \leq i \leq q-1-j$ , by Lemma 4.2,  $P_{i+j}(x) = \{G^s(F^{i+j}(x)) : s \geq 0\} = \{G^{r+s}(F^{i+j}(x)) : s \geq 0\}$ , which proves the second statement of the lemma. In particular,  $P_q(z) = P_0(z) + p = P_j(x) + k + p$ .

If  $q-j \leq i < q$  then,  $G^{r+s}(F^{i+j}(x)) = G^{r+s+1}(F^{i+j-q}(x)) + p$  with  $i+j-q \geq 0$ . Hence, as above,  $P_i(z) = P_{i+j-q}(x) + k + p$ .  $\square$

We are going to show that every periodic (mod 1) orbit with period  $nq$  and rotation number  $p/q$  will have an increasing block structure by changing the lifting and the number  $p$ , if necessary. To this end, we want to look at the orbit (mod 1)  $P$  under the action of  $\bar{F} := F + \ell$  with  $\ell \in \mathbb{Z}$ . By Lemma 3.1(b,d), the  $\bar{F}$ -rotation number of  $P$  is  $\frac{p}{q} + \ell = \frac{p+q\ell}{q}$  while the  $\bar{F}$ -period is still  $nq$ . So, by using  $\bar{F}$  instead of  $F$ , we can define

$$\bar{P}_i(x) := \{\bar{F}^i(x), \bar{G}(\bar{F}^i(x)), \bar{G}^2(\bar{F}^i(x)), \dots, \bar{G}^{n-1}(\bar{F}^i(x))\}$$

for all  $i \in \{0, 1, \dots, q-1\}$ , where  $\bar{G} := \bar{F}^q - (p+q\ell)$ . We also set  $\bar{P}_q(x) := \bar{P}_0(x) + (p+q\ell)$ .

**Lemma 4.5.** *The following statements hold:*

- (a)  $\bar{G} = G$ .
- (b) For every  $i \in \{0, 1, \dots, q\}$ ,  $\bar{P}_i(x) = P_i(x) + i\ell$ .
- (c) Assume that  $\ell > \max r(P_i(x)) - \min r(P_{i+1}(x))$  for all  $i \in \{0, 1, \dots, q-1\}$ . Then, the orbit  $\bar{P}$  under  $\bar{F}$  has an increasing block structure, that is,  $\max r(\bar{P}_i(x)) < \min r(\bar{P}_{i+1}(x))$  for all  $i \in \{0, 1, \dots, q-1\}$ .

*Proof.* For every  $i \geq 0$ , we have

$$\bar{F}^i = (F + \ell)^i = F^i + i\ell$$

by Lemma 3.1(a-b). Hence,

$$\bar{G} := \bar{F}^q - (p+q\ell) = F^q + q\ell - (p+q\ell) = G,$$

and (a) holds.

For all  $i, j \geq 0$ , we have

$$\bar{G}^j(\bar{F}^i(x)) = G^j(F^i(x) + i\ell) = G^j(F^i(x)) + i\ell.$$

This gives (b) for  $i = 0, 1, \dots, q-1$ . The fact that  $\bar{P}_q(x) = P_q(x) + q\ell$  follows from (b) for  $i = 0$  and from the definition of these two sets.

Suppose that  $\ell$  satisfies the assumption of (c). From (b) and the choice of  $\ell$ , we have

$$\min r(\bar{P}_{i+1}(x)) - \max r(\bar{P}_i(x)) = \min r(P_{i+1}(x)) - \max r(P_i(x)) + \ell > 0$$

for every  $i \in \{0, 1, \dots, q-1\}$ . Hence (c) holds.  $\square$

*Proof of Theorem D.* It is not difficult to show that, for every  $\ell \in \mathbb{Z}$ ,  $\text{Per}(p/q, F) = \text{Per}((p + q\ell)/q, F + \ell)$ . Consequently, by changing the lifting and the number  $p$ , if necessary, we may assume that  $P$  has an increasing block structure by Lemma 4.5. Moreover, by replacing the point  $x$  by  $x - m$ , we may also assume that the branching point of  $\langle P_0(x) \rangle$  is 0 (that is,  $m = 0$ ). To simplify the notation, we shall omit the dependence from  $x$  of the blocks  $P_i(x)$  in what follows.

Let  $I_1, I_2, I_3$  denote the three  $P_0 \cup \{0\}$ -basic intervals in  $\langle P_0 \rangle$  that have an endpoint equal to 0 and let  $\mathcal{G}$  be the directed graph with vertices  $I_1, I_2, I_3$  such that there is an arrow  $I_i \rightarrow I_j$  if and only if  $\langle G(\partial I_i) \rangle \supset I_j$  (notice that arrows in  $\mathcal{G}$  are  $G$ -coverings and  $\mathcal{G}$  is a subgraph of the  $G$ -graph of  $\{I_1, I_2, I_3\}$ ). Since  $P_0$  is a periodic orbit of type 3 of  $G$  and  $G(0) = 0$ , we can label the intervals  $I_1, I_2, I_3$  so that

$$(4.4) \quad I_1 \xrightarrow{G} I_2 \xrightarrow{G} I_3 \xrightarrow{G} I_1 \quad \text{is a loop in } \mathcal{G}.$$

Let  $\mathcal{I}$  be the collection of  $P_i \cup \{F^i(0)\}$ -basic intervals for all  $0 \leq i \leq q$  (recall that  $F^i(0) \in \langle P_i \rangle$  by assumption, and thus the elements of  $\mathcal{I}$  are intervals in  $\bigcup_{i=1}^q \langle P_i \rangle$ ). We are going to relate paths in the  $F$ -graph of  $\mathcal{I}$  with coverings for  $G$ . Observe that, if  $\alpha = J_0 \xrightarrow{F} J_1 \xrightarrow{F} \dots \xrightarrow{F} J_q$  is a path in the  $F$ -graph of  $\mathcal{I}$  with  $J_0 \subset \langle P_0 \rangle$  then, since the blocks  $P_i$  have an increasing block structure,  $J_i$  is a basic interval of  $P_i \cup \{F^i(0)\}$  for all  $i \in \{0, 1, \dots, q\}$ . Moreover, the fact that  $\alpha$  is a path for  $F$  implies  $J_0 \xrightarrow{G} J_q - p$ . Reciprocally, if  $J_0 \xrightarrow{G} J_q$  is an arrow in  $\mathcal{G}$ , then

$$(4.5) \quad \exists J_1, \dots, J_{q-1} \in \mathcal{I}, \quad J_0 \xrightarrow{F} J_1 \xrightarrow{F} \dots \xrightarrow{F} J_q + p.$$

Let us prove (4.5). We have  $F^i(\partial J_0) \subset P_i \cup \{F^i(0)\}$  for all  $1 \leq i \leq q$  because  $\partial J_0 \subset P_0 \cup \{0\}$ . Then an induction on  $i = 1, \dots, q$  shows that, for all  $P_i \cup \{F^i(0)\}$ -basic intervals  $J \subset \langle F^i(\partial J_0) \rangle$ , there exists a path

$$(4.6) \quad J_0 \xrightarrow{F} J_1^J \xrightarrow{F} \dots \xrightarrow{F} J_{i-1}^J \xrightarrow{F} J$$

where  $J_j^J$  are  $P_j \cup \{F^j(0)\}$ -basic intervals for all  $1 \leq j \leq i - 1$ . The fact that  $J_0 \xrightarrow{G} J_q$  is an arrow in  $\mathcal{G}$  means that  $\langle G(\partial J_0) \rangle \supset J_q$ , that is,  $\langle F^q(\partial J_0) \rangle \supset J_q + p$ . Therefore (4.5) is given by (4.6) for  $i = q$  and  $J = J_q + p$ .

Combining (4.4) and (4.5), we see that there exist three pairwise different paths

$$\begin{aligned} \alpha_1 &= I_1 \xrightarrow{F} J_1 \xrightarrow{F} \dots \xrightarrow{F} I_2 + p \\ \alpha_2 &= I_2 \xrightarrow{F} J_2 \xrightarrow{F} \dots \xrightarrow{F} I_3 + p \\ \alpha_3 &= I_3 \xrightarrow{F} J_3 \xrightarrow{F} \dots \xrightarrow{F} I_1 + p \end{aligned}$$

in the  $F$ -graph of  $\mathcal{I}$ , of length  $q$ .

Now we consider two cases:

**Case 1:** *Two of the intervals  $J_i$  coincide.*

By relabelling, if necessary, we may assume that  $J_1 = J_2$ . Denote the interval  $J_1 = J_2$  by  $L$  and consider the following three loops:

$$\begin{aligned} \bar{\alpha}_1 &= L \xrightarrow{F} \dots \xrightarrow{F} I_2 + p \xrightarrow{F} L + p, \\ \bar{\alpha}_2 &= L \xrightarrow{F} \dots \xrightarrow{F} I_3 + p \xrightarrow{F} J_3 + p, \\ \bar{\alpha}_3 &= J_3 \xrightarrow{F} \dots \xrightarrow{F} I_1 + p \xrightarrow{F} L + p. \end{aligned}$$

Then

$$G(L) \supset L \cup J_3 \quad \text{and} \quad G(J_3) \supset L.$$

By assumption,  $\langle P_1 \rangle$  is included in  $[n, n + 1]$ . Thus  $\text{Int}(L)$  and  $\text{Int}(J_3)$  do not contain branching points since  $L \cup J_3 \subset \langle P_1 \rangle$ . Then the theorem holds by Proposition 3.8 and Lemma 3.2.

**Case 2:** *The intervals  $J_i$  are pairwise different.*

In this case, we have the following loop:

$$J_1 \xrightarrow{G} J_2 \xrightarrow{G} J_3 \xrightarrow{G} J_1.$$

By assumption,  $\langle P_1 \rangle$  is an interval in  $\mathbb{R}$ . Moreover,  $J_1, J_2, J_3$  are included in  $\langle P_1 \rangle$  and have pairwise disjoint interiors. Thus, by relabelling if necessary, we can assume that the intervals  $J_1, J_2, J_3$  are ordered as:

$$\begin{aligned} &\text{either } J_1 \leq J_2 \leq J_3, \\ &\text{or } J_1 \geq J_2 \geq J_3, \end{aligned}$$

with the convention that  $J_i \leq J_j$  if  $\max J_i \leq J_j$ . Both cases being similar, we assume that we are in the first one, that is,

$$\max J_1 \leq \min J_2 < \max J_2 \leq \min J_3.$$

Then,

- since  $J_1 \xrightarrow{G} J_2$ , there exists  $x_1 \in J_1$  such that  $G(x_1) = \min J_2$ ;
- since  $J_2 \xrightarrow{G} J_3$ , there exists  $x_2 \in J_2$  such that  $G(x_2) = \max J_3$  and
- since  $J_3 \xrightarrow{G} J_1$ , there exists  $x_3 \in J_3$  such that  $G(x_3) = \min J_1$ .

Now we set  $K = [x_1, x_2]$  and  $L = [x_2, x_3]$ . By continuity of  $G$ ,

$$\begin{aligned} G(K) &\supset [\min J_2, \max J_3] \supset [x_2, x_3] = L, \text{ and} \\ G(L) &\supset [\min J_1, \max J_3] \supset [x_1, x_3] = K \cup L, \end{aligned}$$

and the theorem holds by Proposition 3.8 and Lemma 3.2, as in Case 1.  $\square$

## 5. ORBITS IN THE BRANCHES

The aim of this section is to prove Theorems E and F, which deal with the periods forced by the periodic (mod 1) orbits contained in  $B$ .

**5.1. Situations that imply periodic points of all periods.** This subsection is devoted to two technical lemmas that characterise simple situations where  $\text{Per}(F) = \mathbb{N}$  in terms of images of distinguished points. They will also be used in Section 6.

Given  $F \in \mathcal{L}(S)$  and  $x \in S$  we define the map  $F_0$  by

$$(5.1) \quad F_0(x) := F(x) - r(F(x)).$$

To understand the map  $F_0$ , observe first that  $F_0(x) = 0$  whenever  $F(x) \in \mathbb{R}$ . Moreover, for every  $x \in S$  it follows that  $F(x) \in B$  if and only if  $r(F(x)) \in \mathbb{Z}$  (more precisely,  $F(x) \in B_m$  if and only if  $r(F(x)) = m$ ). Thus,  $F_0$  is a continuous map from the whole  $S$  to  $B_0$ . From Lemma 3.1(a), we deduce that  $F_0(x+k) = F_0(x)$  for all  $x \in S$  and all  $k \in \mathbb{Z}$  (that is,  $F_0 \in \mathcal{L}_0(S)$ ).

Recall that, if  $x, y$  are in the same branch  $B_m$ , then  $x < y$  means  $\text{Im}(x) < \text{Im}(y)$ ; the other notations related to the order in  $B_m$  are defined consistently.

**Lemma 5.1.** *Let  $F \in \mathcal{L}_1(S)$ . Let  $x, y \in B_0$  and  $m \in \mathbb{Z}$  be such that  $F(x) \in B_m$ ,  $x < y \leq F_0(x)$  and  $F(y) \notin \mathring{B}_m$ . Assume additionally that  $F(0) \notin (x+m, \max B_m]$ . Then,  $\text{Per}(F) = \mathbb{N}$ .*

*Proof.* First of all, observe that the assumptions  $x < y \leq F_0(x)$  and the definition of  $F_0$  imply that  $F(x) \geq y+m > x+m$ . Hence,  $F(0) \notin (x+m, \max B_m]$  implies  $F(0) \neq F(x)$ , and thus,  $x \neq 0$ .

Consider  $K = [x, y]$  and  $L = [0, x]$ , which are closed non-degenerate intervals in  $B_0$ . We have

$$\begin{aligned} F(K) &\supset \langle F(x), F(y) \rangle \supset \langle F(x), m \rangle \quad \text{because } F(x) \in B_m \text{ and } F(y) \notin \mathring{B}_m, \\ &\supset (K+m) \cup (L+m) \quad \text{because } F(x) \geq y+m > x+m \geq m. \end{aligned}$$

Moreover, since  $F(0) \notin (x + m, \max B_m]$  and  $y \leq F_0(x)$ ,

$$F(L) \supset \langle F(0), F(x) \rangle \supset K + m.$$

By Proposition 3.8, the map  $F - m$  has periodic points of all periods in  $K \cup L \subset B_0$ . Therefore,  $\text{Per}(F) = \mathbb{N}$  by Lemma 3.3. This ends the proof of the lemma.  $\square$

**Lemma 5.2.** *Let  $F \in \mathcal{L}_1(S)$ . Let  $x, y \in B_0$  and  $m \in \mathbb{Z}$  be such that  $F(x) \in B_m$ ,  $x < y \leq F_0(x)$  and  $|r(F(x)) - r(F(y))| \geq 1$ . Then,  $\text{Per}(F) = \mathbb{N}$ .*

**Remark 5.3.** Lemma 5.2 is a particular case of Lemma 5.1 whenever  $F(0)$  is not in a wrong place, i.e.  $F(0) \notin (x + m, \max B_m]$ .  $\diamond$

*Proof of Lemma 5.2.* We can assume additionally that  $F(0) \in B_m$  and  $F(0) > x + m$ , otherwise Lemma 5.1 gives the conclusion (see Remark 5.3). We shall also assume that  $r(F(y)) \leq m - 1$ ; the case  $r(F(y)) \geq m + 1$  follows in a similar way.

We set  $G := F - m$ . Then the three points  $x, y, G(x) = F_0(x)$  are in  $B_0$  and  $G(x) \geq y > x$ . According to Lemma 3.1(d),  $\text{Per}(F) = \text{Per}(G)$ , and thus we need to show that  $\text{Per}(G) = \mathbb{N}$ . We consider two cases.

**Case 1:**  $G(0) \geq y$ .

The proof of this case is similar to that of Lemma 5.1 by taking  $K = [x, y]$  and  $L = [-1, 0]$ . Since  $r(G(y)) \leq -1$  we have

$$G(K) \supset \langle G(x), G(y) \rangle \supset \langle G(x), -1 \rangle \supset K \cup L.$$

Moreover, since  $G(0) \geq y$ , we have  $G(-1) \in B_{-1}$ . Hence,

$$G(L) \supset \langle G(0), G(-1) \rangle \supset [x, y] \cup [-1, 0] = K \cup L.$$

By Proposition 3.8, the map  $G$  has periodic points of all periods in  $K \cup L$ .

**Case 2:**  $x < G(0) < y$ .

In this case, we set  $K = [x, y]$  and  $L = \langle -1, x \rangle$ , and we endow the interval  $L$  with the order  $<_L$  such that  $-1 = \min L$ . Observe that  $0 \neq x$  because  $G(0) < y \leq G(x)$ , and thus  $L$  contains the branching point 0 in its interior.

As in the previous case,

$$\begin{aligned} G(K) &\supset K \cup L, \\ G(L) &\supset \langle G(-1), G(x) \rangle \supset \langle -1, G(x) \rangle \supset K \cup L. \end{aligned}$$

However, observe that the covering is negative in the first case and positive in the second. In other words, we have  $K \xrightarrow[G]{-} K, L$  and  $L \xrightarrow[G]{+} K, L$ . Moreover,  $(K + \mathbb{Z}) \cap (L + \mathbb{Z}) = \{x\} + \mathbb{Z}$ , and  $G(x) \notin L + \mathbb{Z}$ . Thus Lemma 3.16 applies and gives  $\text{Per}(G) \supset \mathbb{N} \setminus \{2\}$ . So, we have to prove that  $2 \in \text{Per}(G)$ . To this end, we shall consider several subcases and several loops.

Since  $G(x) \geq y$  and  $r(G(y)) \leq -1$ , there exist points  $x \leq x_1 < x_2 < \alpha < y$  in  $B_0$  such that  $G(x_1) = y$ ,  $G(x_2) = x_1$  and  $G(\alpha) = 0$ . Moreover, we can take  $x_2$  and  $\alpha$  so that

$$\begin{aligned} x_2 &= \max\{t \in [x_1, y] : G(t) = x_1\}, \text{ and} \\ \alpha &= \max\{t \in [x_2, y] : G(t) = 0\} = \max\{t \in [x_2, y] : G(t) \in B_0\}. \end{aligned}$$

Now we consider two subcases.

**Subcase 2.1:**  $x < G(0) \leq \alpha$ .

We look at the interval  $[x_2, \alpha]$ . Observe that, by Lemma 3.1(a),

$$\begin{aligned} G^2(x_2) &= G(x_1) = y > x_2 \text{ and} \\ G^2(\alpha) &= G(0) \leq \alpha. \end{aligned}$$

Hence,  $G^2([x_2, \alpha]) \supset [x_2 + \alpha]$  and, since  $G^2$  is continuous and there is no branching point in  $[x_2, \alpha]$ , there exists a point  $z \in (x_2, \alpha]$  such that  $G^2(z) = z$ . From the definition of  $x_2$ , it follows that  $G([x_2, \alpha]) \cap [x_2, \alpha] = \emptyset$ . Therefore,  $(G(z) + \mathbb{Z}) \cap [x_2, \alpha] = \emptyset$  and, consequently,  $G(z) - z \notin \mathbb{Z}$ . Thus,  $z$  is periodic (mod 1) point of period 2.

**Subcase 2.2:**  $\alpha < G(0) < y$

In this subcase, we need a couple of additional points. Since  $G(0) \in \mathring{B}_0$ , it follows that  $G(-1) \in \mathring{B}_{-1}$  and, hence, there exists a point  $\beta \in (-1, 0)$  such that  $G(\beta) = 0$ . Using again that  $G(\alpha) = 0$  and  $r(G(y)) \leq -1$ , we see that there exists a point  $u < \alpha < y$  such that  $G(u) = \beta$ . Now we look at the interval  $[\alpha, u]$ . We have

$$\begin{aligned} G^2(\alpha) &= G(0) > \alpha \text{ and} \\ G^2(u) &= G(\beta) = 0 < u. \end{aligned}$$

Hence, there exists a point  $z \in (\alpha, u) \subset B_0$  such that  $G^2(z) = z$ . From the definition of  $\alpha$ , it follows that  $G((\alpha, u)) \cap \mathring{B}_0 = \emptyset$ . So, as in the previous case,  $G(z) - z \notin \mathbb{Z}$  and  $z$  is a periodic (mod 1) point of period 2. This ends the proof of the lemma.  $\square$

**5.2. Proofs of Theorem E and Theorem F.** The next lemma relates the maps  $F$  and  $F_0$  in the situation that interests us.

**Lemma 5.4.** *Let  $F \in \mathcal{L}_d(S)$ . Then the following statements hold:*

- (a) *Assume that there exists  $x \in \mathring{B}_0$  and  $n \in \mathbb{N}$  such that  $F_0^i(x) \in \mathring{B}_0$  for all  $0 \leq i \leq n$ . Then,  $F^i(x) \in \cup_{m \in \mathbb{Z}} \mathring{B}_m$  for all  $0 \leq i \leq n$ .*
- (b) *Assume that there exists  $x \in B$  and  $n \in \mathbb{N}$  such that  $F^i(x) \in B$  for all  $0 \leq i \leq n$ . Then*

$$F^n(x) = F_0^n(x) + \sum_{k=0}^{n-1} d^k r(F(F_0^{n-1-k}(x))) \in F_0^n(x) + \mathbb{Z}.$$

*Proof.* Observe that if  $F(x) \in \mathbb{R}$  then  $F_0(x) = 0 \notin \mathring{B}_0$ . Thus (a) holds. Statement (b) follows from the iterative use of Lemma 3.1(a) and the definition of  $F_0$ .  $\square$

Given a periodic (mod 1) orbit  $P$  that lives in the branches (that is,  $P \subset B$ ), we set

$$(5.2) \quad P_0 := P \cap B_0 = \{x - r(x) : x \in P\}.$$

**Remark 5.5.** From the definitions of  $F_0$  and  $P_0$ , we deduce that  $F_0(P_0) \subset P_0$  and the cardinality of  $P_0$  coincides with the  $F$ -period of  $P$ .  $\diamond$

The next lemma summarises the relation between  $P$ ,  $P_0$  and  $F_0$ . Its proof is omitted since it follows easily from Lemma 5.4 and Remark 5.5.

**Lemma 5.6.** *Let  $F \in \mathcal{L}(S)$  and let  $P$  be a periodic orbit (mod 1) of  $F$  that lives in the branches. Then  $P_0$  is a periodic orbit of  $F_0$  and the  $F_0$ -period of  $P_0$  coincides with the  $F$ -period of  $P$ .*

We are ready to prove Theorems E and F. We recall their statement before the proof.

**Theorem E.** *Let  $F \in \mathcal{L}(S)$  and let  $P$  be a periodic (mod 1) orbit of  $F$  of period  $p$  that lives in the branches. Then  $\text{Per}(F) \supset \text{Ssh}(p)$ . Moreover, for every  $d \in \mathbb{Z}$  and every  $p \in \mathbb{N}_{\text{Sh}}$ , there exists a map  $F_p \in \mathcal{L}_d(S)$  such that  $\text{Per}(F_p) = \text{Ssh}(p)$ .*

*Proof.* Since  $\langle P_0 \rangle$  is a compact interval included in  $B_0$ , the retraction on  $\langle P_0 \rangle$  is the continuous map  $r_{\langle P_0 \rangle}: S \rightarrow \langle P_0 \rangle$  defined by:

$$r_{\langle P_0 \rangle}(x) = \begin{cases} x & \text{if } x \in \langle P_0 \rangle \\ \max P_0 & \text{if } x \in B_0 \text{ and } x \geq \max P_0, \\ \min P_0 & \text{otherwise.} \end{cases}$$

We define  $\psi := r_{\langle P_0 \rangle} \circ F_0|_{\langle P_0 \rangle}$ . Then  $\psi: \langle P_0 \rangle \rightarrow \langle P_0 \rangle$  is a continuous interval map such that  $\psi|_{P_0} = F_0|_{P_0}$  and

$$(5.3) \quad \psi(z) = F_0(z) \text{ for every } z \in \langle P_0 \rangle \setminus \psi^{-1}(\{\min P_0, \max P_0\}).$$

By Lemma 5.6,  $P_0$  is a periodic orbit of  $\psi$  of period  $p$ . Fix  $q \in \text{Ssh}(p)$  with  $q \neq p$ . By Sharkovsky's theorem on the interval (see [20, 21] or Theorem 2.4 for  $n = 2$ ), there exists a periodic orbit  $Q \subset \langle P_0 \rangle$  of  $\psi$  of period  $q$ . We have to show that  $F$  has a periodic orbit (mod 1) of period  $q$ .

Notice that  $Q \cap P_0 = \emptyset$  and  $Q \cap \psi^{-1}(P_0) = \emptyset$  since both are periodic orbits of  $\psi$  of different period. Therefore,  $Q \subset \overset{\circ}{B}_0$  and  $\psi|_Q = F_0|_Q$  by (5.3). Let  $d$  denote the degree of  $F$ . Then, by Lemma 5.4,

$$(5.4) \quad \forall x \in Q, \forall n \in \mathbb{N}, F^n(x) = \psi^n(x) + \sum_{k=0}^{n-1} d^k r(F(\psi^{n-1-k}(x))) \in \psi^n(x) + \mathbb{Z}.$$

To prove that  $F$  has a periodic (mod 1) point of period  $q$ , we take any  $x \in Q$  and we prove that  $F^k(x) - x \notin \mathbb{Z}$  for  $k = 1, 2, \dots, q-1$  and  $F^q(x) - x \in \mathbb{Z}$ . This last statement follows trivially from (5.4) because  $\psi^q(x) = x$ . Assume that  $F^k(x) = x + l$  for some  $k \in \{1, 2, \dots, q-1\}$  and some  $l \in \mathbb{Z}$ . Then, again from (5.4),  $\psi^k(x) = x + \tilde{l}$  for some  $\tilde{l} \in \mathbb{Z}$ . Since both  $x$  and  $\psi^k(x)$  belong to  $Q \subset \langle P_0 \rangle \subset B_0$ , it follows that  $\tilde{l} = 0$  and, hence,  $\psi^k(x) = x$ ; a contradiction. Consequently,  $F^k(x) - x \notin \mathbb{Z}$  for  $k = 1, 2, \dots, q-1$ .

The proof of the second part is easy. Fix  $p \in \mathbb{N}_{\text{Sh}}$ . By [22] (see also [7]), there exists a map  $f_p \in \mathcal{C}^0([0, 1])$  such that the set of periods of  $f_p$  is precisely  $\text{Ssh}(p)$ . Now we define the map  $F_p \in \mathcal{L}_d(S)$  as follows. First we define  $F_p$  on  $B_0$  by setting

$$\forall x \in [0, 1], F_p(x\iota) := f_p(x)\iota,$$

where  $\iota$  denotes the square root of  $-1$ . Notice that this formula defines  $F_p(0)$ . Then we define  $F_p$  such that it maps the interval  $[0, 1]$  onto  $\langle F_p(0), F_p(0) + d \rangle$  in an expansive (affine) way. With this we have defined  $F_p$  in the set of all  $x \in S$  such that  $r(x) \in [0, 1]$ . Finally, we extend  $F_p$  to the whole  $S$  by the formula  $F_p(x) = F_p(x - \lfloor r(x) \rfloor) + d \lfloor r(x) \rfloor$ , where  $\lfloor \cdot \rfloor$  denotes the integer part function. Clearly, the map  $F_p$  is continuous and has degree  $d$ . Moreover, each periodic orbit of  $f_p$  corresponds to a periodic orbit of  $F_p|_{B_0}$ . Hence,  $\text{Per}(F_p) \supset \text{Ssh}(p)$ . To end the proof of the theorem we have to show that, indeed, both sets coincide.

To see this, we note that  $F_p(B) \subset B$  because  $F_p(B_0) \subset B_0$ . We claim that  $F_p$  has no periodic (mod 1) points in  $S \setminus B = \mathbb{R} \setminus \mathbb{Z}$  other than fixed (mod 1) points. Indeed, when  $d = 0$ ,  $F_p(\mathbb{R}) = F_p(0) \in B_0$  and there are no periodic (mod 1) points in  $\mathbb{R} \setminus \mathbb{Z}$ . When  $d \neq 0$ , there exist points  $0 \leq x_1 < x_2 \leq 1$  such that  $F_p([0, x_1]) \subset B_0$ ,  $F_p([x_2, 1]) \subset B_d$  and  $F_p([x_1, x_2]) = [0, d]$ . Therefore, there are no periodic (mod 1) points in  $[0, x_1] \cup [x_2, 1]$  other than, perhaps, 0 and 1 (which are already contained in  $B$ ); and the only periodic (mod 1) points in  $(x_1, x_2)$  are fixed (mod 1) points because  $F_p|_{(x_2, x_2)}$  is expansive. This proves the claim. Since  $F_p$  has already fixed (mod 1) points in  $B$ , there are no new periods of  $F_p$  in  $S \setminus B$ .

Now we are going to show that, if  $x \in B$  is a periodic (mod 1) point of period  $q$ , then  $q \in \text{Ssh}(p)$ . Clearly,  $\tilde{x} := x - r(x) \in B_0$  and  $F_p^n(\tilde{x}) \in B_0$  for every  $n \geq 0$ . Then, by Lemma 3.3,  $\tilde{x}$  is a periodic point of  $F_p$  of period  $q$  whose orbit is contained in  $B_0$ . Therefore,  $q$  is a period of the original map  $f_p$  and, thus,  $\text{Per}(F_p) = \text{Ssh}(p)$ . This ends the proof of the theorem.  $\square$

**Theorem F.** *Let  $F \in \mathcal{L}_1(S)$  and let  $Q$  be a large orbit of  $F$  such that  $Q$  lives in the branches. Then  $\text{Per}(F) = \mathbb{N}$ .*

*Proof.* Let  $P = Q + \mathbb{Z} \subset B$  be the orbit (mod 1) corresponding to  $Q$  and set  $q := \text{Card}(Q)$ . Recall that  $F_0$  and  $P_0$  are defined by (5.1) and (5.2). By Lemma 5.6,  $P_0$  is a periodic orbit of  $F_0$  of period  $q$ . We are going to show, by a recursive argument, that there exist  $x, y \in P_0$  such that  $x < y \leq F_0(x)$  and  $r(F(x)) \neq r(F(y))$ . Then the theorem follows from Lemma 5.2.

We set  $A_0 := \{\min P_0\}$  and, for all  $i \geq 0$ , we define

$$A_{i+1} := \{z \in P_0 : z \leq \max F_0(A_i)\}.$$

It follows from this definition that, if  $\max F_0(A_i) \leq \max A_i$ , then  $F_0(A_i) \subset A_i$ , which implies that  $A_i = P_0$  because  $A_i$  is included in  $P_0$ , which is a periodic orbit of  $F_0$ . Therefore, either  $A_i \subsetneq A_{i+1}$  (when  $\max F_0(A_i) > \max A_i$ ), or  $A_i = P_0$ . Clearly,  $A_{i+1} = P_0$  whenever  $A_i = P_0$ . This implies that

$$(5.5) \quad \forall i \geq 0, A_i \subset A_{i+1} \quad \text{and} \quad \forall i \geq q-1, A_i = P_0.$$

On the other hand, the function  $r(F(\cdot))$  is not constant on  $P_0$ . To prove this, assume that there exists  $m \in \mathbb{Z}$  such that

$$(5.6) \quad r(F(P_0)) = \{m\}.$$

Choose  $z \in P_0$  and let  $s \in \mathbb{N}$  be such that  $z + s \in Q$ . Then, since  $Q$  is a true periodic orbit of  $F$  and  $P_0$  is a periodic orbit of  $F_0$ , both of period  $q$ , we have  $F^q(z + s) = z + s$  and  $F_0^q(z) = z$ . Lemma 5.4(b) implies that  $F^q(z) = F_0^q(z) + qm$  (note that  $\forall k, r(F(F_0^{q-1-k})) = m$  by (5.6)). We then have

$$\begin{aligned} z + s &= F^q(z + s) = F^q(z) + s \quad \text{by Lemma 3.1(a)} \\ &= F_0^q(z) + qm + s \\ &= z + qm + s. \end{aligned}$$

Hence,  $m = 0$  and, consequently,  $\forall n \geq 0, F^n(z + s) = F^n(z) + s = F_0^n(z) + s$ , again by Lemma 5.4(b) and (5.6). So,

$$\begin{aligned} Q &= \{F^n(z + s) : n = 0, 1, \dots, q-1\} \\ &= \{F_0^n(z) : n = 0, 1, \dots, q-1\} + s \\ &= P_0 + s \subset B_s. \end{aligned}$$

This contradicts the fact that  $Q$  is a large orbit and, hence, the function  $r(F(\cdot))$  is not constant on  $P_0$ . Using this fact and (5.5), we see that there exists  $1 \leq k \leq q-1$  such that the function  $r(F(\cdot))$  is constant on  $A_{k-1}$  (and hence its value is  $r(F(\min P_0))$ ) but there exists  $y \in A_k \setminus A_{k-1}$  such that  $r(F(y)) \neq r(F(\min P_0))$ . By definition,  $y \leq \max F_0(A_{k-1})$ . Let  $x \in A_{k-1}$  be such that  $F_0(x) = \max F_0(A_{k-1})$ . Then, since  $y \notin A_{k-1}$ , we have  $x < y \leq \max F_0(A_{k-1}) = F_0(x)$ . Moreover,  $r(F(\min P_0)) = r(F(x))$  because  $x \in A_{k-1}$ , and thus  $r(F(y)) \neq r(F(x))$ . This ends the proof of the theorem.  $\square$

## 6. PERIODS (mod 1) WHEN 0 IS IN THE INTERIOR OF THE ROTATION INTERVAL

This section is devoted to prove the next theorem.

**Theorem G.** *Let  $F \in \mathcal{L}_1(S)$ . If  $\text{Int}(\text{Rot}_{\mathbb{R}}(F)) \cap \mathbb{Z} \neq \emptyset$ , then  $\text{Per}(F)$  is equal to, either  $\mathbb{N}$ , or  $\mathbb{N} \setminus \{1\}$ , or  $\mathbb{N} \setminus \{2\}$ . Moreover, there exist maps  $F_0, F_1, F_2 \in \mathcal{L}_1(S)$  with  $0 \in \text{Int}(\text{Rot}_{\mathbb{R}}(F_i))$  for  $i = 0, 1, 2$  such that  $\text{Per}(F_0) = \mathbb{N}$ ,  $\text{Per}(F_1) = \mathbb{N} \setminus \{1\}$  and  $\text{Per}(F_2) = \mathbb{N} \setminus \{2\}$ .*

In the first subsection, we construct the maps  $F_0, F_1$  and  $F_2$  from the statement of Theorem G. Then, in Subsection 6.2, we prove two lemmas, both giving conditions to obtain  $\text{Per}(F) \supset \mathbb{N} \setminus \{1\}$ . Finally we prove the first statement of Theorem G in the last and biggest subsection.

**6.1. Construction of examples.** We give below two examples of maps with  $0 \in \text{Int}(\text{Rot}_{\mathbb{R}}(F))$  and  $\text{Per}(F) = \mathbb{N} \setminus \{1\}$  (resp.  $\text{Per}(F) = \mathbb{N} \setminus \{2\}$ ). The case  $0 \in \text{Int}(\text{Rot}_{\mathbb{R}}(F))$  and  $\text{Per}(F) = \mathbb{N}$  is trivially obtained from a lifting of a circle map with this property (just extend the map to  $S$  by collapsing  $B_0$  to  $F(0)$  under the action of  $F$ ); see e.g. [7, Section 3.10] for such circle maps.

**Example 6.1.** We are going to build a map  $F \in \mathcal{L}_1(S)$  such that  $0 \in \text{Int}(\text{Rot}_{\mathbb{R}}(F))$  and  $\text{Per}(F) = \mathbb{N} \setminus \{1\}$ . Moreover, there is a large orbit of period  $n$  for some fixed  $n \geq 3$ , which shows that the existence of a large orbit is not enough to imply all periods (mod 1).

We fix an integer  $n \geq 3$ . Let  $a_0, a_1, \dots, a_n \in [0, 1]$  be such that  $0 = a_0 < a_1 < a_2 < \dots < a_{n-1} < a_n = 1$ . We set  $A_i = [a_{i-1}, a_i]$  for all  $1 \leq i \leq n$ . We define  $F \in \mathcal{L}_1(S)$  such that  $F(a_i) = a_{i-1}$  for all  $3 \leq i \leq n$ ,  $F(a_2) = \max B_0$ ,  $F(a_1) = 0$ ,  $F(\max B_0) = a_2 + 1$ , and  $F$  is affine on  $B_0$  and  $A_i$  for all  $1 \leq i \leq n$ . The map  $F$  and its Markov graph are illustrated in Figure 2.

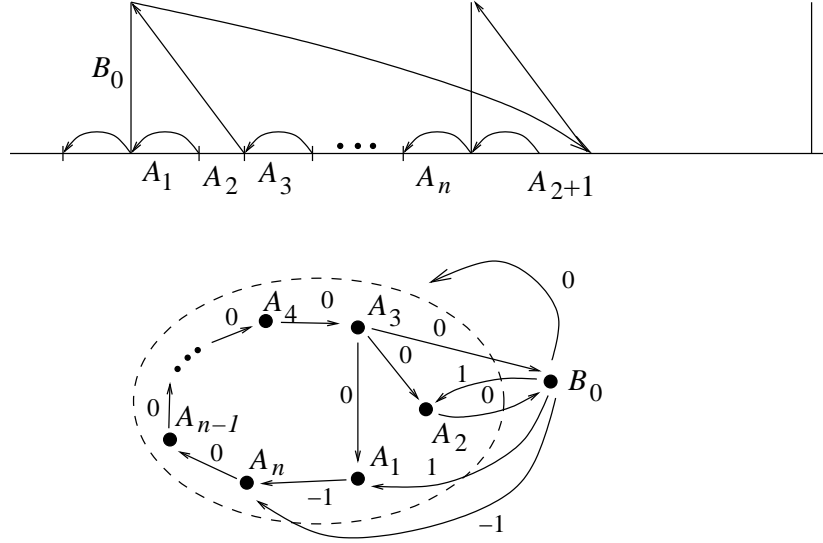

FIGURE 2. Above: the map  $F$  of Example 6.1. Below: its Markov graph. The arrow from  $B_0$  to the dotted set means that there are arrows  $B_0 \xrightarrow{0} A_i$  for all  $1 \leq i \leq n$ .

By using the tools from [8, Subsection 6.1] one can compute from its Markov graph that  $\text{Per}(F) = \text{Per}(0, F) = \{n \geq 2\}$  and  $\text{Rot}_{\mathbb{R}}(F) = \left[-\frac{1}{n-1}, \frac{1}{2}\right] \ni 0$ . The loop

$$B_0 \xrightarrow{1} A_1 \xrightarrow{-1} A_n \xrightarrow{0} A_{n-1} \xrightarrow{0} \dots \xrightarrow{0} A_3 \xrightarrow{0} B_0$$

gives a large orbit of period  $n$ .  $\diamond$

**Example 6.2.** We are going to build a map  $F \in \mathcal{L}_1(S)$  such that  $0 \in \text{Int}(\text{Rot}_{\mathbb{R}}(F))$  and  $\text{Per}(F) = \mathbb{N} \setminus \{2\}$ .

Let  $t_0, t_1, t_2, z_0, z_1 \in [0, 1]$  be such that  $0 < t_2 < t_1 < t_0 < z_0 < z_1 < 1$ . We set  $I_2 = [0, t_2]$ ,  $I_1 = [t_2, t_1]$ ,  $I_0 = [t_1, t_0]$ ,  $C = [t_0, z_0]$ ,  $J_0 = [z_0, z_1]$  and  $J_1 = [z_1, 1]$ . We define  $F \in \mathcal{L}_1(S)$  such that  $F(t_0) = t_1$ ,  $F(t_1) = t_2$ ,  $F(t_2) = t_0 - 1$ ,  $F(z_0) = z_1$ ,  $F(z_1) = \max B_1$ ,  $F(\max B_0) = z_0$ ,  $F(0) = 0$  and  $F$  is affine on  $B_0, I_0, I_1, I_2, J_0, J_1, C$ . The map  $F$  and its Markov graph are illustrated on Figure 3.

By using the tools from [8, Subsection 6.1] and using the loops  $C \xrightarrow{0} J_0 \xrightarrow{1} B_0 \xrightarrow{0} C$ ,  $C \xrightarrow{0} C$  and  $C \xrightarrow{0} I_0 \xrightarrow{0} I_0 \xrightarrow{-1} C$ , one can compute that  $\text{Per}(F) = \mathbb{N} \setminus \{2\}$  and  $\text{Rot}_{\mathbb{R}}(F) = \left[-\frac{1}{3}, \frac{1}{3}\right]$ .  $\diamond$

**6.2. Situations that imply periodic points of all periods except 1.** The aim of this subsection is to prove Lemmas 6.3 and 6.4 below, both giving conditions to obtain  $\text{Per}(F) \supset \mathbb{N} \setminus \{1\}$ . They will be used in the proof of Theorem G.



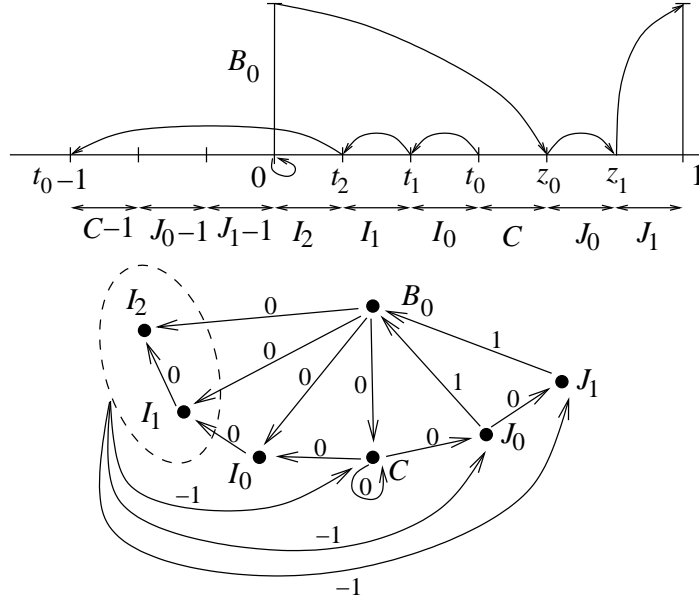

FIGURE 3. Above: the map  $F$  of Example 6.2. Below: its Markov graph. The arrows from the dotted set mean that there are arrows  $I_i \xrightarrow{-1} C, J_0, J_1$  for  $i = 1, 2$ .

There is a common idea in the hypotheses of both lemmas: some points of  $\mathbb{R}$  go to the left whereas others go sufficiently to the right and have an orbit passing through the branches. In Lemma 6.3, the assumption is that there is a point  $x \in \mathbb{R}$  such that  $F(x)$  is in the branch  $B_0$  and  $F^2(x)$  is much to the right (or much to the left) of  $F(0)$ . In Lemma 6.4, assumption (a) means that all points in  $\mathbb{R}$  go rather to the left (or at least do not go much to the right) under one iteration, whereas assumption (b) implies that there is one point  $x_0$  in  $\mathbb{R}$  whose orbit tends to  $+\infty$ ; because of (a), the orbit of  $x_0$  must pass through the branches.

Intuitively, the fact that some points of the real line go to the left whereas others go to the right is clearly related to the fact that there exist points  $x, x' \in \mathbb{R}$  such that  $\rho_F(x) < 0$  and  $\rho_F(x') > 0$ , and hence  $0 \in \text{Int}(\text{Rot}_{\mathbb{R}}(F))$ .

**Lemma 6.3.** *Let  $F \in \mathcal{L}_1(S)$ . Suppose that there exists  $y_0 \in F(\mathbb{R}) \cap B_0$  such that, either  $r(F(y_0)) \geq \lceil r(F(0)) \rceil + 1$ , or  $r(F(y_0)) \leq \lfloor r(F(0)) \rfloor - 1$ . Then  $\text{Per}(F) \supset \mathbb{N} \setminus \{1\}$ .*

**Lemma 6.4.** *Let  $F \in \mathcal{L}_1(S)$ . Suppose that*

- (a)  $\forall x \in \mathbb{R}, x < 0 \implies r(F(x)) < 0$ ,
- (b)  $\exists x_0 \in \mathbb{R}, \rho(x_0) > 0$ .

*Then  $\text{Per}(F) \supset \mathbb{N} \setminus \{1\}$ .*

We also need two lemmas that, unfortunately, are rather technical. Roughly speaking, the conclusion of Lemma 6.5 is that, either we have a “good” point in  $F(\mathbb{R})$  and we may hope to apply Lemma 6.3, or we are in a “good” situation in view of Lemmas 5.1 or 5.2. Lemma 6.6 summarises the various conclusions we can obtain in this situation.

**Lemma 6.5.** *Let  $F \in \mathcal{L}_1(S)$ ,  $z \in \mathbb{R}$  and  $u \in \text{Orb}(z, F) \setminus \mathbb{R}$ . Then there exists  $y \in \text{Orb}(z, F) \setminus \mathbb{R}$  verifying*

$$y - r(y) \leq u - r(u) \quad \text{and} \quad r(F(y)) - r(y) = r(F(u)) - r(u)$$

*and such that*

- either  $y \in F(\mathbb{R})$ ,
- or there exists  $x \in B_0$  such that  $x < y - r(y) \leq F_0(x)$  and  $r(F(x)) \neq r(F(y)) - r(y)$ .

**Lemma 6.6.** *Let  $F \in \mathcal{L}_1(S)$ ,  $z \in \mathbb{R}$  and  $u \in \text{Orb}(z, F) \cap B_0$ . Then, there exists  $y \in \text{Orb}(z, F) \cap B_0$  such that  $y \leq u$  and  $r(F(y)) = r(F(u))$ , and one of the following situations occurs:*

- $y \in F(\mathbb{R})$ ,
- $\text{Per}(F) = \mathbb{N}$ ,
- $y \notin F(\mathbb{R})$  and there exists a point  $x \in B_0$  such that  $x < y \leq F_0(x)$ ,  $F(0) \in (x + m, \max B_m]$  and  $F(y) \in (m - 1, m + 1) \setminus \{m\} \subset \mathbb{R}$ , where  $m := r(F(x)) \in \mathbb{Z}$ .

Next we prove the above four lemmas.

*Proof of Lemma 6.3.* We assume that  $r(F(y_0)) \geq \lceil r(F(0)) \rceil + 1$ ; the other case is symmetric. In particular  $0 \neq y_0 \in \mathring{B}_0$ . By the continuity of  $F$ , there exist  $y_1, y_2 \in B_0$ ,  $y_1 < y_2 \leq y_0$ , such that  $F(y_1) = \lceil r(F(0)) \rceil$  and  $F(y_2) = \lceil r(F(0)) \rceil + 1$ . Let  $D = [y_1, y_2] \subset B_0$ . We have  $F(D) \supset [F(y_1), F(y_2)]$ , and hence  $D \rightarrow [0, 1] + \lceil r(F(0)) \rceil$ . Let  $\tilde{a} \in \mathbb{R}$  be such that  $F(\tilde{a}) = \max F(\mathbb{R}) \cap B_0$ ,  $q = \lfloor \tilde{a} \rfloor$  and  $a = \tilde{a} - q \in [0, 1)$ . We have  $F(a) \in B_{-q}$  and  $F(a) + q \geq y_0$ . In the rest of the proof, all the coverings are for the map  $F$  and the notation  $I \rightarrow J \pmod{1}$  means that  $I \rightarrow J + n$  for some  $n \in \mathbb{Z}$ .

**Case 1:**  $F(0) \notin B$  (see Figure 5).

This assumption implies that  $y_1 \neq 0$ , and thus  $D \cap \mathbb{R} = \emptyset$ . Set  $A_1 = [0, a]$  and  $A_2 = [a, 1]$ . Since  $F(a) \in B_{-q}$ , the set  $F(A_1)$  contains  $\langle F(0), F(a) \rangle \supset \langle F(0), -q \rangle$ , and similarly  $F(A_2)$  contains  $\langle -q, F(1) \rangle = \langle -q, F(0) + 1 \rangle$ . Thus, if  $F(0) \leq a - q - 1$  then  $A_1 \rightarrow A_2 - q - 1$ , and if  $F(0) \geq a - q - 1$  then  $A_2 \rightarrow A_1 - q$ . Moreover, we have  $A_1 \rightarrow D - q$  and  $A_2 \rightarrow D - q$  because  $F(a) + q \geq y_0 \geq y_2$  and  $F(0), F(1) \notin B$ . Therefore we have one of the covering graphs of Figure 4.

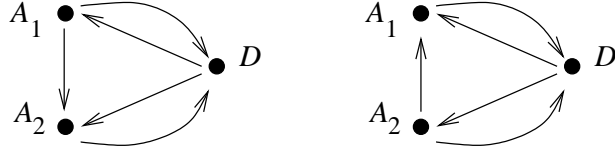

FIGURE 4. The two possible covering graphs in case 1 (arrows are  $\pmod{1}$ ).

Suppose that we are in the first case, i.e.  $A_1 \rightarrow A_2 \pmod{1}$  (see Figure 5). Since  $A_2 \rightarrow D \pmod{1}$ , there exists  $c \in A_2$  such that  $F(c) = y_1 \pmod{1}$ . Moreover  $c \notin \{a, 1\}$  because  $F(a) \geq y_2$  and  $F(1) \in \mathbb{R}$ . Similarly, there exist  $y_3 \in (y_1, y_2)$  such that  $F(y_3) = c \pmod{1}$ , and  $b \in (a, c)$  such that  $F(b) = y_3 \pmod{1}$ . Let  $D' = [y_1, y_3] \subset D$  and  $A'_2 = [b, c] \subset A_2$ . Then  $D' \rightarrow A_1 \cup A'_2 \pmod{1}$  and  $A_2 \rightarrow D' \pmod{1}$ . That is, we have the covering graph shown on the left picture of Figure 4 by replacing  $A_2$  and  $D$  by  $A'_2$  and  $D'$ , respectively. Moreover, the sets  $A_1 + \mathbb{Z}$ ,  $A'_2 + \mathbb{Z}$  and  $D' + \mathbb{Z}$  are disjoint, and  $A_1, A_2, D'$  contain no branching point in their interior. Therefore, to show that there exist periodic  $\pmod{1}$  points of period  $n$ , it is enough to show that there exists a non-repetitive loop of length  $n$  in the covering graph. Consider the following loops in the covering graph:

$$\mathcal{C}_2 := D' \rightarrow A_1 \rightarrow D', \quad \mathcal{C}'_2 := D' \rightarrow A'_2 \rightarrow D', \quad \mathcal{C}_3 := D' \rightarrow A_1 \rightarrow A'_2 \rightarrow D',$$

where the arrows are  $\pmod{1}$ . Fix  $n \geq 2$ . If  $n$  is even, we write  $n = 2m$  and we consider the loop  $\mathcal{C}'_2(\mathcal{C}_2)^{m-1}$ . If  $n$  is odd, we write  $n = 2m + 1$  and we consider the loop  $\mathcal{C}_3(\mathcal{C}_2)^{m-1}$ . In both cases, we obtain a non-repetitive loop of length  $n$ . By Proposition 3.7, there exists a point  $x \in D'$  such that  $F^n(x) - x \in \mathbb{Z}$  and

$$\forall 0 \leq i \leq m - 1, F^{n-2i}(x) \in D' + \mathbb{Z}, \quad \forall 1 \leq i \leq m - 1, F^{n-2i+1}(x) \in A_1 + \mathbb{Z},$$

$$F^{n-2m+1}(x) \in A'_2 + \mathbb{Z} \quad \text{and, if } n \text{ is odd, } F(x) \in A_1 + \mathbb{Z}.$$

Thus  $x$  is periodic  $\pmod{1}$  for  $F$  and its period divides  $n$ . Since the intervals  $A_1, A_2, D'$  are disjoint  $\pmod{1}$ , one can show that its period  $\pmod{1}$  is exactly  $n$ . Indeed, consider  $1 < d < n$ .

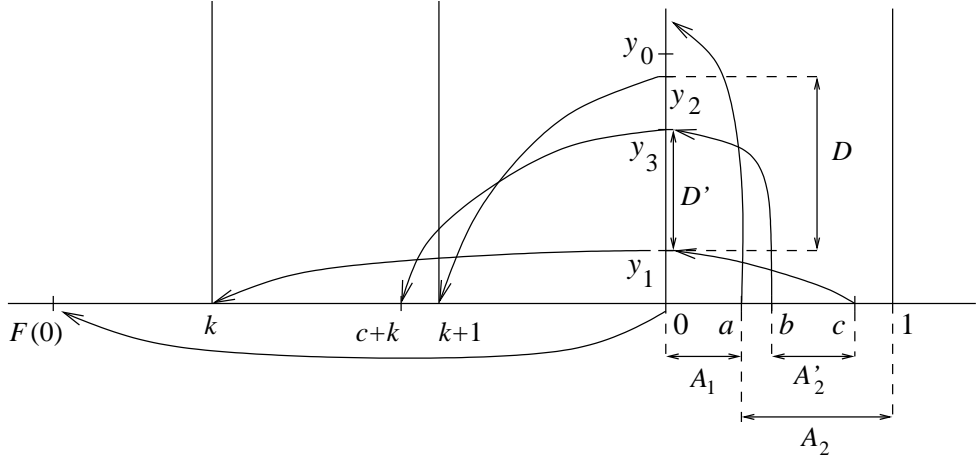

FIGURE 5. Positions of the different points in Case 1, where  $k = \lceil F(0) \rceil$  (the figure is drawn with  $q = 0$ ).

Then  $F^{n-2m+1}(x) \in A'_2 + \mathbb{Z}$  and  $F^{n-2m+1+d}(x)$  belongs to, either  $A_1 + \mathbb{Z}$ , or  $D' + \mathbb{Z}$ , and thus the period (mod 1) of  $x$  is not  $d$ .

The second case (i.e. when  $A_2 \rightarrow A_1$ ) is similar: there exist  $c \in (0, a)$ ,  $y_3 \in (y_1, y_2)$  and  $c \in (b, a)$  such that  $F(c) = y_1 \pmod{1}$ ,  $F(y_3) = c \pmod{1}$  and  $F(b) = y_3 \pmod{1}$ . If we let  $A'_1 = [c, b]$  and  $D' = [y_1, y_3]$ , then we have the covering graph shown on the right picture of Figure 4 by replacing  $A_1$  and  $D$  by  $A'_1$  and  $D'$ , respectively. The rest of the proof is the same as before by interchanging the roles of  $A_1, A_2$ . Therefore,  $F$  has periodic (mod 1) points of period  $n$  for all  $n \geq 2$ .

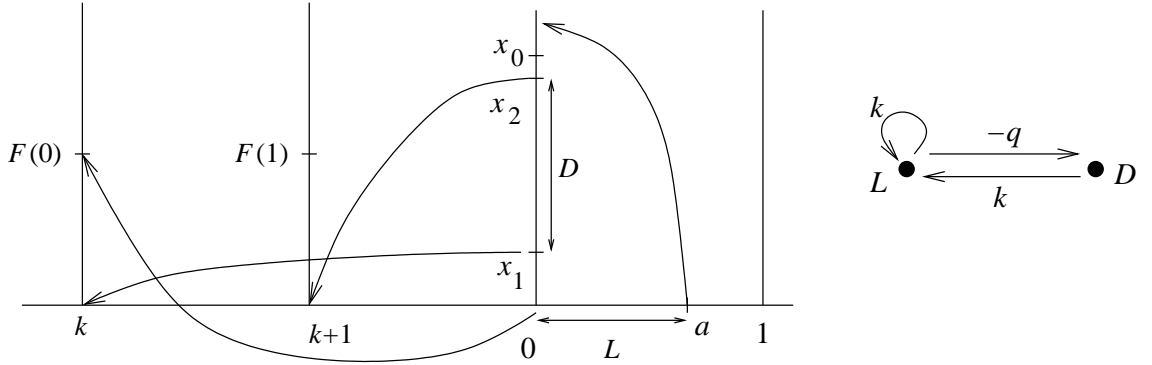

FIGURE 6. Left side: positions of the different points in Case 2, where  $k = \lceil F(0) \rceil$  and  $k < -q$  (the figure is drawn with  $q = 0$ ). Right side: the covering graph in Case 2 (both when  $k \geq -q$  and  $k < -q$ ).

**Case 2:**  $F(0) \in B$ .

Let  $k = r(F(0)) \in \mathbb{Z}$  (that is,  $F(0) \in B_k$  and  $F(1) \in B_{k+1}$ ). Observe that the set  $F([0, 1])$  contains the points  $F(a), F(0), F(1)$ , with  $F(a) \in B_{-q}$  and  $F(a) + q \geq y_0$ . When  $k \geq -q$ , we set  $L = [a, 1]$ . Then,

$$F(L) \supset \langle F(a), F(1) \rangle \supset \langle y_0 - q, k + 1 \rangle \supset \langle y_0 - q, -q \rangle \cup \langle k, k + 1 \rangle \supset (D - q) \cup (L + k).$$

When  $k < -q$ , we set  $L = [0, a]$  (see Figure 6). Then,

$$F(L) \supset \langle F(0), F(a) \rangle \supset \langle k, y_0 - q \rangle \supset \langle k, k + 1 \rangle \cup \langle -q, y_0 - q \rangle \supset (D - q) \cup (L + k).$$

Observe that, in both cases,  $F(D) \supset [0, 1] + k \supset L + k$  and, hence,  $F$  has the covering graph on the right side of Figure 6. Thus,  $\text{Per}(F) = \mathbb{N}$  by Lemma 3.9.  $\square$

*Proof of Lemma 6.4.* We set  $E_0 := \mathbb{R}$  and  $E_i := F(E_{i-1})$  for  $i \geq 1$ . Since  $F(\mathbb{R}) \supset \mathbb{R}$ ,  $E_i$  is a non-decreasing sequence of closed connected subsets of  $S$ . Thus,  $E_i \cap B_0$  is a closed subinterval of  $B_0$  containing 0.

The sets  $E_i$  are periodic (mod 1), i.e.  $E_i = E_i + k$  for every  $i \in \mathbb{N}$  and  $k \in \mathbb{Z}$ . Indeed,  $E_0$  is clearly periodic (mod 1). If  $E_i = E_i + k$  for some  $i \in \mathbb{N}$  and every  $k \in \mathbb{Z}$ , then

$$E_i = F(E_i) = F(E_i + k) = F(E_i) + k = E_{i+1} + k.$$

We claim that there exists  $n \in \mathbb{N}$  such that  $\max r(F(E_n \cap B_0)) \geq 1$ . To prove the claim set  $\mathbb{R}_{<1} := \{x \in S : r(x) < 1\} = (-\infty, 1) \cup \bigcup_{k \leq 0} B_k$  and assume that  $r(F(E_i \cap B_0)) < 1$  for every  $i \in \mathbb{N}$ . By Lemma 3.1(a) and assumption (a),

$$F(E_i \cap \mathbb{R}_{<1}) \subset E_{i+1} \cap \mathbb{R}_{<1}$$

for every  $i \in \mathbb{N}$ . Consequently,

$$F^i(E_0 \cap \mathbb{R}_{<1}) \subset E_i \cap \mathbb{R}_{<1} \subset \mathbb{R}_{<1}$$

for every  $i \in \mathbb{N}$ . Thus, for all  $x \in (-\infty, 1) = E_0 \cap \mathbb{R}_{<1}$ ,  $\rho(x) \leq 0$ . Since  $\rho_F(x+k) = \rho_F(x)$  for every  $x \in S$  and  $k \in \mathbb{Z}$  we get that  $\rho_F(x) \leq 0$  for every  $x \in \mathbb{R}$ ; a contradiction with assumption (b). This proves the claim.

Let  $n \in \mathbb{N}$  be the smallest integer such that  $\max r(F(E_n \cap B_0)) \geq 1$ .

Observe that the continuity of  $F$  and the assumption (a) imply that  $r(F(0)) \leq 0$  (in particular  $r(F(E_0 \cap B_0)) < 1$ ). Hence,  $n \geq 1$ . If  $n = 1$  then Lemma 6.3 applies and we have  $\text{Per}(F) \supset \mathbb{N} \setminus \{1\}$ .

So, in the rest of the proof we assume  $n \geq 2$ . Since  $E_n \cap B_0$  is a closed subinterval of  $B_0$  containing 0, and  $r(F(0)) \leq 0$ , the continuity of  $F$  implies that there exists  $y \in E_n \cap \mathring{B}_0$  such that  $F(y) = 1$ . By the minimality of  $n$ ,  $y \notin E_{n-1}$ .

Let  $\bar{x} \in E_{n-1}$  be such that  $F(\bar{x}) = \max E_n \cap B_0 \geq y$ . If  $\bar{x} \in E_{n-2}$  then  $E_{n-1} \cap B_0 \supset [0, F(\bar{x})] \ni y$ ; a contradiction. Consequently,  $\bar{x} \in \mathring{B}_k$  for some  $k \in \mathbb{Z}$  because  $\mathbb{R} \subset E_{n-2}$ . Set  $x = \bar{x} - k \in E_{n-1} \cap \mathring{B}_0$ . If  $x \geq y$  then the connectedness of  $E_{n-1}$  implies that  $y \in E_{n-1}$ ; a contradiction. Hence,  $x < y$ . On the other hand,  $F_0(x) = F(\bar{x}) \geq y$  and  $F(x) = F(\bar{x}) - k \in B_{-k}$ . In particular  $r(F(x)) \in \mathbb{Z}$ . The minimality of  $n$  and the fact that  $x \in E_{n-1} \cap B_0$  implies that  $r(F(x)) < 1$  and, hence,  $r(F(x)) \leq 0$ . Therefore,  $|r(F(x)) - r(F(y))| = r(F(y)) - r(F(x)) = 1 - r(F(x)) \geq 1$ . Then the lemma follows from Lemma 5.2.  $\square$

*Proof of Lemma 6.5.* If  $u \in F(\mathbb{R})$  then we are done by taking  $y = u$ . So, in what follows we assume that  $u \notin F(\mathbb{R})$ . Then, since  $z \in \mathbb{R}$  and  $u \in \text{Orb}(z, F)$  there exists  $\bar{z} \in \text{Orb}(z, F) \cap F(\mathbb{R})$  and  $l \geq 1$  such that

$$(6.1) \quad F^l(\bar{z}) = u \text{ and } F^i(\bar{z}) \notin F(\mathbb{R}) \text{ for } i = 1, 2, \dots, l.$$

Since  $F(\bar{z}) \notin F(\mathbb{R})$ ,  $\bar{z} \notin \mathbb{R}$ . Also, since  $F(\mathbb{R}) \supset \mathbb{R}$ ,  $F^i(\bar{z}) \in \bigcup_{j \in \mathbb{Z}} \mathring{B}_j$  for  $i = 1, 2, \dots, l$ . Notice that  $\bar{z} - r(\bar{z}), u - r(u) \in \mathring{B}_0$  and  $0 < \bar{z} - r(\bar{z}) < u - r(u)$ . Otherwise,  $\bar{z} - r(\bar{z}) \geq u - r(u)$  and, since  $F(\mathbb{R})$  contains  $\mathbb{R} \cup \{\bar{z}\}$  and is connected, we obtain  $F(\mathbb{R}) \supset (0, \bar{z} - r(\bar{z})) + \mathbb{Z} \ni u$ ; a contradiction.

If  $r(F(u)) - r(u) = r(F(\bar{z})) - r(\bar{z})$ , then we set  $y = \bar{z}$  and the lemma follows.

So, in the rest of the proof, we set  $\tilde{z} := \bar{z} - r(\bar{z}) \in \mathring{B}_0 \cap F(\mathbb{R})$  and we assume that

$$r(F(\tilde{z})) = r(F(\bar{z})) - r(\bar{z}) \neq r(F(u)) - r(u).$$

By Lemma 5.4(b) and the fact that  $F_0$  has degree 0,  $F^i(\bar{z}) - F_0^i(\tilde{z}) \in \mathbb{Z}$  for  $i = 0, 1, 2, \dots, l$ . Consequently,  $F_0^i(\tilde{z}) \in \mathring{B}_0$  and

$$(6.2) \quad F^i(\bar{z}) = F_0^i(\tilde{z}) + r(F^i(\bar{z}))$$

for  $i = 0, 1, 2, \dots, l$ . In particular  $u = F^l(\bar{z}) = F_0^l(\tilde{z}) + r(u)$ . Hence  $F_0^l(\tilde{z}) = u - r(u) > \tilde{z}$  and, hence,

$$(6.3) \quad \text{there exists } p \in \{0, 1, 2, \dots, l-1\} \text{ such that } F_0^p(\tilde{z}) < u - r(u) \leq F_0^{p+1}(\tilde{z}).$$

If  $r(F(F_0^p(\tilde{z}))) \neq r(F(u)) - r(u)$ , then we set  $x = F_0^p(\tilde{z})$  and  $y = u$  and the lemma follows.

Otherwise, we set  $l_1 := p < l$  and  $u_1 := F^p(\bar{z}) \in \text{Orb}(z, F) \setminus \mathbb{R}$  and from (6.2) and Lemma 3.1(a) we obtain

$$\begin{aligned} u - r(u) &> F_0^p(\tilde{z}) = u_1 - r(u_1) \text{ and} \\ r(F(u)) - r(u) &= r(F(F_0^p(\tilde{z}))) = r(F(F_0^p(\tilde{z}) + r(u_1))) - r(u_1) \\ &= r(F(u_1)) - r(u_1). \end{aligned}$$

As in (6.3), the first of the above inequalities implies that there exists  $p_1 \in \{0, \dots, p-1\}$  such that

$$F_0^{p_1}(\tilde{z}) < u_1 - r(u_1) \leq F_0^{p_1+1}(\tilde{z}).$$

If  $l_i = p = 0$  then  $u_1 = \bar{z}$ ,  $\tilde{z} = u_1 - r(u_1)$  and, hence,  $r(F(\tilde{z})) = r(F(u_1)) - r(u_1)$ . This contradicts the fact that  $r(F(\tilde{z})) \neq r(F(u)) - r(u)$ . Consequently,  $l_1 = p > 0$  and  $u_1 \notin F(\mathbb{R})$  according to (6.1). As above, this implies that  $u_1 - r(u_1) > \tilde{z}$ . So we can replace  $u$  by  $u_1$  and  $l$  by  $l_1$  without modifying the current assumptions and we can repeat iteratively the above process to obtain a sequence  $0 < l_m < l_{m-1} < \dots < l_1 < l$  with  $1 \leq m < l$  and  $p_m \in \{0, 1, 2, \dots, l_m - 1\}$  such that

- $u_i := F^{l_i}(\bar{z}) \in \text{Orb}(z, F) \setminus \mathbb{R}$  and  $r(F(u)) - r(u) = r(F(u_i)) - r(u_i)$  for  $i = 1, 2, \dots, m$ ;
- $u - r(u) > u_1 - r(u_1) > u_2 - r(u_2) > \dots > u_m - r(u_m) > \tilde{z}$ ;
- $F_0^{p_m}(\tilde{z}) < u_m - r(u_m) \leq F_0^{p_m+1}(\tilde{z})$  and  $r(F(F_0^{p_m}(\tilde{z}))) \neq r(F(u_m)) - r(u_m)$ .

Notice that such a sequence exists because we are in the case when  $r(F(\tilde{z})) \neq r(F(u)) - r(u)$ . Then the lemma follows by taking  $x = F_0^{p_m}(\tilde{z})$  and  $y = u_m$ .  $\square$

*Proof of Lemma 6.6.* If  $u = 0$ , then  $u \in F(\mathbb{R})$  and we take  $y = u$ . From now on, we assume that  $u \in \mathring{B}_0$ . By Lemma 6.5, we know that there exists  $y \in \text{Orb}(z, F) \cap \mathring{B}_0$  verifying  $y \leq u$  and  $r(F(y)) = r(F(u))$  and such that,

- (a) either  $y \in F(\mathbb{R})$ ,
- (b) or there exists  $x \in B_0$  such that  $x < y \leq F_0(x)$  and  $m := r(F(x)) \neq r(F(y))$ .

In case (a), the lemma holds. So, assume that there exists a point  $x$  as in case (b). Observe that  $m \in \mathbb{Z}$  and  $F(y) \notin B_m$  because  $F_0(x) \notin \mathbb{R}$ . So, by Lemma 5.1, the lemma holds unless  $F(0) \in (x + m, \max B_m]$ .

Assume that  $F(0) \in (x + m, \max B_m]$ . In view of Lemma 5.2, we have again that  $\text{Per}(F) = \mathbb{N}$  unless  $|m - r(F(y))| < 1$ . Finally, if  $|m - r(F(y))| < 1$ , then  $F(y) \in (m - 1, m + 1) \setminus \{m\}$  because  $F(y) \notin B_m$ . This ends the proof of the lemma.  $\square$

**6.3. Proof of Theorem G.** The proof of Theorem G is quite long. In the rest of the section, we are going to assume that  $\text{Int}(\text{Rot}_{\mathbb{R}}(F))$  contains 0 (if it contains another integer  $m$ , we come down to 0 by considering the map  $F - m$ ). The first step consists in exhibiting a particular configuration of points. Then we shall split the proof into several cases, depending of the positions of these points.

6.3.1. *A particular configuration of points.* We proceed along the lines of the proof of [7, Lemma 3.9.1]. We first introduce some notation.

Since  $0 \in \text{Int}(\text{Rot}_{\mathbb{R}}(F))$ , there exist  $a, b \in \text{Int}(\text{Rot}_{\mathbb{R}}(F))$  such that  $a < 0 < b$ , and there exist  $x_a, x_b \in \mathbb{R}$  such that  $\rho_F(x_a) = a < 0 < b = \rho_F(x_b)$ . We may assume that  $x_b < x_a$  (by taking  $x_b - k$  instead of  $x_b$  with  $k \in \mathbb{Z}$  appropriate).

**Remark 6.7.** Since  $\rho_F(x_a) < 0$  (resp.  $\rho_F(x_b) > 0$ ), the sequence  $(r(F^n(x_a)))_{n \geq 0}$  tends to  $-\infty$  (resp.  $(r(F^n(x_b)))_{n \geq 0}$  tends to  $+\infty$ ). Thus the orbits of both points have a finite number of elements in each compact subset of  $S$ .  $\diamond$

Now we define

$$\begin{aligned} \overline{M} &:= \{F^k(x_b) : k \geq 0 \text{ and } r(F^l(x_b)) > r(F^k(x_b)) \text{ for every } l > k\}, \text{ and} \\ \underline{M} &:= \{F^k(x_a) : k \geq 0 \text{ and } r(F^l(x_a)) < r(F^k(x_a)) \text{ for every } l > k\}. \end{aligned}$$

Observe that  $\overline{M} \subset \text{Orb}(x_b, F)$  and  $\underline{M} \subset \text{Orb}(x_a, F)$ . Hence,  $\overline{M} \cap \underline{M} = \emptyset$  because  $x_a$  and  $x_b$  have different rotation numbers.

The next lemma summarises the properties of  $\overline{M}$  and  $\underline{M}$ .

**Lemma 6.8.** *The following statements hold for the sets  $\overline{M}$  and  $\underline{M}$ .*

- (a) *For every  $x \in \mathbb{R}$ ,  $\text{Card}(r^{-1}(x) \cap \overline{M}) \leq 1$  and  $\text{Card}(r^{-1}(x) \cap \underline{M}) \leq 1$ .*
- (b) *Let  $L \in \mathbb{R}$ . For every  $w \in \text{Orb}(x_b, F)$  there exists a point  $\bar{x} \in \overline{M}$  such that  $r(\bar{x}) = \min(r(\text{Orb}(w, F)) \cap [L, +\infty))$  and for every  $w' \in \text{Orb}(x_a, F)$ , there exists  $\underline{x} \in \underline{M}$  such that  $r(\underline{x}) = \max(r(\text{Orb}(w', F)) \cap (-\infty, L])$ .*
- (c)  *$\min r(\overline{M}) = \min r(\text{Orb}(x_b, F)) \leq x_b$ , and  $\max r(\underline{M}) = \max r(\text{Orb}(x_a, F)) \geq x_a$ .*
- (d)  *$\sup r(\overline{M}) = +\infty$  and  $\inf r(\underline{M}) = -\infty$ .*
- (e) *If  $x \in \overline{M}$ , there exists  $x' \in \overline{M} \cap \text{Orb}(x, F)$  such that  $r(x) < r(x') \leq r(F(x))$ . The same holds with reverse inequalities with  $x, x' \in \underline{M}$ .*
- (f) *For any  $x_0 \in \mathbb{R}$  and  $x \in \overline{M}$  with  $r(x) \leq x_0$ , there exists  $x' \in \overline{M}$  such that  $r(x) \leq r(x') \leq x_0 < r(F(x'))$ . If  $r(x') = r(x)$  then  $x' = x$ . The same holds with reverse inequalities if  $x \in \underline{M}$ .*

*Proof.* We prove the lemma for the set  $\overline{M}$ . The proofs for the set  $\underline{M}$  follow similarly.

Let  $F^k(x_b), F^l(x_b) \in \overline{M}$  with  $k < l$ . From the definition of the set  $\overline{M}$ , it follows that  $r(F^l(x_b)) > r(F^k(x_b))$ . So, (a) holds.

We have  $\lim_{n \rightarrow +\infty} r(F^n(x_b)) = +\infty$  (Remark 6.7) and thus, for every  $L \in \mathbb{R}$  and every  $w \in \text{Orb}(x_b, F)$ , the set  $r(\text{Orb}(w, F)) \cap [L, +\infty)$  contains infinitely many elements. We can define  $\xi := \min(r(\text{Orb}(w, F)) \cap [L, +\infty))$ . The set  $r^{-1}(\xi) \cap \text{Orb}(w, F)$  is finite by Remark 6.7. Thus we can define  $i := \max\{n \geq 0 : r(F^n(w)) = \xi\}$ . It follows that, for every  $j > i$ ,  $F^j(w) \notin r^{-1}(\xi)$  and hence, by the minimality of  $\xi$ ,  $r(F^j(w)) > \xi = r(F^i(w))$ . So  $F^i(w) \in \overline{M}$ . This proves (b) with  $\bar{x} = F^i(w)$ . To prove (c) we repeat the proof of (b) by choosing  $w = x_b$  and  $L \leq \min r(\text{Orb}(x_b, F))$ . Then, we obtain  $\xi = \min(r(\text{Orb}(x_b, F)))$  by the definition of  $\xi$ . Since  $\overline{M} \subset \text{Orb}(x_b, F)$  and  $\xi \in r(\overline{M})$ , this implies that  $\min r(\overline{M}) = \min r(\text{Orb}(x_b, F))$ . Moreover, it is obvious that  $\min r(\text{Orb}(x_b, F)) \leq x_b$ , and thus we obtain (c). To prove (d), it is enough to use (b) with  $L$  tending to  $+\infty$ .

Suppose that  $x \in \overline{M}$ . Consider the set  $A = \{F^i(x) : i > 0\}$ . Then  $\min A > x$  because  $x \in \overline{M}$ . Applying (b) with  $w = x$  and  $L = \min A \in \text{Orb}(x, F)$ , we see that there exists  $x' \in \overline{M}$  such that  $r(x') = \min r(A)$ . By definition of  $A$ , we have  $r(x') \leq r(F(x))$  and this gives (e).

Let  $x_0 \in \mathbb{R}$  and let  $x \in \overline{M}$  be such that  $r(x) \leq x_0$ . The set  $r(\overline{M}) \cap (-\infty, x_0]$  is non-empty because it contains  $r(x)$ . Thus there exists  $x' \in \overline{M}$  such that  $r(x')$  is equal to the maximum of this set. Clearly,  $r(x) \leq r(x') \leq x_0$ . Suppose that  $r(F(x')) \leq x_0$  and consider the set  $A = \{F^i(x') : i > 0\}$ . Then  $\min r(A) \leq x_0$  and there exists  $x'' \in \overline{M}$  with  $r(x'') = \min(r(A))$  by (b). By the definitions of  $A$  and  $\overline{M}$ , we have  $\min r(A) > x'$ . Thus the existence of  $x''$  contradicts the definition of  $x'$ , and hence  $r(F(x')) > x_0$ . If  $x' \neq x$ , then  $x' = F^i(x)$  for some  $i > 0$ , and thus  $r(x') > r(x)$  by definition of  $\overline{M}$ . This proves (f).  $\square$

Lemma 6.8(c) states that  $\min r(\overline{M}) \leq x_b < x_a \leq \max r(\underline{M})$ . So, by Lemma 6.8(d), there exist points  $z \in \overline{M}$  and  $t \in \underline{M}$  such that  $r(z) < r(t)$  and there are no points of  $r(\overline{M} \cup \underline{M})$  in the interval  $(r(z), r(t))$ . By Lemma 6.8(b), the inequality  $r(F(z)) < r(t)$  (resp.  $r(F(t)) > r(z)$ ) would contradict the definition of  $z, t$ . Hence  $r(F(t)) \leq r(z) < r(t) \leq r(F(z))$ . Let  $z' \in \overline{M}$  (resp.  $t' \in \underline{M}$ ) be given by Lemma 6.8(e) for  $x = z$  (resp.  $x = t$ ). The summary of the properties of  $z, t, z', t'$  is then:

$$(6.4) \quad \begin{aligned} r(F(t)) &\leq r(t') \leq r(z) < r(t) \leq r(z') \leq r(F(z)) \text{ and} \\ r(F(t')) &< r(t') < r(z') < r(F(z')). \end{aligned}$$

We shall keep the notations  $z, z', t, t'$  in the whole section. Moreover, without loss of generality, we assume that  $r(t) \in [0, 1)$ . The points  $z$  and  $t$  can have the following respective positions:

- (A)  $r(t) - r(z) \geq 1$ ,
- (B)  $z, t \in \mathbb{R}$  and  $t - z < 1$ ,
- (C)  $z \in \mathring{B}_0$  and  $t \in (0, 1)$ ,
- (D)  $t \in \mathring{B}_0$  and  $z \in (-1, 0)$ .

In the next three subsections, we shall consider Cases (A), (B) and (C) respectively. Case (D) follows symmetrically from Case (C).

Before dealing with these three cases, we state some lemmas which imply the existence of all periods (mod 1), except perhaps 1, when the points  $t, t', z, z'$  defined above and  $F(0)$  satisfy some simple conditions.

**Lemma 6.9.** *Suppose that  $t \in \mathbb{R}$  and  $r(F(t)) \leq t - 1$ . If either  $z' \in \mathbb{R}$  or  $r(F(0)) \geq 0$ , then  $\text{Per}(F) = \mathbb{N}$ .*

*Proof.* If  $z' \in \mathbb{R}$ , we have  $z' < r(F(z'))$  by (6.4). Let  $x$  be the point in  $z' + \mathbb{Z}$  such that  $t < x < t + 1$  (the case  $x = t$  is not possible because  $x$  and  $t$  have different rotation numbers). By Lemma 3.1(a) we also have  $x < r(F(x))$ .

When  $r(F(0)) \geq 0$  we set  $x = 1$  and, as above,  $x < r(F(x))$ . Since  $t \in \mathbb{R}$ ,  $0 \leq t < 1$ . If  $t = 0$  then,  $0 \leq r(F(t)) \leq -1$ ; a contradiction. Hence, as in the previous case,  $t < x < t + 1$ .

Thus the interval  $I = [t, x]$  is of length less than 1 and we have  $I \xrightarrow{+}_F [t - 1, x]$  and hence  $I \xrightarrow{+}_F I \cup (I - 1)$ . Then  $\text{Per}(F) = \mathbb{N}$  by Corollary 3.15.  $\square$

**Lemma 6.10.** *Suppose that  $z \in B_0$ ,  $t, t' \in \mathbb{R}$  and  $r(F(0)) \geq t$ . Then  $\text{Per}(F) = \mathbb{N}$ .*

*Proof.* The fact that  $z \in B_0$  and (6.4) imply that  $t' \leq 0 = r(z) < t$ . Let  $t'' \in t' + \mathbb{Z}$  be such that  $t'' \in (-1, 0]$ . Necessarily,  $t' \leq t''$ . Using (6.4), we obtain  $F([t'', 0]) \supset [t'', t] = [t'', 0] \cup [0, t]$  and  $F([0, t]) \supset [t', t] \supset [t'', t]$ . Since  $[t'', 0]$  and  $[0, t]$  contain no branching points in their interior, Proposition 3.8 applies to the intervals  $[t'', 0]$  and  $[0, t]$ , and  $\text{Per}(0, F) = \mathbb{N}$ . This clearly implies that  $\text{Per}(F) = \mathbb{N}$ .  $\square$

**Lemma 6.11.** *Suppose that  $z \in B_0$ ,  $t \in \mathbb{R}$  and  $|r(F(0))| \geq 1$ . Then  $\text{Per}(F) \supset \mathbb{N} \setminus \{1\}$ .*

*Proof.* The fact that  $z \in B_0$  and (6.4) imply that  $r(F(t)) \leq 0 = r(z) < t$ . First we suppose that  $r(F(0)) \geq 1$ . Then  $F([0, t]) \supset [0, 1]$  and  $F([t, 1]) \supset [0, 1]$ . Moreover, the two intervals  $[0, t]$  and  $[t, 1]$  contain no branching point in their interior. Thus Proposition 3.8 applies and  $\text{Per}(F) = \mathbb{N}$ .

Secondly we suppose that  $r(F(0)) \leq -1$ . If, for all  $x \in (-\infty, 0)$ ,  $r(F(x)) < 0$ , then Lemma 6.4 applies (with  $x_0 = x_b$ ) and  $\text{Per}(F) \supset \mathbb{N} \setminus \{1\}$ . Otherwise there exists  $x \in (-\infty, 0)$  such that  $r(F(x)) \geq 0$ . Let  $b$  be the unique point in  $x + \mathbb{Z} \cap [0, 1]$ . Thus  $b \geq x + 1$  and  $r(F(b)) \geq 1$ . Set  $I = [0, b]$ . Then  $I \xrightarrow{+}_F I \cup (I - 1)$  and  $\text{Per}(F) = \mathbb{N}$  by Corollary 3.15.  $\square$

6.3.2. *Case (A):  $r(t) - r(z) > 1$ .* This case is solved in the next lemma.

**Lemma 6.12.** *Assume that  $r(t) - r(z) \geq 1$ . Then  $\text{Per}(F) \supset \mathbb{N} \setminus \{1\}$ .*

*Proof.* We assume that  $r(F(0)) \geq 0$  and we shall use the point  $t$ . When  $r(F(0)) \leq 0$ , the proof is similar by using the point  $z$  instead of  $t$ .

By (6.4) and our assumption,

$$r(F(t)) \leq r(t') \leq r(z) \leq r(t) - 1.$$

So, when  $t \in B_0$ , then  $r(F(t)) < r(t) = 0$ . Therefore,  $t \neq 0$  because  $r(F(0)) \geq 0$ . Consequently, either  $t \in \mathring{B}_0$ , or  $t \in (0, 1)$ .

When  $t \in (0, 1)$ , we have  $r(t) = t$  and, hence,  $r(F(t)) \leq t - 1$ . Thus, the lemma follows from Lemma 6.9.

Assume now that  $t \in \mathring{B}_0$  (and, hence,  $r(F(t)) \leq r(t) - 1 = -1$ ). By Lemma 6.6 (applied with  $x_a$  and  $t$  instead of  $z$  and  $u$ ), we know that, either  $\text{Per}(F) = \mathbb{N}$ , and the lemma holds; or there exists  $y \in B_0$  verifying  $y \leq t$  and  $r(F(y)) = r(F(t))$  and such that

- either  $y \in F(\mathbb{R})$ ,
- or there exists a point  $x \in B_0$  such that  $x < y \leq F_0(x)$ ,  $F(0) \in (x + m, \max B_m]$  and  $F(y) \in (m - 1, m + 1) \setminus \{m\} \subset \mathbb{R}$ , where  $m := r(F(x)) \in \mathbb{Z}$ .

In the second case,  $m \geq 0$  because  $r(F(0)) \geq 0$ . But  $r(F(y)) = r(F(t)) \leq -1$ . Hence,  $r(F(y)) \leq m - 1$ , and thus the second case is not possible. Consequently,  $y \in F(\mathbb{R})$ . Since  $r(F(y)) \leq -1 \leq \lfloor r(F(0)) \rfloor - 1$ , we can use Lemma 6.3. Hence,  $\text{Per}(F) \supset \mathbb{N} \setminus \{1\}$  in this case.  $\square$

6.3.3. *Case (B):  $z, t \in \mathbb{R}$  and  $t - z < 1$ .* This case is dealt by the next lemma.

**Lemma 6.13.** *Assume that  $t, z \in \mathbb{R}$  and  $t - z < 1$ . Then  $\text{Per}(F) = \mathbb{N}$ .*

*Proof.* We assume that  $r(F(0)) \geq 0$  and we shall use the point  $t$ . When  $r(F(0)) \leq 0$ , the proof is similar by using the point  $z$  instead of  $t$ .

Assume first that  $z \geq 0$ . From (6.4), it follows that

$$r(F(t)) \leq z < t < r(z') \leq r(F(z)) \quad \text{and} \quad r(z') < r(F(z')).$$

Let  $I = [z, t]$ . There is no branching point in the interior of  $I$  since we have assumed  $z \geq 0$ . If  $r(F(z)) < 1$ , then  $z' \in (0, 1)$  and we set  $J = [t, z']$  (see the left part of Figure 7). If  $r(F(z)) \geq 1$ , we set  $J = [t, 1]$  (see the right part of Figure 7). In both cases, there is no branching point in  $J$ ,  $F(I) \supset I \cup J$  and  $F(J) \supset I \cup J$ . Then Proposition 3.8 applies and  $\text{Per}(0, F) = \mathbb{N}$ , and hence  $\text{Per}(F) = \mathbb{N}$ .

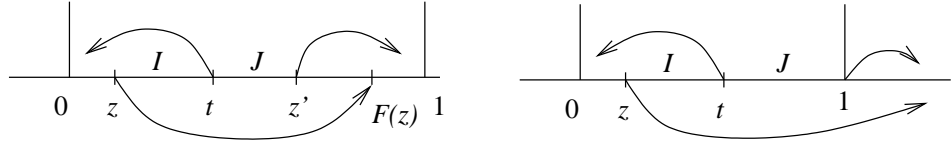

FIGURE 7. When  $z \geq 0$ , the two possible locations of the intervals  $I, J$ , forming a horseshoe in both cases.

When  $r(F(t)) \leq t - 1$ , the lemma follows from Lemma 6.9. So, in the rest of the proof we can assume that  $t - 1 < r(F(t)) \leq z < 0$ . From (6.4), it follows that

$$t - 1 < r(F(t)) \leq t' < z < 0, \quad r(F(t')) < t' \quad \text{and} \quad r(F(z)) \geq t.$$

This configuration is depicted in Figure 8. Then

$$\begin{aligned} F([t', z]) &\supset [t', t] \supset [t', z] \cup [0, t], \quad \text{and} \\ F([0, t]) &\supset [t', 0] \supset [t', z]. \end{aligned}$$

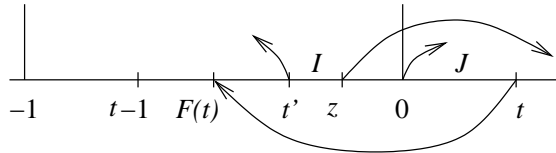

FIGURE 8. When  $t - 1 < r(F(t)) \leq z < 0$ , the intervals  $I = [t', z]$  and  $J = [0, t]$  form a horseshoe.

Since the intervals  $(t', z)$  and  $(0, t)$  contain no branching points, Proposition 3.8 applies and  $\text{Per}(F) = \mathbb{N}$ .  $\square$



6.3.4. *Case (C):*  $z \in \mathring{B}_0$  and  $t \in (0, 1)$ . We want to show that, in this situation, either  $\text{Per}(F) \supset \mathbb{N} \setminus \{1\}$  or  $\text{Per}(F) \supset \mathbb{N} \setminus \{2\}$ . This is the most difficult case. To deal with it we need some additional points.

Lemma 6.5 applied with  $z \in \text{Orb}(x_b) \setminus \mathbb{R}$  instead of  $u \in \text{Orb}(z) \setminus \mathbb{R}$  gives a point  $y$  such that  $y_0 := y - r(y) \in \mathring{B}_0$ ,  $r(F(y_0)) = r(F(y)) - r(y) = r(F(z))$  and, either

$$y \in F(\mathbb{R}),$$

(6.5) or there exists  $x \in B_0$  such that  $x < y_0 \leq F_0(x)$  and  $r(F(x)) \neq r(F(y_0))$ .

Observe that, since  $F$  has degree one,  $F(\mathbb{R})$  is periodic (mod 1) and, hence,  $y \in F(\mathbb{R})$  implies  $y_0 \in F(\mathbb{R})$ . Also,  $z \in \mathring{B}_0$  implies  $r(F(y_0)) = r(F(z)) > r(z) = 0$  by (6.4).

Let  $a \in [0, 1)$  be such that  $F_0(a) = \max(F(\mathbb{R}) \cap B_0)$ , and let  $q \in \mathbb{Z}$  be such that  $F(a) \in B_q$ . In the rest of this subsection, we shall keep the notations  $y_0, a, q$  to refer to these objects.

We are going to consider three subcases, depending on the positions of  $y_0$  and  $t'$ :

(C1)  $y_0 \notin F(\mathbb{R})$ ,

(C2)  $y_0 \in F(\mathbb{R})$  and  $t' \in B_0$ ,

(C3)  $y_0 \in F(\mathbb{R})$  and  $t' \notin B_0$ .

Cases (C1), (C2) and (C3) are respectively proved in Lemmas 6.14, 6.16 and 6.18. Altogether, they give Case (C).

**Lemma 6.14.** *If  $y_0 \notin F(\mathbb{R})$  then, either  $\text{Per}(F) \supset \mathbb{N} \setminus \{2\}$  or  $\text{Per}(F) \supset \mathbb{N} \setminus \{1\}$ .*

We first state a part of the proof as a separate lemma because it will be used again in Case (C2).

**Lemma 6.15.** *Suppose that there exist points  $w, x, y \in B_0$  and  $m \in \mathbb{Z}$  such that  $|r(F(w))| < 1$ ,  $r(F(w)) = r(F(y))$ ,  $F(x) \in B_m$ ,  $x < y \leq F_0(x)$ ,  $w \in \overline{M}$  (resp.  $w \in \underline{M}$ ) and  $m \leq 0$  (resp.  $m \geq 0$ ). Then  $\text{Per}(F) \supset \mathbb{N} \setminus \{2\}$ .*

*Proof.* We prove the lemma in the case  $w \in \overline{M}$ . The other one is symmetric. According to Lemma 6.8(e), there is a point  $w' \in \overline{M}$  such that  $r(w) < r(w') \leq r(F(w))$ . Since  $w \in B_0$  and  $|r(F(w))| < 1$ , the point  $w'$  belongs to  $(0, 1)$ . Moreover,  $r(F(w')) > w'$  because  $w' \in \overline{M}$ . Let  $I = \langle w', x \rangle$ , endowed with the order for which  $\min I = w'$ , and  $J = [x, y] \subset B_0$  (with the order of  $B_0$ ); see Figure 9. Then  $I$  positively covers  $I + m$  and  $J + m$ , and  $J$  negatively covers  $I + m$

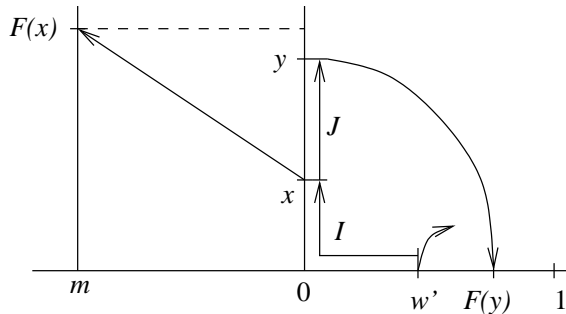

FIGURE 9. Intervals  $I$  and  $J$ , with arrows indicating their order. Though not needed in the proof, it can be noticed that the assumptions imply that  $r(F(w)) \in (0, 1)$ , and hence  $F(y) = F(w) \in (0, 1)$ .

and  $J + m$ . Moreover,  $(I + \mathbb{Z}) \cap (J + \mathbb{Z}) = \{x\} + \mathbb{Z}$ , and  $F(x) \notin I + \mathbb{Z}$ . Thus Lemma 3.16 applies and gives  $\text{Per}(F) \supset \mathbb{N} \setminus \{2\}$ .  $\square$

*Proof of Lemma 6.14.* Since  $y_0 \notin F(\mathbb{R})$ , there exists  $x \in B_0$  such that  $x < y_0 \leq F_0(x)$  and  $r(F(x)) \neq r(F(y_0))$  by (6.5). Set  $m := r(F(x)) \in \mathbb{Z}$  (thus,  $F(x) \in B_m$ ). If  $|r(F(y_0)) - m| \geq 1$  Lemma 5.2 applies and  $\text{Per}(F) = \mathbb{N}$ . Since  $r(F(y_0)) > 0$ , the condition  $|r(F(y_0)) - m| \geq 1$  is verified, in particular, when  $m \leq -1$  or  $F(y_0) \in B$ . On the other hand, if  $r(F(0)) \geq 1$ , then

$\text{Per}(F) \supset \mathbb{N} \setminus \{1\}$  by Lemma 6.11. So, in the rest of the proof we can assume that  $F(y_0) \notin B$ ,  $m \geq 0$  and  $r(F(0)) < 1$ . If  $m \geq 1$ , Lemma 5.1 gives  $\text{Per}(F) = \mathbb{N}$ . Therefore, we are left with the case  $m = 0$ ,  $F(0) \in (x, \max B_0]$  and  $r(F(y_0)) < m + 1 = 1$ . Then  $r(F(z)) = r(F(y_0)) \in (0, 1)$ , and finally Lemma 6.15, applied to  $w = z \in \dot{B}_0$ ,  $x, y = y_0$ , gives  $\text{Per}(F) \supset \mathbb{N} \setminus \{2\}$ .  $\square$

Now we study Case (C2).

**Lemma 6.16.** *Assume that  $y_0 \in F(\mathbb{R})$  and  $t' \in B_0$ . Then, either  $\text{Per}(F) \supset \mathbb{N} \setminus \{2\}$ , or  $\text{Per}(F) \supset \mathbb{N} \setminus \{1\}$ .*

Again, we state a part of the proof as a lemma, in order to use it again in Case (C3).

**Lemma 6.17.** *If there exist  $z_0, t_1, t_2 \in \mathbb{R}$  such that  $0 \leq t_1 \leq z_0 \leq t_2 \leq 1$ ,  $z_0 \in \overline{M}$  and  $t_1, t_2 \in \underline{M} + \mathbb{Z}$ , then  $\text{Per}(0, F) = \mathbb{N}$ .*

*Proof.* Let  $k_1, k_2 \in \mathbb{Z}$  be such that  $t_1 \in \underline{M} + k_1$  and  $t_2 \in \underline{M} + k_2$ . The points  $t_1, t_2$  cannot be equal to  $z_0$  because  $\rho_F(z_0) > 0$  and  $\rho_F(t_1) = \rho_F(t_2) < 0$ . According to Lemma 6.8(f) (applied with  $x_0 = z_0 - k_2$  and  $x = t_2 - k_2$ ), there exists  $t'_2 \in \underline{M} + k_2$  such that  $r(F(t'_2)) < z_0 \leq r(t'_2) \leq t_2$ . We choose this point so that  $r(t'_2)$  is minimal. Since  $0 < z_0 < t_2 \leq 1$  then, either  $t'_2$  is in  $(0, 1)$ , or  $r(t'_2) = 1 = t_2$ , in which case  $t'_2 = t_2$ . Thus  $t'_2$  is in  $(0, 1] \subset \mathbb{R}$ . Similarly, there exists  $z'_0 \in (0, 1) \cap \overline{M}$  such that  $z_0 \leq z'_0 \leq t'_2 < r(F(z'_0))$ . Since  $z'_0 \in \overline{M}$  and  $t'_2 \in \underline{M} + k_2$ ,  $z'_0 < t'_2$  because they have different rotation numbers. By Lemma 6.8(e), there exists  $t''_2 \in \underline{M} + k_2$  such that  $r(F(t''_2)) \leq t''_2 < t'_2$ . Moreover,  $t''_2 < z_0$  by the minimality of  $r(t'_2)$ . We set  $t'_1 := \max(t_1, t''_2)$ . Then  $t'_1 \in (\underline{M} + k_1) \cup (\underline{M} + k_2)$  and  $\max(t_1, r(F(t'_2))) \leq t'_1 < z_0$ . Thus  $t'_1 \in [0, 1)$  and  $r(F(t'_1)) \leq t'_1$

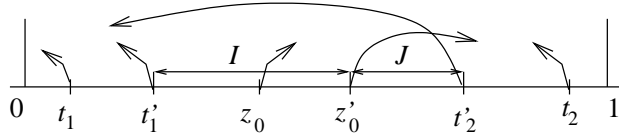

FIGURE 10. Positions of the points in Lemma 6.17; the intervals  $I = [t'_1, z'_0]$  and  $J = [z_0, t'_2]$  form a horseshoe.

because  $t'_1 \in \underline{M} + \mathbb{Z}$ . Then the points have the following positions (see Figure 10):

$$\max(r(F(t'_2)), r(F(t'_1))) \leq t'_1 < z'_0 < t'_2 < r(F(z'_0)).$$

So, Proposition 3.8 applies to the intervals  $[t'_1, z'_0]$  and  $[z'_0, t'_2]$ , and thus  $\text{Per}(0, F) = \mathbb{N}$ .  $\square$

*Proof of Lemma 6.16.* We can assume that  $r(F(0)) \in (-1, 1)$ , otherwise Lemma 6.11 gives the conclusion.

We apply Lemma 6.6 with  $z = x_a$  and  $u = t' \in \text{Orb}(x_a) \cap B_0$ , to obtain a point  $y \in B_0$  such that  $r(F(y)) = r(F(t'))$ , and:

- (i) either  $\text{Per}(F) = \mathbb{N}$  (and we are over),
- (ii) or  $y \in F(\mathbb{R})$ ,
- (iii) or there exists  $x' \in B_0$  such that  $x' < y \leq F_0(x')$  and  $F(0) \in B_{m'}$ , where  $m' := r(F(x')) \in \mathbb{Z}$  and  $F(y) \in (m' - 1, m' + 1) \setminus \{m'\}$ .

In the last case, necessarily  $m' = 0$  because we have assumed  $r(F(0)) \in (-1, 1)$ . Hence,  $r(F(t')) = r(F(y)) \in (-1, 1)$ , and we can apply Lemma 6.15 with  $w = t', x', y$  to obtain  $\text{Per}(F) \supset \mathbb{N} \setminus \{2\}$ .

From now on, we suppose that we are in case (ii), that is,  $y \in F(\mathbb{R})$ . Since we have assumed that  $y_0 \in F(\mathbb{R})$ , we have  $F_0(a) \geq \max(y, y_0)$  (in  $B_0$ ). Let  $J = \langle y, y_0 \rangle$ ; this interval is included in  $B_0$  and thus contains no branching in its interior. If, for every  $x \in (-\infty, 0)$ ,  $r(F(x)) < 0$ , then Lemma 6.4 applies (with  $x_0 = x_b$ ) and  $\text{Per}(F) \supset \mathbb{N} \setminus \{1\}$ . Otherwise, there exists a point  $x \in (-\infty, 0)$  such that  $r(F(x)) \geq 0$ . Let  $b$  be the unique point in  $(x + \mathbb{Z}) \cap [0, 1)$ . Then  $b \geq x + 1$  and  $r(F(b)) \geq 1$ . Since  $t, b \in [0, 1)$  and  $r(F(t)) \leq r(z) = 0$  by (6.4), we have  $F([0, 1]) \supset [0, 1]$ . Moreover, since  $a \in [0, 1)$  and  $F(a) \in B_q$ , we have  $F([0, 1]) \supset [0, F_0(a)] + q$  because, either

$F(0) \notin B_q$  or  $F(1) \notin B_q$ . Thus  $F([0, 1]) \supset J + q$ . On the other hand,  $F(J) \supset [r(F(y)), r(F(y_0))]$  and  $r(F(y)) = r(F(t')) \leq r(z) = 0$ . Thus, if

$$(6.6) \quad r(F(y_0)) \geq 1,$$

then  $F(J) \supset [0, 1]$  and we have the situation and the coverings represented in Figure 11. Then  $\text{Per}(F) = \mathbb{N}$  by Lemma 3.9.

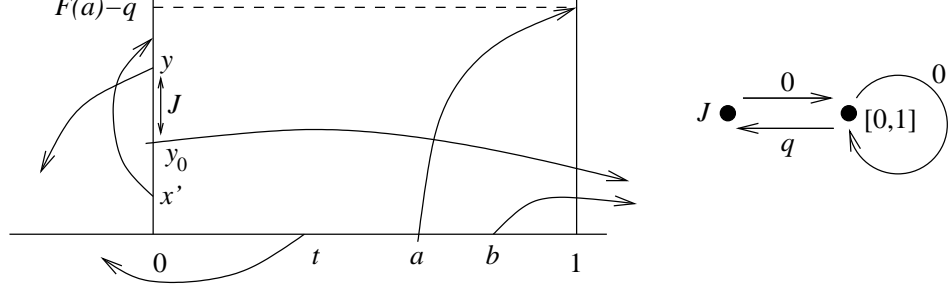

FIGURE 11. Left side: points  $t, a, b$  are in  $[0, 1]$  but maybe not in this order; point  $y$  may be below  $y_0$  in  $B_0$ . In all cases, we have the coverings on the right.

From now on, we assume that (6.6) does not hold, that is,  $r(F(y_0)) < 1$ . This implies that  $z' \in (0, 1)$  and  $r(F(y_0)) \geq z'$  by (6.4) (recall that  $r(F(y_0)) = r(F(z))$ ). If there exists  $t_2 \in (\underline{M} + 1) \cap [z', 1]$ , then Lemma 6.17 applies (with  $z_0 = z'$ ,  $t_1 = t$  and  $t_2$ ) and  $\text{Per}(F) = \mathbb{N}$ . So, in the rest of the proof we assume that

$$(6.7) \quad (\underline{M} + 1) \cap [z', 1] = \emptyset.$$

Lemma 6.8(f), applied with  $x_0 = z' - 1$  and  $x = t' \in \underline{M}$ , implies that  $r(F(t'+1)) < z'$  (otherwise, there would exist  $t'' \in \underline{M}$  such that  $z' \leq r(t'') + 1 \leq r(t') + 1$ , which would contradict (6.7) since  $r(t') + 1 \leq 1$ ). Since  $F$  has degree one,  $r(F(y)) = r(F(t')) < z' - 1$  and, hence,  $F(J) \supset [z' - 1, z']$ .

Now we split the proof of this remaining case into three subcases, depending on the values of  $a$  and  $q$ .

- If  $a \leq z'$ , we have the situation represented in Figure 12. We set  $I = [0, z']$  and there

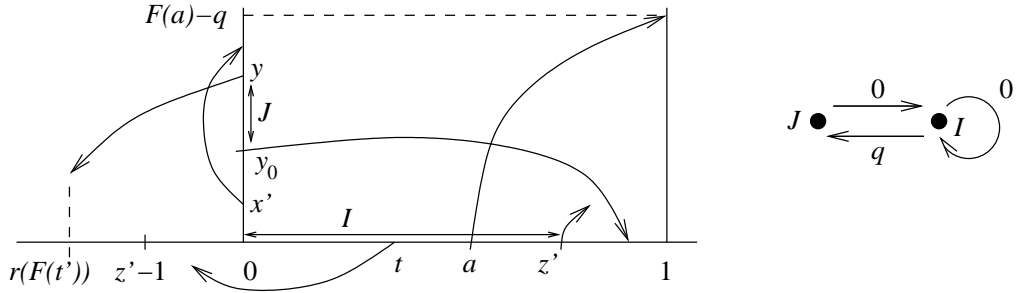

FIGURE 12. Left side: points  $t, a$  are in  $[0, z']$  but maybe not in this order; point  $y$  may be below  $y_0$  in  $B_0$ . In all cases, we have the coverings on the right.

is no branching point in  $(0, z')$  because  $z' \in (0, 1)$ . The interval  $I$  contains  $t, z'$  and  $a$ , with  $r(F(t)) \leq 0$  and  $r(F(z')) > z' > 0$ . Either  $F(t) \notin B_q$ , or  $F(z') \notin B_q$ , and thus  $F(I)$  contains  $[q, F(a)] \subset B_q$ . Hence  $I \rightarrow J + q$ . Moreover,  $I \rightarrow I$  and  $J \rightarrow I$ . Thus  $\text{Per}(F) = \mathbb{N}$  by Lemma 3.9.

- Suppose that  $a > z'$  and  $q \geq 1$ . By Lemma 6.8(e), there exists  $t'' \in \underline{M} + 1$  such that

$$(6.8) \quad r(F(t'+1)) \leq r(t'') < r(t'+1) = 1.$$

We have  $r(F(t'')) < r(t'')$  because  $t'' \in \underline{M} + 1$ . Moreover,  $r(t'') < z'$  by (6.7). We set  $\tilde{t} = \max(r(t''), t) \in (0, z')$  and, then we have  $r(F(\tilde{t})) < \tilde{t}$  (see Figure 13). Let

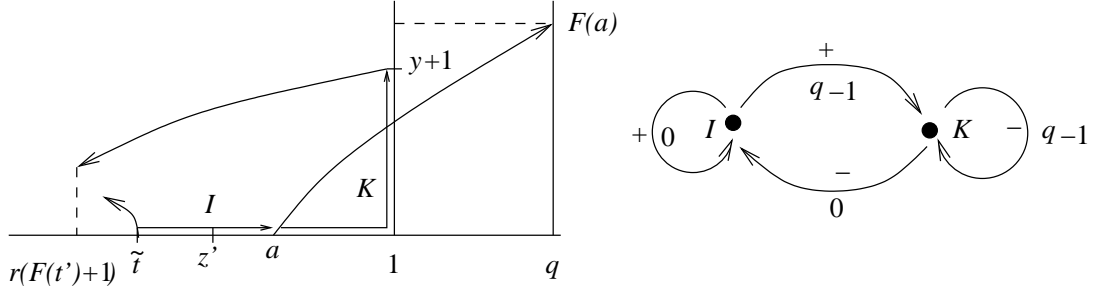

FIGURE 13. Positions of points and covering graph of  $I, K$ .

$I = [\tilde{t}, a] \subset \mathbb{R}$  and  $K = \langle a, y + 1 \rangle$  endowed with the order such that  $\min K = a$ . Then  $I$  positively covers  $I$  and  $K + q - 1$  (because  $F(a) \in B_q$  with  $q \geq 1$ ) and  $K$  negatively covers  $I$  and  $K + q - 1$  (because  $q \geq 1$  and  $r(F(y)) = r(F(t'))$  and  $r(F(t' + 1)) \leq r(t'') \leq \tilde{t}$  by (6.8)). Moreover,  $(I + \mathbb{Z}) \cap (K + \mathbb{Z}) = \{a\} + \mathbb{Z}$ , and  $F(a) \notin I + \mathbb{Z}$ . Thus Lemma 3.16 applies and gives  $\text{Per}(F) \supset \mathbb{N} \setminus \{2\}$ .

- Suppose that  $a > z'$  and  $q \leq 0$ . Let  $I = \langle a, b \rangle \subset [0, 1)$ . If  $0 \leq b \leq t$ , then  $[b, t]$  and  $[t, z']$  form a horseshoe; and if  $t \leq b \leq a$ , then  $[t, b]$  and  $I$  form a horseshoe (see Figure 14). In both cases, Proposition 3.8 applies and  $\text{Per}(F) = \mathbb{N}$ .

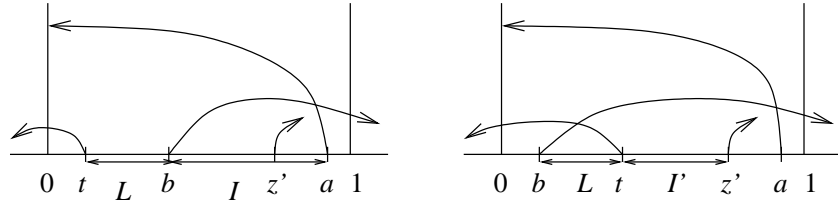

FIGURE 14. The two possibilities when  $b < z'$ . In both cases, there is a horseshoe (either  $L, I$  or  $L, I'$ ).

It remains to consider the case when  $b > a$ , which implies that  $b > z'$ ; see Figure 15. Then  $J$  covers  $I - 1$  (recall that  $r(F(y)) = r(F(t')) \leq z' - 1$ ) and  $I$  covers  $I$  and  $J + q$ .

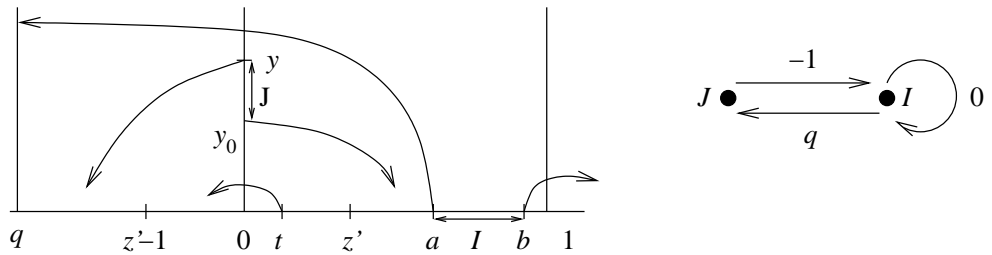

FIGURE 15. When  $b \geq a$ .

Notice that  $I \subset (0, 1)$  because  $b \geq z' > r(z) = 0$ , which implies that the sets  $I + \mathbb{Z}$  and  $J + \mathbb{Z}$  are disjoint. Then  $\text{Per}(F) = \mathbb{N}$  by Lemma 3.9

We have covered all the possible cases, and thus Lemma 6.16 is proved.  $\square$

Finally, in the next lemma we study Case (C3).

**Lemma 6.18.** *Suppose that  $y_0 \in F(\mathbb{R})$  and  $t' \notin B_0$ . Then, either  $\text{Per } F \supset \mathbb{N} \setminus \{1\}$ , or  $\text{Per } F \supset \mathbb{N} \setminus \{2\}$ .*

In order to make the proof easier to read, we first deal with a special configuration of points.

**Lemma 6.19.** *Suppose that  $y_0 \in F(\mathbb{R})$ ,  $t', z' \in \mathbb{R}$ ,  $r(F(0)) \leq t$  and  $t' + 1 \leq z' \leq a < 1$ . Then  $\text{Per}(F) \supset \mathbb{N} \setminus \{2\}$ .*

*Proof.* Let  $I := [t, z']$ ,  $J := [t', t]$  and  $K := [0, y_0]$ . Notice that these three intervals have disjoint interiors, and  $\text{Int}(J)$  contains the branching point 0 (see Figure 16).

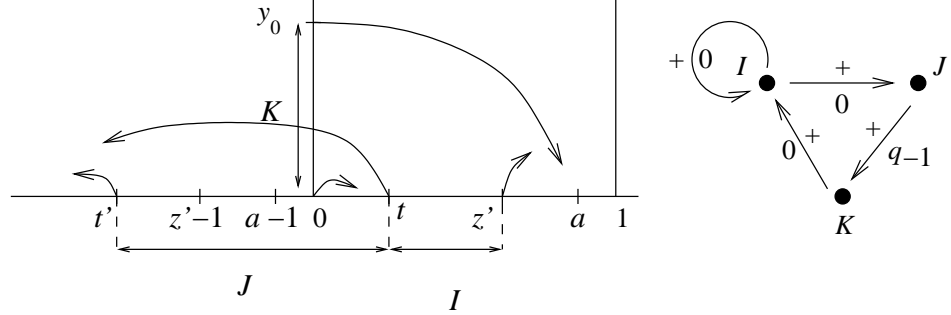

FIGURE 16. The intervals  $I, J, K$  and their covering graph in Lemma 6.19.

It is clear that  $I \xrightarrow{+}_F I$ ,  $I \xrightarrow{+}_F J$  and  $K \xrightarrow{+}_F I$ . By assumption,  $t' < z' - 1 < a - 1 < 0$ . Thus, all these points belong to  $J$ . Moreover, either  $F(t') \notin B_{q-1}$ , or  $F(z' - 1) \notin B_{q-1}$  (because  $r(F(t')) < t'$  and  $r(F(z')) > z'$ ). Hence  $J \xrightarrow{+}_F K + q - 1$ . Now, we are going to show that these coverings imply that  $\text{Per}(F) \supset \mathbb{N} \setminus \{2\}$ . We set

$$\mathcal{C} := I \xrightarrow{+}_F I \quad \text{and} \quad \mathcal{C}' := I - q + 1 \xrightarrow{+}_F J - q + 1 \xrightarrow{+}_F K \xrightarrow{+}_F I.$$

Proposition 3.14, applied to the loop  $\mathcal{C}$ , shows that there exists a fixed point. We fix  $n \geq 3$  and we consider the chain of coverings  $\mathcal{C}'\mathcal{C}^{n-3}$ . This gives a loop of length  $n$  from  $I - q + 1$  to  $I$ . According to Proposition 3.14, there exists a point  $x \in I - q + 1$  such that  $F^n(x) = x + q - 1$ ,  $F(x) \in J - q + 1$ ,  $F^2(x) \in K$  and  $F^i(x) \in I$  for all  $3 \leq i \leq n$ . It remains to prove that the period (mod 1) of  $x$  is exactly  $n$ . Let  $p$  be the period (mod 1) of  $x$ . If  $p < n$ , then  $p \leq n - 2$  because  $p$  divides  $n \geq 3$ . Thus  $F^2(x) \in K$ ,  $F^{2+p}(x) \in I$  and  $F^{2+p}(x) - F^2(x) \in \mathbb{Z}$ . But this is impossible because  $I \subset (0, 1)$ , and hence  $(I + \mathbb{Z}) \cap (K + \mathbb{Z}) = \emptyset$ . This proves that  $p = n$ . Therefore,  $\text{Per}(F) \supset \mathbb{N} \setminus \{2\}$ .  $\square$

*Proof of Lemma 6.18.* We can assume that  $r(F(0)) \in (-1, 1)$  since, otherwise, Lemma 6.11 gives the conclusion. Applying Lemma 6.3 to  $y_0$  (knowing that  $r(F(y_0)) > 0$ ), we see that, either  $\text{Per} F \supset \mathbb{N} \setminus \{1\}$ , or we are in one of the following cases:

- (I)  $F(0) \in (-1, 0) \cup B_0$  and  $F(y_0) \in (0, 1)$ ,
- (II)  $F(0) \in (0, 1)$  and  $F(y_0) \in (0, 1)$ ,
- (III)  $F(0) \in (0, 1)$  and  $r(F(y_0)) \in [1, 2)$ .

Notice that in Cases (I) and (II), we have  $z' \in (0, 1)$  because  $t < r(z') \leq r(F(y_0)) < 1$ . In addition, we can assume that  $r(F(t)) \geq t - 1$ , otherwise Lemma 6.9 gives the result (using  $z' \in \mathbb{R}$  in Cases (I) and (II), and  $r(F(0)) \geq 0$  in Case (III)). Recall that  $r(F(t)) \leq r(t') \leq r(z) = 0$ ,  $t \in (0, 1)$  and  $t' \notin B_0$  by assumption. Thus

$$-1 < t - 1 \leq r(F(t)) \leq r(t') < 0$$

and both points  $t'$  and  $F(t)$  belong to  $(-1, 0)$ . Now we consider several cases.

- (a) If  $r(F(0)) \geq t$ , then  $\text{Per}(F) = \mathbb{N}$  by Lemma 6.10.
- (b) Suppose that  $a < t$  and  $0 < F(0) \leq t$ . If  $q \geq 1$ , then we are in the situation depicted in Figure 17 and we can apply Proposition 3.8 to  $[a, t]$  and  $[t, 1]$ .

Now assume that  $q \leq 0$ , which implies that  $a \neq 0$ . Let  $I = [a, t]$  and  $J = [0, y_0]$ . Since  $F(1) > 1$ , there exists  $d' \in (t, 1)$  such that  $F(d') > 1$ . If  $r(z') \geq 1$  we set  $d = d'$ , otherwise  $z' \in (0, 1)$  and we set  $d = z'$ . In both cases,  $t < d < 1$  and  $r(F(d)) \geq d$ .

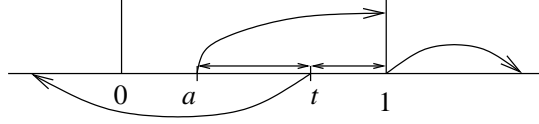

FIGURE 17. Case (b) with  $q \geq 1$  ( $q = 1$  in the picture): the intervals  $[a, t]$  and  $[t, 1]$  form a horseshoe.

Since  $r(F(t)) \leq 0 < a$ , there exists  $c \in (t, d)$  such that  $F(c) = a$ . Let  $K = [c, d]$ . Then the three intervals  $I, J, K$  contain no branching point in their interior and they are disjoint (mod 1) (that is, the sets  $I + \mathbb{Z}, J + \mathbb{Z}, K + \mathbb{Z}$  are disjoint). Moreover we have  $F(I) \supset J + q$ ,  $F(J) \supset K$  (because  $F(0) \leq t$  and  $r(F(y_0)) = r(F(z)) \geq r(z') \geq d$ ) and  $F(K) \supset I \cup K$  (see Figure 18). We define the loops of coverings

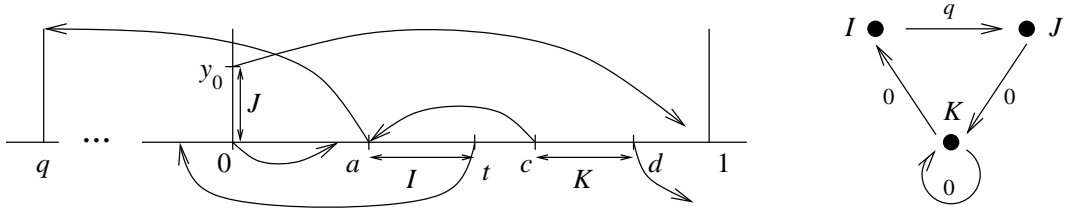

FIGURE 18. Case (b) with  $q \leq 0$ ; on the right: covering graph of  $I, J, K$ .

$$\mathcal{C} := K \longrightarrow K \quad \text{and} \quad \mathcal{C}' := K - q \longrightarrow I - q \longrightarrow J \longrightarrow K.$$

The loop  $\mathcal{C}$  gives a fixed point. For  $n \geq 3$ , we consider  $\mathcal{C}'\mathcal{C}^{n-3}$ , which is a loop of length  $n$ . According to Proposition 3.7, there exists a periodic (mod 1) point  $x \in K - q$  such that  $F^n(x) = x + q$ ,  $F(x) \in I - q$ ,  $F^2(x) \in J$  and  $F^i(x) \in K$  for all  $3 \leq i \leq n$ . It remains to prove that the period (mod 1) of  $x$  is exactly  $n$ . Let  $p$  be the period (mod 1) of  $x$ . If  $p < n$ , then  $p \leq n - 2$  because  $p$  divides  $n \geq 3$ . Thus  $F^2(x) \in J$ ,  $F^{2+p}(x) \in K$  and  $F^{2+p}(x) - F^2(x) \in \mathbb{Z}$ . But this is impossible because  $(J + \mathbb{Z}) \cap (K + \mathbb{Z}) = \emptyset$ . This proves that  $p = n$ . Therefore,  $\text{Per}(F) \supset \mathbb{N} \setminus \{2\}$ .

- (c) If  $0 < F(0) < t \leq a$  and  $r(F(y_0)) \geq 1$ , we set  $I = [t, 1]$  and  $J = [0, y_0] \subset B_0$  (see Figure 19). We have  $F(I) \supset I$  (because  $F(t) < t$  and  $F(1) > 1$ ),  $F(I) \supset J = q$  (because  $a \in I$  and  $F(1) \notin B$ ),  $F(J) \supset I$  (because  $F(0) < t$  and  $r(F(y_0)) \geq 1$  by assumption). Hence  $\text{Per}(F) = \mathbb{N}$  by Lemma 3.9.

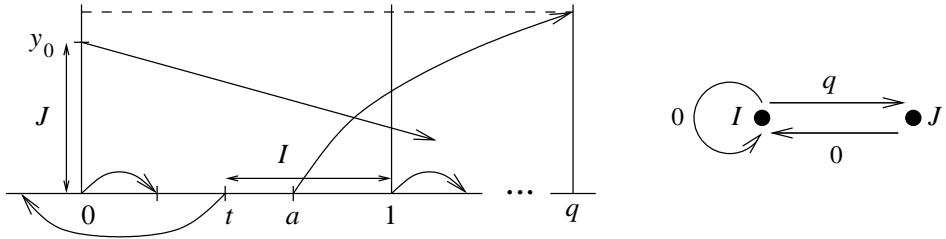

FIGURE 19. Case (c); on the right: covering graph of  $I, J$ .

- (d) If  $z' \in (0, 1)$  and  $r(F(0)) \leq t \leq a \leq z'$ , we set  $I = [t, z'] \subset \mathbb{R}$  and  $J = [0, y_0] \subset B_0$  (see Figure 20). Then  $F(J) \supset I$  (because  $r(F(0)) \leq t$  and  $r(F(y_0)) = r(F(z)) \geq z'$ ),  $F(I) \supset I$  (because  $r(F(t)) \leq t$  and  $r(F(z')) \geq z'$ ) and  $F(I) \supset J + q$  (because  $a \in I$  and either  $F(t) \notin B_q$  or  $F(z') \notin B_q$ ). Hence  $\text{Per}(F) = \mathbb{N}$  by Lemma 3.9.
- (e) Suppose that  $z' \in (0, 1)$ ,  $r(F(0)) \leq t$  and  $a > z'$ . If  $z' \leq t' + 1$ , we apply Lemma 6.17 with  $t_1 = t$ ,  $t_2 = t' + 1$ ,  $z_0 = z'$  and we obtain  $\text{Per}(F) = \mathbb{N}$ . If  $z' \geq t' + 1$ , we apply Lemma 6.19 and we obtain  $\text{Per}(F) \supset \mathbb{N} \setminus \{2\}$ .

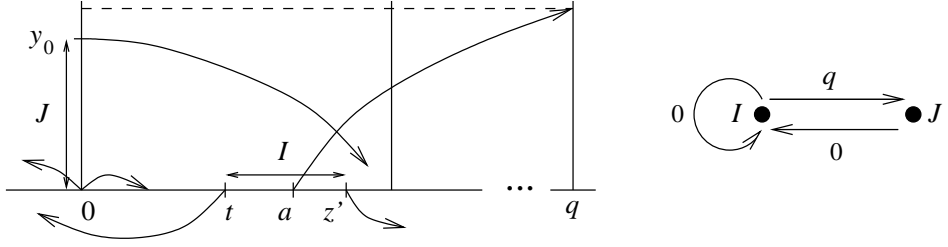

FIGURE 20. Case (d): the two arrows starting from 0 mean that it is only known that  $r(F(0)) \leq t$ ; on the left: covering graphs of  $[0, y_0]$  and  $J = [t, z']$ .

Case (III) is covered by items (a), (b) and (c). Case (II) is covered by items (a), (b), (d) and (e), and Case (I) is covered by items (d) and (e). This concludes the proof.  $\square$

6.3.5. *Conclusion of the proof.* Suppose that  $m \in \text{Int}(\text{Rot}_{\mathbb{R}}(F))$  with  $m \in \mathbb{Z}$ . We may assume that  $0 \in \text{Int}(\text{Rot}_{\mathbb{R}}(F))$  by considering  $F - m$  instead of  $F$ , which has the same set of periods. Lemmas 6.14, 6.16 and 6.18 give the conclusion in Case (C). In a similar but symmetric way Case (D) holds. This, together with Lemmas 6.12 and 6.13, gives at last Theorem G.

## 7. THE SET OF PERIODS OF ROTATION NUMBER 0 — SOME SURPRISES

For a lifting of a circle map  $F \in \mathcal{L}_1(\mathbb{R})$ , the strategy to determine  $\text{Per}(F)$  is to characterise  $\text{Per}(p/q, F)$  for every rational rotation number  $p/q$  (see [7]). The situation is different depending whether  $p/q$  belongs to the interior of the rotation interval or to its boundary. Assume that  $p, q$  are coprime. If  $p/q \in \text{Int}(\text{Rot}(F))$ , it is known that  $\text{Per}(p/q, F) = q\mathbb{N}$ . If  $p/q \in \text{Bd}(\text{Rot}(F))$ , there exists  $s \in \mathbb{N} \cup \{2^\infty\}$  such that  $\text{Per}(p/q, F) = q \cdot \text{Ssh}(s)$ . In both cases, the strategy is to prove the result for 0 (i.e.  $p/q = 0/1$ ) and then apply it to  $G := F^q - p$  to obtain the result for  $\text{Per}(p/q, F)$ . When one deals with the set of periods of a map  $F \in \mathcal{L}_1(S)$ , the first, natural idea is to adopt the same strategy and, first, (try to) characterise  $\text{Per}(0, F)$ . However, this idea does not work as expected, neither for  $\text{Per}(0, F)$ , nor for the step relating  $\text{Per}(p/q, F)$  to what can occur for 0.

The aim of this section is to show the problems that can arise for the rotation number 0. Recall that Theorem G states that, if  $0 \in \text{Int}(\text{Rot}_{\mathbb{R}}(F))$ , then  $\text{Per}(F)$  contains all integers except maybe 1 or 2. Notice that this result deals with all periods (mod 1) and not true periods. The conditions  $p/q \in \text{Int}(\text{Rot}_{\mathbb{R}}(F))$  and  $0 \in \text{Int}(\text{Rot}_{\mathbb{R}}(F^q - p))$  are equivalent; but, whereas it is straightforward to deduce  $\text{Per}(p/q, F)$  from  $\text{Per}(0, F^q - p)$ , there is no easy way to determine  $\text{Per}(F)$  when one knows  $\text{Per}(F^q - p)$ . On the other hand, Theorem D deals with a difficulty arising for rotation numbers  $p/q \in \text{Bd}(\text{Rot}_{\mathbb{R}}(F))$  when  $p/q \notin \mathbb{Z}$ .

In all examples of this section, the map  $F \in \mathcal{L}_1(S)$  will satisfy  $F(\mathbb{R}) = S$ , and hence  $\text{Rot}_{\mathbb{R}}(F) = \text{Rot}(F)$  by [8, Proposition 3.4].

**7.1.  $\text{Per}(0, F)$  when 0 is in the interior of the rotation interval.** The general rotation theory for a degree 1 map on an infinite tree states that, if  $0 \in \text{Int}(\text{Rot}_{\mathbb{R}}(F))$ , there exists  $n$  such that  $\text{Per}(0, F) \supset \{k \in \mathbb{N} : k \geq n\}$  [8, Theorem 3.11]. Unfortunately, the integer  $n$  can be arbitrarily large, even for the space  $S$ , as shown by the next example.

**Example 7.1. A map such that  $0 \in \text{Int}(\text{Rot}_{\mathbb{R}}(F))$  and  $\text{Per}(0, F) = \{k \in \mathbb{N} \mid k \geq n\}$ .**

We fix  $n \geq 3$ . Let  $b = \max B_0$  and choose  $a \in (-1, 0)$ . We define  $F \in \mathcal{L}_1(S)$  such that  $F(0) = -1$ ,  $F(b) = b + 1$ ,  $F(a) = b - n - 1$  and  $F$  is affine on  $B_0$ ,  $[-1, a]$  and  $[a, 0]$ . The map  $F$  is illustrated in Figure 21.

Using the Markov graph of  $F$  and the tools from [8, Subsection 6.1], one can compute that  $\text{Rot}_{\mathbb{R}}(F) = \text{Rot}(F) = [-(n-2), 1]$  (which contains 0 in its interior for every  $n \geq 3$ ) and  $\text{Per}(0, F) = \{k \in \mathbb{N} \mid k \geq n\}$ .  $\diamond$

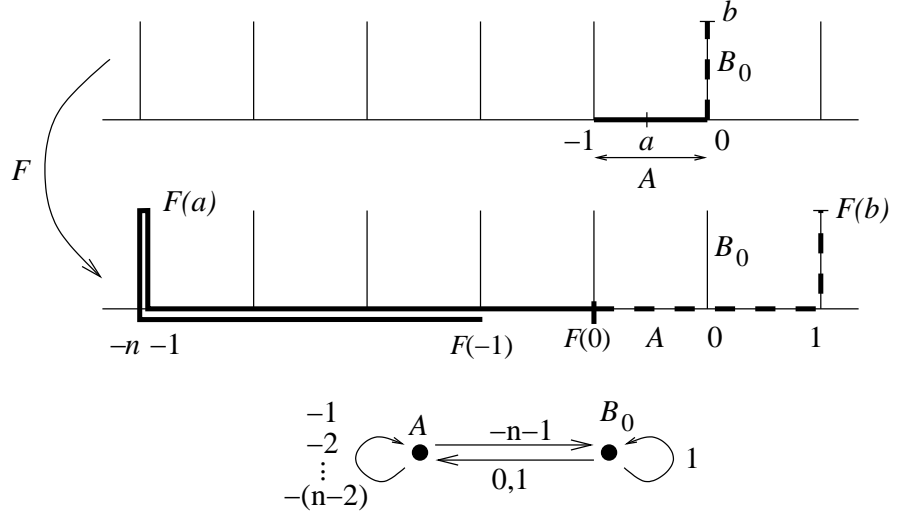

FIGURE 21. The map  $F$  of Example 7.1 and the covering graph of  $B_0$  and  $A = [-1, 0]$ . The Markov graph can be easily deduced from this graph by splitting  $A$  into  $[-1, a]$  and  $[a, 0]$ .

**7.2. Sets of periods living in complicated trees can be obtained for rotation number 0.** Although the whole space  $S$  is an infinite tree, a periodic orbit of rotation number 0 is a true periodic orbit, and thus it is compact and lives in a finite subtree of  $S$ . This makes possible to study  $\text{Per}(0, F)$  by using the works on periodic orbits for finite trees [1, 4]. In Section 4, we saw that the sets  $\text{Per}(0, F)$  can display all possible sets of periods of maps in  $\mathcal{X}_3$ . In this subsection, we show that the converse is not true: there exist maps in  $\mathcal{L}_1(S)$  with  $0 \in \text{Rot}_{\mathbb{R}}(F)$  and such that  $\text{Per}(0, F)$  is not the set of periods of a map in  $\mathcal{X}_3$ . We are going to exhibit examples in which  $\text{Per}(0, F)$  can be deduced from the set of periods of a tree map, where the tree is more complicated than a 3-star.

Let us introduce some notation. Let  $P$  be a true periodic orbit of  $F \in \mathcal{L}_1(S)$ . We will denote by  $T_P \subset S$  the finite tree defined by

$$T_P := \langle r \circ P \rangle \cup \bigcup_{i \in \langle r \circ P \rangle \cap \mathbb{Z}} B_i.$$

Observe that  $T_P$  and the closure of  $S \setminus T_P$  have at most two points in common:  $\min(r \circ P) \in \mathbb{R}$  and  $\max(r \circ P) \in \mathbb{R}$ . Moreover,  $\min(r \circ P)$  and  $\max(r \circ P)$  are either points of  $P$  or branching points.

We also define the map  $F_P: T_P \rightarrow T_P$  by  $F_P := r_{T_P} \circ F|_{T_P}$ , where  $r_{T_P}$  is the standard retraction from  $T$  to  $T_P$ . More precisely, for every  $x \in T_P$ ,

$$F_P(x) = \begin{cases} F(x) & \text{if } F(x) \in T_P, \\ \min(r \circ P) & \text{if } r(F(x)) < \min(r \circ P), \\ \max(r \circ P) & \text{if } r(F(x)) > \max(r \circ P). \end{cases}$$

Let  $x \in T_P$ . If  $F^n(x) \in T_P$  for all  $n \geq 0$ , then the orbits of  $x$  under  $F$  and  $F_P$  coincide. In particular,  $x$  is  $F$ -periodic of period  $k$  if and only if it is  $F_P$ -periodic of period  $k$ . When the orbits of  $x$  under  $F$  and  $F_P$  do not coincide it follows that  $x$  is eventually mapped by  $F_P$  either to  $\min(r \circ P)$  or  $\max(r \circ P)$ . Therefore, these are the only points that may be periodic for  $F_P$  but not for  $F$ . This leads to the next lemma, showing that it is worth studying the set of periods of  $F_P$ .

**Lemma 7.2.** *There exists  $E \subset \mathbb{N}$  with  $\#E \leq 2$  such that  $\text{Per}^\circ(F_P) \setminus E \subset \text{Per}(0, F)$ .*

Now we briefly define (in a slightly restricted case) the notions of patterns and linear models introduced in [1] to study the sets of periods of tree maps. Let  $T$  be a (finite) tree,  $P$  a finite



subset of  $T$  with at least two elements and  $\varphi$  a cyclic permutation of  $P$ . The *discrete components* of  $P$  are the sets  $\overline{C_i} \cap P, i = 1, \dots, n$ , where  $C_1, \dots, C_n$  are the connected components of  $\langle P \rangle \setminus P$ . If  $x, y$  are two distinct elements of the same discrete component,  $\langle x, y \rangle$  is called a  $P$ -*basic path*. If  $T'$  (resp.  $P, \varphi'$ ) is also a tree (resp. a finite subset of  $T'$  with at least two elements, a cyclic permutation of  $P'$ ), we write  $(T, P, \varphi) \sim_{pat} (T', P', \varphi')$  if there exists a bijection  $h: P \rightarrow P'$  such that  $h \circ \varphi = \varphi' \circ h$  and  $h$  preserves the discrete components. This gives an equivalence relation; the equivalence class of  $(T, P, \varphi)$  is denoted  $[T, P, \varphi]$  and is called a *periodic pattern*. If  $f: T \rightarrow T$  is a tree map,  $P$  a periodic orbit of  $f$  and  $A$  a periodic pattern, we say that  $f$  *exhibits*  $A$  over  $P$  if  $[T, P, f|_P] = A$ . The set of periods *forced* by a pattern  $A$  is the maximal subset  $E_A \subset \mathbb{N}$  such that every tree map exhibiting the pattern  $A$  also has periodic orbits of period  $n$  for all  $n \in E_A$ .

The triple  $(T, f, P)$  is called an  $A$ -*linear model* if

- $f$  exhibits  $A$  over  $P$ ,
- $f$  is monotone on all  $P$ -basic paths,
- for every connected component  $I$  of  $T \setminus (P \cup V(T))$  (where  $V(T)$  denotes the set of vertices of  $T$ ),  $f|_I$  is affine.

Notice that the monotonicity on  $P$ -basic paths implies that the image of each vertex  $v$  is uniquely determined and belongs to  $P \cup V(T)$  (consider three  $P$ -basic paths containing  $v$  and their images in order to find  $f(v)$  – see also [1, Proposition 4.2]). Thus an  $A$ -linear model is Markov with respect to the partition generated by  $P \cup V(T)$ . The  $A$ -linear model is the analogous of the “connect-the-dots” map associated to a periodic orbit of an interval map, but the difficulty for tree maps is that the linear model may live in a different tree than the original one — some of the vertices may collapse or explode.

The key results are the following ones. For every periodic pattern  $A$ , there exists an  $A$ -linear model (and it is unique up to isomorphism) [1, Theorem A]. Moreover, if a tree map  $f$  exhibits the periodic pattern  $A$ , then the set of periods of significant periodic points of an  $A$ -linear model is included in  $\text{Per}^\circ(f)$  [4, Corollary B]. A periodic point is called *significant* if its orbit is not equivalent, by iteration of the map, to the orbit of a vertex, see e.g. [4] for the precise definition. Significant periodic points essentially correspond to loops in the Markov graph, therefore the set of periods forced by a periodic pattern  $A$  can be computed using the Markov graph of an  $A$ -linear model.

The characterisation of the whole set of periods of a tree map uses the  $p$ -orderings of Baldwin, where  $p$  ranges in a finite set of integers depending on the tree, in particular on the valences of the vertices. When the tree is a  $k$ -star, one may need the  $p$ -orderings  $\leq_p$  for  $2 \leq p \leq k$ .

Let us come back to the map  $F_P$  coming from a periodic orbit  $P$  of  $F \in \mathcal{L}_1(S)$ . Although all the vertices of  $T_P$  have valence 3, the linear model of  $[T_P, P, F_P|_P]$  may have vertices of arbitrarily large valence. In Example 7.3, we show that, for all  $k \geq 3$ , there exist  $F \in \mathcal{L}_1(S)$  and  $P$  a periodic orbit of  $F$  such that the linear model of  $[T_P, P, F_P]$  lives in a  $k$ -star and the  $k$ -th partial ordering of Baldwin is needed to express the set of periods of  $F_P$ . More complicated trees than stars can even be obtained, as shown in Example 7.4.

**Example 7.3.** Fix an integer  $k \geq 3$ . Choose  $a \in (0, 1)$  and  $b_0, b_1, \dots, b_{k-1} \in B_0$  such that  $1 = b_0 > b_1 > \dots > b_{k-1} > 0$ . We set  $x_i = i + b_i \in B_i$  for all  $0 \leq i \leq k-1$  and  $x_k = a + k - 2 \in \mathbb{R}$ . In addition, we set

$$A_i = [b_{i+1}, b_i] \text{ for all } 0 \leq i \leq k-2, \quad A_{k-1} = [0, b_{k-1}], \quad L = [0, a] \quad \text{and} \quad R = [a, 1].$$

We define the map  $F \in \mathcal{L}_1(S)$  such that  $F(x_i) = x_{i+1}$  for all  $0 \leq i \leq k-1$ ,  $F(x_k) = x_0$ ,  $F(1) = 0$ ,  $F$  is affine in restriction to each of the intervals  $L, R$  and  $A_i, 0 \leq i \leq k-1$ , and the map is defined on the rest of  $S$  using degree 1. Then  $P = (x_0, x_1, \dots, x_k)$  is a true periodic orbit of period  $k+1$  for  $F$ , and  $F$  is linear Markov. The map  $F$  and its Markov graph are pictured in Figure 22.

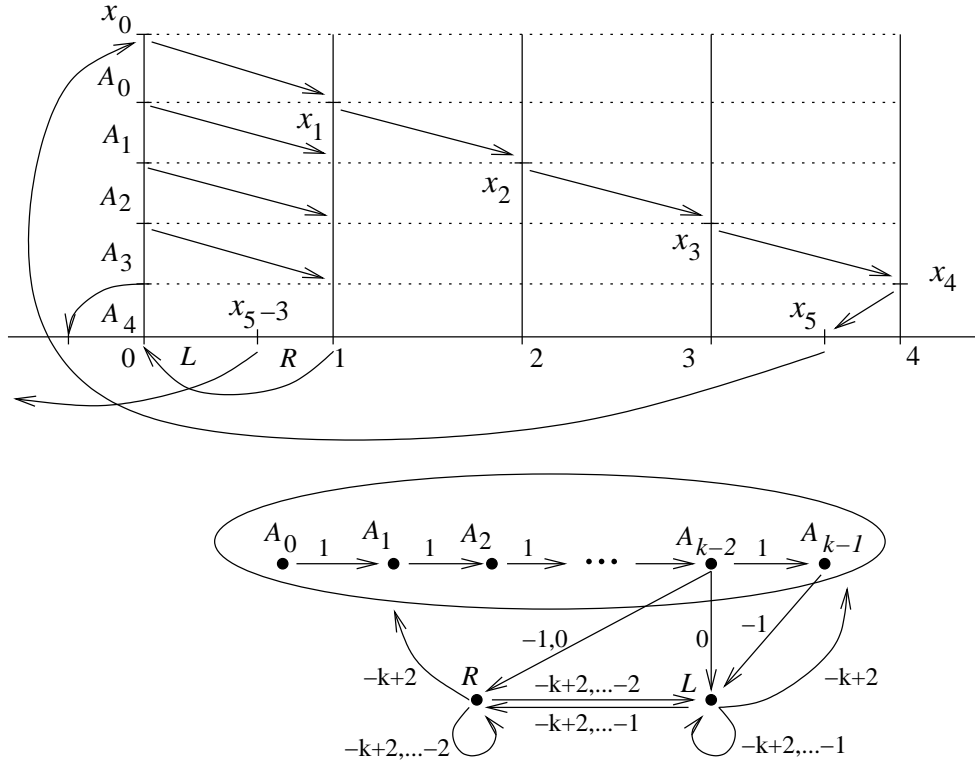

FIGURE 22. Above: the map  $F$  from Example 7.3, which is defined by its action on  $x_0, \dots, x_k$  and 1, and is piecewise linear on the partition generated by these points (mod 1); picture is for  $k = 5$ . Below: the Markov graph of  $F$ ; several integers on the same arrow, as well as an arrow pointing to the ellipse containing  $A_0, \dots, A_{k-1}$ , are short-cuts indicating several arrows.

The map  $F_P$  is defined on  $T_P = B_0 \cup \dots \cup B_{k-1} \cup [0, k-1]$ . If  $F_P(x) \neq F(x)$  then, either  $F_P(x) = k-1$ , or  $F_P(x) = 0$ . The point 0 is fixed under  $F_P$  and  $F_P^{k-1}(k-1) = 0$ . Thus  $\text{Per}^\circ(F_P) \setminus \{1\} \subset \text{Per}(0, F)$ .

The linear model of  $F_P$  is supported by a  $k$ -star; it is represented in Figure 23. To prove this fact, the easiest (but not most convincing) way is to see that the map in Figure 23 does exhibit the right pattern, then the uniqueness of the linear model gives the conclusion. We leave to the interested readers the checking that the only way to realise a linear model of  $F_P$  is to collapse the  $k-2$  vertices of  $T_P$ . This can be done by looking at all basic paths and their images.

From the linear model, one can show that the pattern  $[T_P, P, F_P|_P]$  forces all the periods  $n$  for  $n \leq_k k+1$ , where  $\leq_k$  is the  $k$ -ordering of Baldwin. A direct computation from the Markov graph of  $F$  gives  $\text{Rot}(F) = [-k+2, 0]$  and

$$\text{Per}(0, F) = \{k, k+1\} \cup \{ik + j(k+1) : i, j \geq 1\} = \{n \in \mathbb{N} : n \leq_k k+1\} \setminus \{1\}.$$

Therefore, the inclusions  $\{n \in \mathbb{N} : n \leq_k k+1\} \subset \text{Per}^\circ(F)$  and  $\text{Per}^\circ(F) \setminus \{1\} \subset \text{Per}(0, F)$  are equalities.  $\diamond$

**Example 7.4.** Given  $p, q \geq 3$ , it is possible to build a map  $G \in \mathcal{L}_1(S)$  with a true periodic orbit  $P$  of period  $p+2q-4$  such that the linear model of  $G_P$  lives in a tree consisting in a  $p$ -star glued to a  $q$ -star. To remain readable, we illustrate the construction for  $p=6$  and  $q=7$  (hence the period of  $P$  is 16) instead of giving the definition for arbitrary  $p, q$ . We choose points  $x_0 \in (0, 1)$  and  $x_1, \dots, x_{15} \in B$  as in Figure 24. Then  $G$  is defined by  $G(x_i) = x_{i+1}$  for all  $0 \leq i \leq 15$ ,  $G(x_{15}) = x_0$ ,  $G(0) = -5$  and  $G$  is of degree 1 and affine on each interval of the partition generated by these points (mod 1). We do not draw the Markov graph of  $G$ , which is rather big, but one may check that  $\text{Rot}(G) = [-5, 1]$  (in the Markov graph, the endpoints of

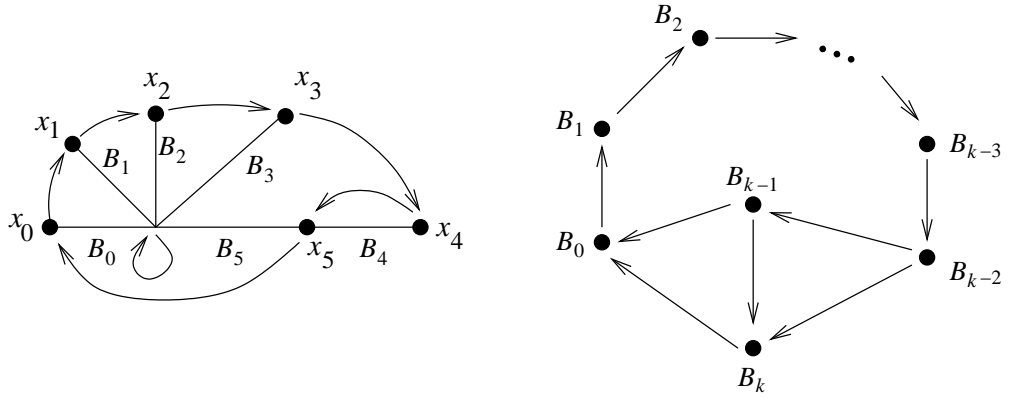

FIGURE 23. On the right: the linear model of  $[T_P, P, F_P|_P]$ , the map being affine on each of the intervals  $B_0, \dots, B_k$  (picture is with  $k = 5$ ). On the left: its Markov graph.

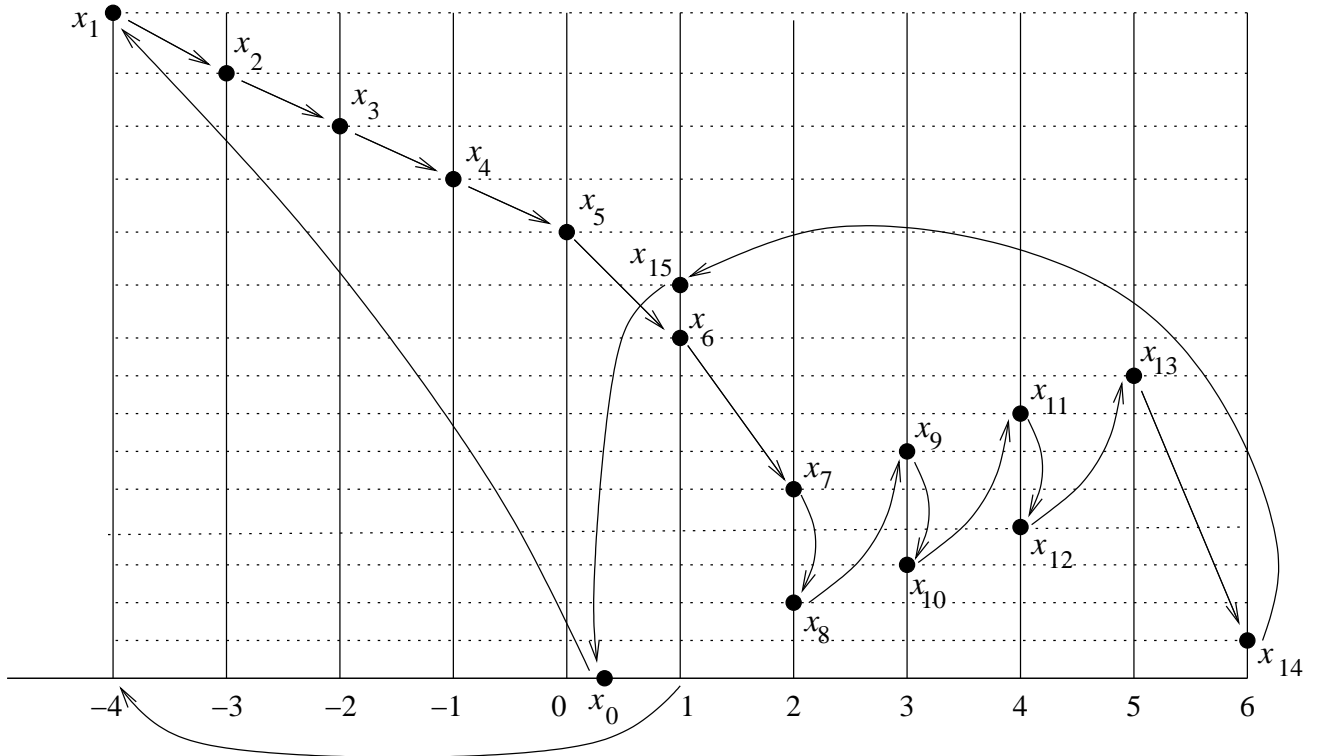

FIGURE 24. The map  $G$  from Example 7.4 and its periodic orbit  $P = \{x_0, \dots, x_{15}\}$ ;  $G$  is of degree 1 and affine on each interval of the partition generated by  $(P \cup \{0\}) + \mathbb{Z}$ .

$\text{Rot}(G)$  are reached by the loops  $[0, x_0] \xrightarrow{-5} [0, x_0]$  and, e.g.,  $[x_7 + 2, x_{12}] \xrightarrow{1} [x_7 + 2, x_{12}]$ . The tree  $T_P$  is equal to  $[-4, 6] \cup \bigcup_{-4 \leq i \leq 6} B_i$ . The point  $-4$  is fixed for  $G_P$  and the point  $6$  is sent to  $-4$  by  $G_P^2$ . Therefore, as in Example 7.3,  $\text{Per}^\circ(G_P) \setminus \{1\} \subset \text{Per}(0, G)$ . The linear model of  $G_P$  is represented in Figure 25; the  $p - 2$  vertices of  $T_P$  less than or equal to  $0$  collapse into a fixed vertex, and the  $q - 2$  vertices greater than or equal to  $1$  collapse to another fixed vertex. It is possible to compute that the set of (significant) periods of the linear model is  $\{1\} \cup \{n \geq 6\}$  and that  $\text{Per}(0, F) = \{n \geq 6\}$ .  $\diamond$

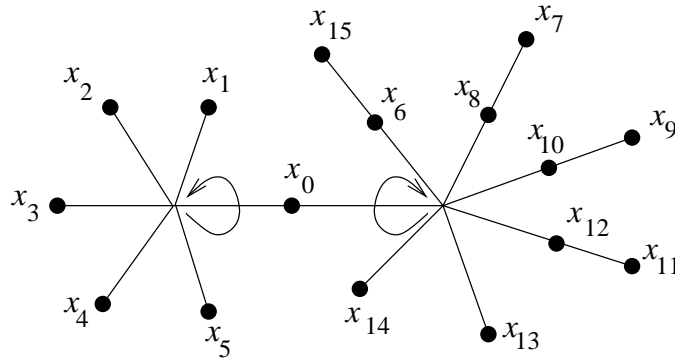

FIGURE 25. The linear model of  $G_P$  (from Example 7.4): the points  $x_0, \dots, x_{15}$  are mapped cyclically, the two vertices are fixed and the map is affine on each interval generated by this partition.

## REFERENCES

- [1] Ll. Alsedà, J. Guaschi, J. Los, F. Mañosas, and P. Mumburú. Canonical representatives for patterns of tree maps. *Topology*, 36(5):1123–1153, 1997.
- [2] Ll. Alsedà, D. Juher, and P. Mumburú. Sets of periods for piecewise monotone tree maps. *Internat. J. Bifur. Chaos Appl. Sci. Engrg.*, 13(2):311–341, 2003.
- [3] Ll. Alsedà, D. Juher, and P. Mumburú. Periodic behavior on trees. *Ergodic Theory Dynam. Systems*, 25(5):1373–1400, 2005.
- [4] Ll. Alsedà, D. Juher, and P. Mumburú. Minimal dynamics for tree maps. *Discrete Contin. Dyn. Syst.*, 20(3):511–541, 2008.
- [5] Lluís Alsedà, David Juher, and Pere Mumburú. On the preservation of combinatorial types for maps on trees. *Ann. Inst. Fourier (Grenoble)*, 55(7):2375–2398, 2005.
- [6] Lluís Alsedà, Jaume Llibre, and Michał Misiurewicz. Periodic orbits of maps of  $Y$ . *Trans. Amer. Math. Soc.*, 313(2):475–538, 1989.
- [7] Lluís Alsedà, Jaume Llibre, and Michał Misiurewicz. *Combinatorial dynamics and entropy in dimension one*, volume 5 of *Advanced Series in Nonlinear Dynamics*. World Scientific Publishing Co. Inc., River Edge, NJ, second edition, 2000.
- [8] Lluís Alsedà and Sylvie Ruelle. Rotation sets for graph maps of degree 1. *Ann. Inst. Fourier (Grenoble)*, 58(4):1233–1294, 2008.
- [9] Lluís Alsedà and Sylvie Ruelle. Periodic orbits of large diameter for circle maps. *Proc. Amer. Math. Soc.*, 138(9):3211–3217, 2010.
- [10] Stewart Baldwin. An extension of Šarkovskii’s theorem to the  $n$ -od. *Ergodic Theory Dynam. Systems*, 11(2):249–271, 1991.
- [11] Stewart Baldwin and Jaume Llibre. Periods of maps on trees with all branching points fixed. *Ergodic Theory Dynam. Systems*, 15(2):239–246, 1995.
- [12] Chris Bernhardt. Vertex maps for trees: algebra and periods of periodic orbits. *Discrete Contin. Dyn. Syst.*, 14(3):399–408, 2006.
- [13] Louis Block. Periods of periodic points of maps of the circle which have a fixed point. *Proc. Amer. Math. Soc.*, 82(3):481–486, 1981.
- [14] Louis Block, John Guckenheimer, Michał Misiurewicz, and Lai Sang Young. Periodic points and topological entropy of one-dimensional maps. In *Global theory of dynamical systems (Proc. Internat. Conf., Northwestern Univ., Evanston, Ill., 1979)*, volume 819 of *Lecture Notes in Math.*, pages 18–34. Springer, Berlin, 1980.
- [15] Ryuichi Ito. Rotation sets are closed. *Math. Proc. Cambridge Philos. Soc.*, 89(1):107–111, 1981.
- [16] M. Carme Leseduarte and Jaume Llibre. On the set of periods for  $\sigma$  maps. *Trans. Amer. Math. Soc.*, 347(12):4899–4942, 1995.
- [17] Jaume Llibre, José Paraños, and J. Ángel Rodríguez. Periods for continuous self-maps of the figure-eight space. *Internat. J. Bifur. Chaos Appl. Sci. Engrg.*, 13(7):1743–1754, 2003. On the extension of Sharkovskii’s theorem to connected graphs with non-positive Euler characteristic. In *Proceedings of the Conference “Thirty Years after Sharkovskii’s Theorem: New Perspectives” (Murcia, 1994)*, volume 5, pages 1395–1405, 1995.

- [18] Alba Málaga. Dinámica de grafos de un ciclo para funciones de grado diferente de uno (Spanish). Master thesis, Universidad Nacional de Ingeniería, Peru, 2011. Available at [http://cybertesis.uni.edu.pe/bitstream/uni/277/1/malaga\\_sa.pdf](http://cybertesis.uni.edu.pe/bitstream/uni/277/1/malaga_sa.pdf).
- [19] Michał Misiurewicz. Periodic points of maps of degree one of a circle. *Ergodic Theory Dynamical Systems*, 2(2):221–227 (1983), 1982.
- [20] O. M. Šarkovs'kiĭ. Co-existence of cycles of a continuous mapping of the line into itself. *Ukrain. Mat. Ž.*, 16:61–71, 1964.
- [21] A. N. Sharkovskii. Coexistence of cycles of a continuous map of the line into itself. In *Proceedings of the Conference “Thirty Years after Sharkovskii’s Theorem: New Perspectives” (Murcia, 1994)*, volume 5, pages 1263–1273, 1995. Translated from the Russian [Ukrain. Mat. Zh. **16** (1964), no. 1, 61–71; MR0159905 (28 #3121)] by J. Tolosa.
- [22] P. Štefan. A theorem of Šarkovskii on the existence of periodic orbits of continuous endomorphisms of the real line. *Comm. Math. Phys.*, 54(3):237–248, 1977.

DEPARTAMENT DE MATEMÀTIQUES, EDIFICI CC, UNIVERSITAT AUTÒNOMA DE BARCELONA, 08913 Cerdanyola del Vallès, BARCELONA, SPAIN  
*E-mail address:* `alseda@mat.uab.cat`

LABORATOIRE DE MATHÉMATIQUES, CNRS UMR 8628, BÂTIMENT 425, UNIVERSITÉ PARIS-SUD 11, 91405 ORSAY CEDEX, FRANCE  
*E-mail address:* `sylvie.ruette@math.u-psud.fr`