

LA-4756

UC-41

ISSUED: December 1971

CONF-710817-



Los Alamos
scientific laboratory
of the University of California
LOS ALAMOS, NEW MEXICO 87544

Proceedings of Environmental Plutonium Symposium

Held at LASL, August 4-5, 1971

by

Eric B. Fowler
Richard W. Henderson
Morris F. Milligan

NOTICE

This report was prepared as an account of work sponsored by the United States Government. Neither the United States nor the United States Atomic Energy Commission, nor any of their employees, nor any of their contractors, subcontractors, or their employees, makes any warranty, express or implied, or assumes any legal liability or responsibility for the accuracy, completeness or usefulness of any information, apparatus, product or process disclosed, or represents that its use would not infringe privately owned rights.

DISTRIBUTION OF THIS DOCUMENT IS UNLIMITED

**PROCEEDINGS OF
ENVIRONMENTAL PLUTONIUM SYMPOSIUM**

held at the

Los Alamos Scientific Laboratory
of the
University of California
Los Alamos, New Mexico

August 4 and 5, 1971

FOREWORD

The purpose of this symposium was to discuss the distribution and measurement of plutonium in the environment. To this end, the subject matter has been divided into three broad categories, the first dealing with distribution or how plutonium has entered the environment, the second dealing with methodology or the means by which one obtains environmental samples and analyzes them, and the third with the results obtained from such measurements and the interpretation which can be inferred from them.

Eric B. Fowler
Richard W. Henderson
Morris F. Milligan

Cochairmen

WELCOMING REMARKS

by

Harold M. Agnew,
Director, LASL

I am delighted to welcome you all here this morning. When we first talked about the possibility of having this meeting, it was thought that there might be twenty or thirty people who would be interested and would come out for the kick-off symposium on this particular subject. As you can see, attendance has escalated in an exponential fashion. As you are aware, we've been involved here at Los Alamos with plutonium for a long, long time. In the beginning the plutonium as a nitrate came from Hanford. We had the task of putting it in metallic form and developing the metallurgy. As you are aware, the first weapons were actually fabricated here. The basic plutonium chemistry and metallurgy had to be developed and carried out. We had a very large building called "D" Building which we have somehow environmentally, I hope, disposed of - I sometimes wonder how we ever did what we did then. I have a feeling it wouldn't pass today. I certainly know that, when one thinks of the experiments we used to do, not only in Nevada and the Pacific but right here, take the RaLa work in particular, I believe we wouldn't have a snowball's chance in hell of doing the things we used to do - and we thought we were being very prudent, being very careful - and, of course, since we lived here, had a personal stake in what we did.

I think we took all possible, at least in the context of those days twenty or twenty-five years ago, prudent precautions. As those of you who are now in the business are fully aware, we are today in a completely new ball park. I think it is probably justified. Sometimes, however, we have a feeling that people are going a little bit overboard in the publicity, and types of hysteria that goes with certain types of publicity, perhaps more to get attention than to express legitimate concern in a technical or medical sense. But nevertheless, we are very concerned, as I mentioned, not only because of the overall impact on the environment, but because we actually live here. You will probably find more Sierra Club members in fact or in spirit, per you name it, in Los Alamos than any other city or institution in the United States. So we are personally very much involved. Our friends from Rocky Flats, whom I see here, many of whom came from here, and were here in the original days - Bill Bright, and Ed Walko, and many of the other people who left here - know what I mean. They went to the Flats and we all know the problems that they've had with their plutonium in the environment. I think it behooves us all to do the very best we can in an objective manner. The problems that are facing us today are probably nothing compared with the problems we are going to be faced with ten, twenty, thirty, fifty years from now. There is no question that nuclear power, not only ordinary fission reactors but the liquid metal or other type of fast breeders, are going to be a reality. We are going to have all sorts of problems with regard to the disposal of radioactive wastes, low-level plutonium, and fission products. Someday, hopefully, the fusion projects will come into being. Maybe optimistically it will be thirty years from now that we will really have an on-line prototype fusion electrical power unit. In the meantime, and even long beyond that, we are going to be faced with problems of materials such as plutonium. I believe that the work and interest you people are involved in at a symposium such as this are going to lend to, let's say, an objective, rational approach that the leaders of the country can follow. In this manner I believe that the people in the country who are concerned will recognize the use of plutonium as being in their best interest and not being carried out just for the pleasure of some "white coated" scientists who really don't understand the problem.

Again, I am delighted to have you all here and am looking forward to seeing you this evening. My best wishes for a very successful meeting. Thank you.

PLUTONIUM DISTRIBUTION AS A PROBLEM IN ENVIRONMENTAL SCIENCE

by

W. H. Langham
Biomedical Research Group
University of California
Los Alamos Scientific Laboratory
Los Alamos, New Mexico

ABSTRACT

The potential uses of plutonium in future peace-time technology are numerous and if realized will result in a production rate of thousands of kg. per year by the end of the century. By the year 2000 it is predicted that plutonium may be producing 50% of the country's total energy needs, 3 times the amount of electrical energy now produced from coal, gas, oil, hydro, and nuclear energy altogether. Power sources for mechanical hearts and heart pacers alone will require large quantities of ^{238}Pu , as will thermoelectric generators for deep-space missions, space platforms, and communications satellites. The technology of plutonium production and processing is already established. Whether plutonium attains its predicted role in the future power economy may depend entirely on whether economically competitive methods of preventing its distribution in the environment can be attained. Repetition of the mercury situation cannot be tolerated although, in some ways, plutonium (by its chemical nature) is not as devious as mercury as a potential general environmental contaminant. Because of its solubility and other characteristics, it is not readily taken into the ecological chain. No natural bacterial or other environmental entity has been observed that converts plutonium to a solubilized form that readily enters the ecological cycle; however, this possibility is worthy of further investigation. Control of plutonium as an environmental contaminant involves control of distribution from production reactors, processing plants, storage sites, and inadvertent releases during transportation and use. An all important factor in the alleviation of plutonium distribution as a problem in environmental science is continuous surveillance with sensitive and standardized methods of monitoring not only operational discharges but environmental distribution as well, which is the theme of this conference.

Introduction

In his welcoming remarks, Dr. Harold Agnew, the ASL Director, mentioned the fact that the problems we face in dealing with radioactive contamination of our environment are considerably smaller today than they will be in the next two or three decades. There is no better way of emphasizing his remarks than to refer to Table I, developed from a talk entitled "The Plutonium Economy of the Future," given by Dr. G. T. Seaborg at the Fourth

International Conference on Plutonium and Other Actinides on October 5, 1970, in Santa Fe, New Mexico. Dr. Seaborg's projections were based in part on the Federal Power Commission's predictions of the nation's future power requirements and the increasing percentages of that power that will come from nuclear sources. He visualized that the annual production rate of ^{239}Pu will increase from about 20,000 kg in the 1970-1980 period to 60,000 kg in the 1980-1990 decade, and to 80,000 kg in the period 1990-2000. Based on current trends in the

TABLE I
PLUTONIUM ECONOMY OF THE FUTURE*

	Annual Production and/or in Use (kg)		
	1970-1980	1980-1990	1990-2000
Plutonium-239 Power Production	20,000	60,000	80,000
Plutonium-238 Space Applications Medical Applications	10-20	100 5	-- 6,000
Transplutonium Isotopes Curium-244 Californium-252	40 0.1	180 0.8	200 3.5

*G. T. Seaborg (October 5, 1970).

space program and visualized applications in the biological and medical field, he postulates the rate of production and use of ^{239}Pu could increase from 10 to 20 kg in the 1970-1980 period to 100 kg in 1980-1990 with the amount in use in power sources for mechanical heart pumps reaching perhaps 6000 kg near the turn of the century. This is a staggering amount of ^{239}Pu when one puts it in terms of ^{239}Pu equivalents by multiplying by a factor of ~ 270 , the ratio of their specific activities. Dr. Seaborg visualizes also that the production rate and utilization of the transplutonium isotopes of ^{244}Cm and ^{252}Cf could reach 200 and 3.5 kg/yr, respectively, by the year 2000. These are not inconsequential amounts of radioactivity when one considers that the half-life of ^{244}Cm is 18 yr and ^{252}Cf is 3.5 yr. As the subject of this conference is directed toward methods of quantitating plutonium in the environment, no further consideration need be given to these latter materials. To appreciate more fully Dr. Seaborg's plutonium economy of the future, a little more discussion might be in order.

Plutonium-239 and Power Production

The trend in annual rate of production of ^{239}Pu reflects, of course, the increasing national power needs over the next three decades before commercial thermonuclear energy production may become a technical and economic reality. Figure 1 shows the Yankee atomic electric station near Rowe, Massachusetts, the first electric generating plant built under the AEC's Power Demonstration Reactor Program. Reactors of this type, the first to supply commercial power, utilize only the ^{235}U

constituting approximately 0.7% of natural uranium. Their inefficient utilization of the nation's natural resources of uranium eliminates them as a candidate for meeting the nation's expanding power needs. The current generation of power reactors [Light Water Reactor (LWR)] is based on a plutonium-enriched fuel cycle. Plutonium produced during operation is separated and added back to the fuel, resulting in about one-third of the total heat output coming from plutonium fission with production of more plutonium for recycling. This recycling of the by-product plutonium increases the efficiency of utilization of the nation's uranium resources but still requires substantial amounts of new natural uranium. The next generation of reactors is already a subject of extensive research and development by both the AEC and industry. This generation is the Liquid Metal Fast Breeder Reactor (LMFBR) and utilizes the energy inherent in ^{238}U . Such a reactor will breed ^{239}Pu from ^{238}U and will derive about 80% of its energy output from ^{239}Pu fission and the other 20% from fast fission of ^{238}U , while producing enough additional plutonium to provide fuel for new reactors. This progression of power output through increased production and utilization of ^{239}Pu accounts for the increasing rate of production of the latter as projected by Dr. Seaborg and concurrently for its increasing potential as an environmental contamination problem.

Plutonium-238

The potential for production of ^{238}Pu increases directly with increasing production of nuclear power. In many respects ^{238}Pu is an ideal fuel for reliable

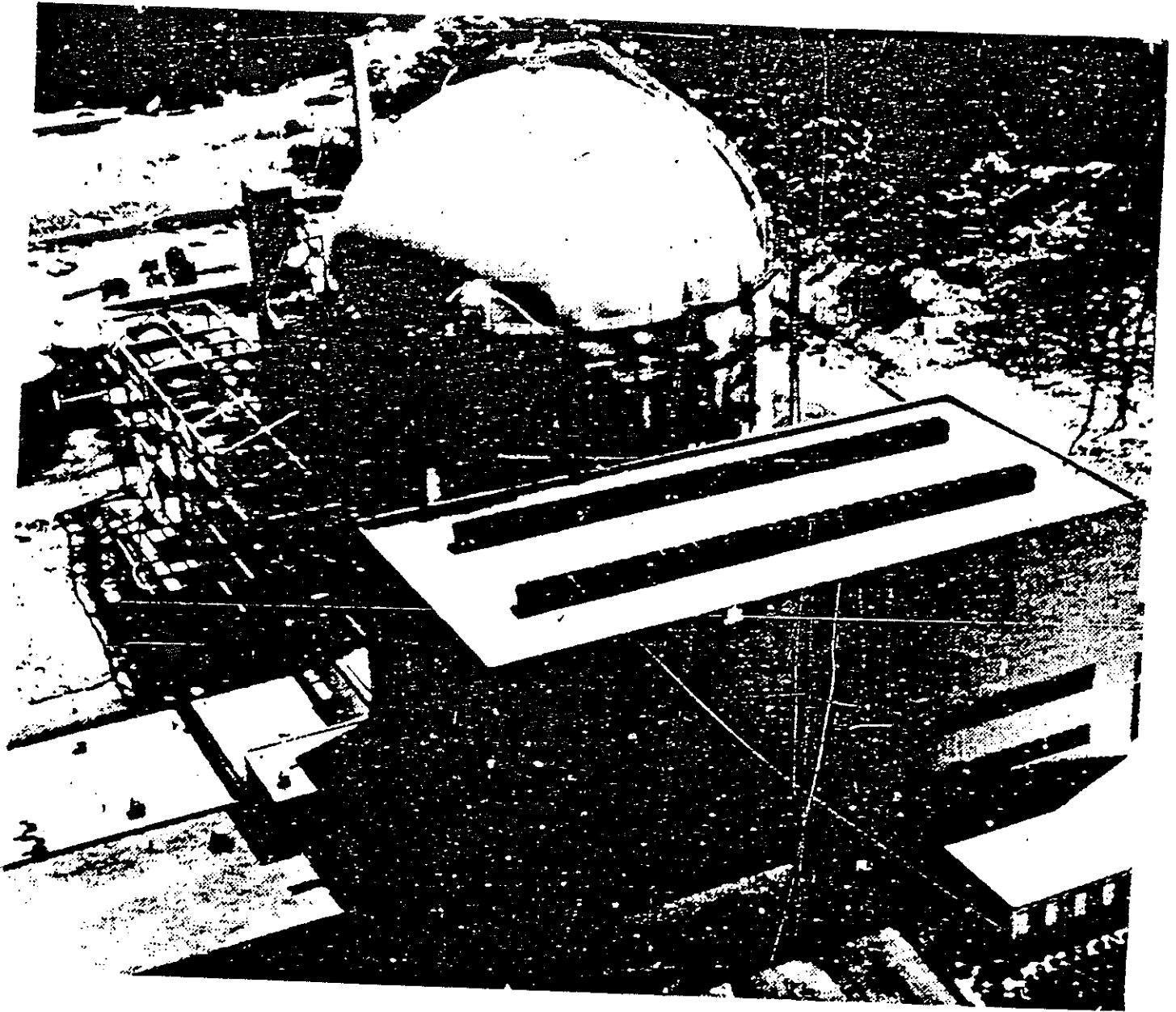

Fig. 1

thermoelectric generators having a high ratio of power output to weight and volume. Such generators are finding, and will continue to find, numerous novel and unique applications as production capability and cost of ^{238}Pu become more and more favorable.

Space Applications. Figure 2 shows the fuel capsule and graphite fuel cask of the SNAP-27 thermoelectric generator. The fuel capsule contains thousands of curies of ^{238}Pu in oxide form and has an output of about 1500 W of thermal power. Three of these devices are already powering experimental stations on the moon (Apollos 12, 14, and 15), and a fourth (Apollo 13) resides intact in the deep trench of the South Pacific Ocean. Other similar ^{238}Pu oxide heat sources are providing power for orbiting weather and navigational satellites.

Undoubtedly these applications will increase and new ones will develop over the next two decades such as power supplies for condensers of biological wastes on long-duration manned space missions and orbiting space stations. Other foreseeable space needs during the next decade or so are for power supplies on non-manned planetary fly-bys and landings such as the Grand Tour of the planets and the Viking program already in the planning stage.

Biological and Medical Applications. Some of the most novel and intriguing applications of ^{238}Pu sources are in the realm of biology and medicine. One already beginning to be applied is as a battery for circulatory-assist devices, an example of which is the heart pacer (Fig. 3). In this application each device requires about 0.5 g of

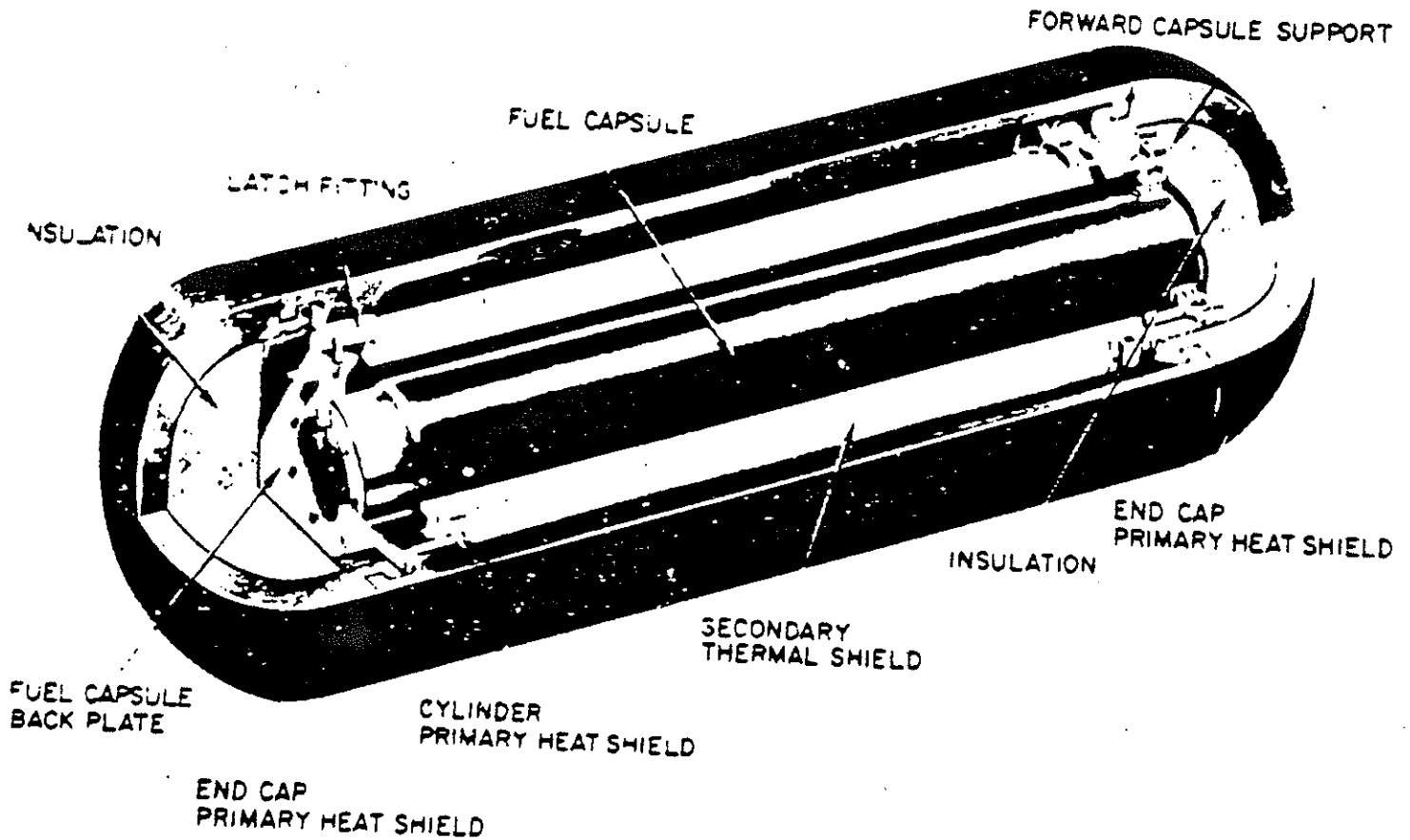

Fig. 2

plutonium as the oxide. The most imaginative application of ^{238}Pu in medicine is that of a power supply for a mechanical pump to totally replace the human heart (Fig. 4). In this case, each mechanical heart would require about 54 g. of ^{238}Pu as $^{238}\text{Pu}^{16}\text{O}_2$. The reason, of course, for using the ^{16}O oxide in such applications is to lower the neutron exposure of the recipient by eliminating the α, n reaction that occurs with normal abundance ^{17}O . If the formidable biological, medical and mechanical problems of this application can be overcome in the 1990-2000 period, Dr. Seaborg visualizes that there might be as much as 6000 kg of ^{238}Pu committed to this use by the turn of the century.

Environmental Plutonium Contamination

Animal experiments beginning with the first injections of plutonium into rats in April 1944 by J. G. Hamilton and his colleagues at the University of California, have shown unequivocally that this material, taken into the body in sufficient quantity, will produce undesirable effects (including cancer) in animals and undoubtedly in man. If the role of plutonium in our future economy is to approach remotely the projected levels,

there must be a continuing program to prevent unacceptable buildup of contamination in the environment. Generalized contamination, as seems to have occurred with mercury, must not be allowed to happen. That is why professionals such as you attending this symposium are important now and will become progressively more important in the future. One can visualize a number of ways whereby plutonium may be discharged advertently or inadvertently into the environment. Potentially at least, nuclear power plants can disperse plutonium into the environment through improper discharge of gaseous and liquid effluents and through accidents that disrupt the integrity of containment. Plutonium processing and fabrication plants can contaminate the environment through improper gaseous, liquid, and solid waste management and can have accidents such as facility fires and storage and transportation mishaps involving the raw materials as well as the processed or finished products. Plutonium-238 thermoelectric generators can be involved in fabrication, transportation, and deployment accidents. As examples, space power generators could be involved in launch-pad explosions, launch aborts and orbital decay with reentry and atmospheric burnup or impact disruption. Contaminated waste management, of course, is of paramount importance in controlling environmental contamination.

Plutonium-238 heart pacer

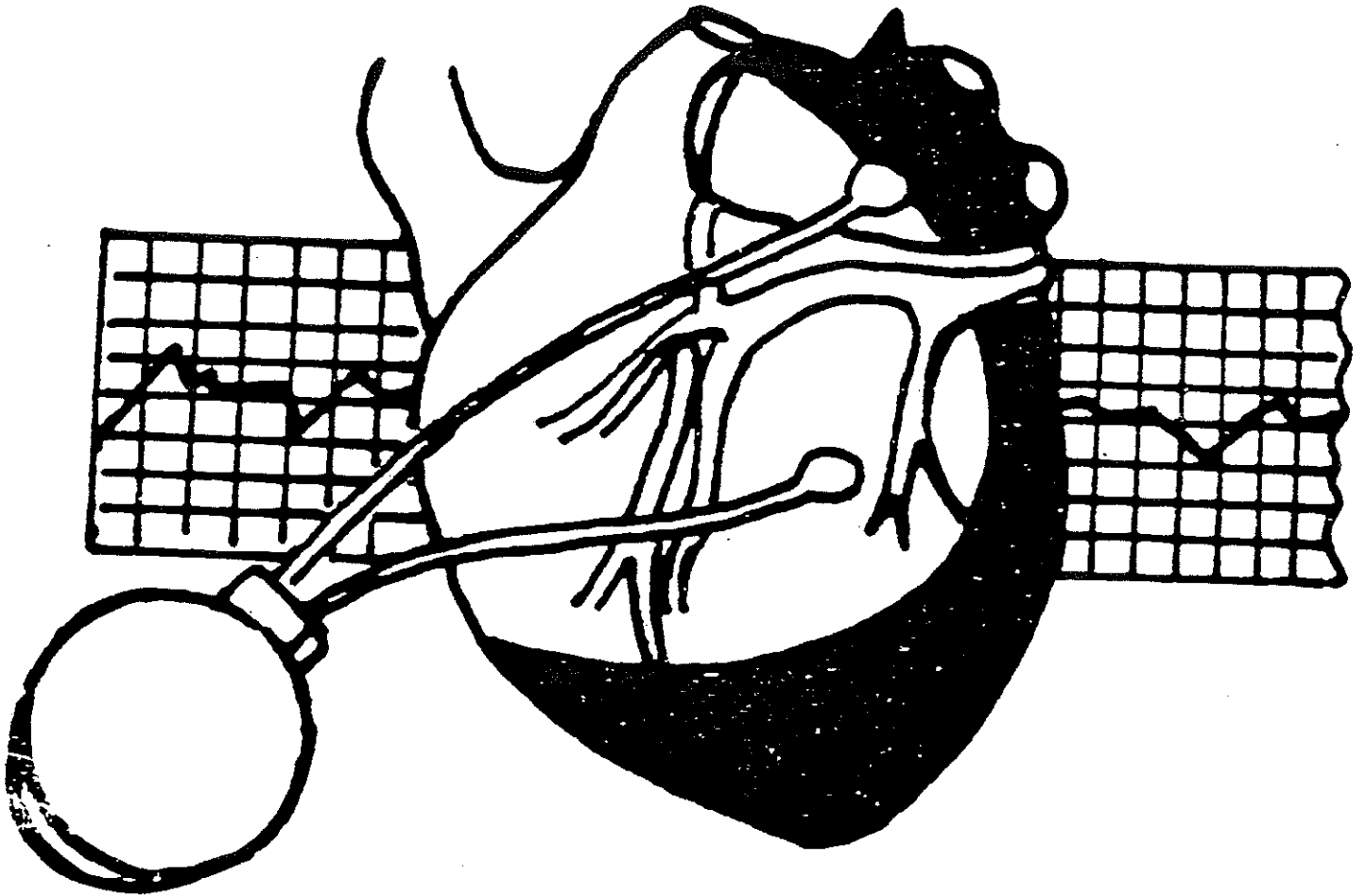

Fig. 3

Any one of these potential sources of environmental contamination could constitute an entire symposium within itself. I have purposefully refrained from mentioning nuclear weapons and weapons testing as potential sources of environmental plutonium contamination which, hopefully, will disappear in the near future.

In all cases, prevention of environmental contamination must rely on sound, effective engineering, the effectiveness of which must be under continual surveillance with appropriate and practical methods of monitoring and analysis which, of course, is the primary topic of this symposium.

Environmental Plutonium Contamination in Relation to Man

Plutonium released to the environment can enter man either directly through inhalation of atmospherically-suspended material or indirectly through incorporation into his food chain.

Atmospheric Suspension and Inhalation. Figure 5 shows a schematic representation of direct exposure of man via inhalation of atmospherically-suspended plutonium. There are two modes of exposure, the first being

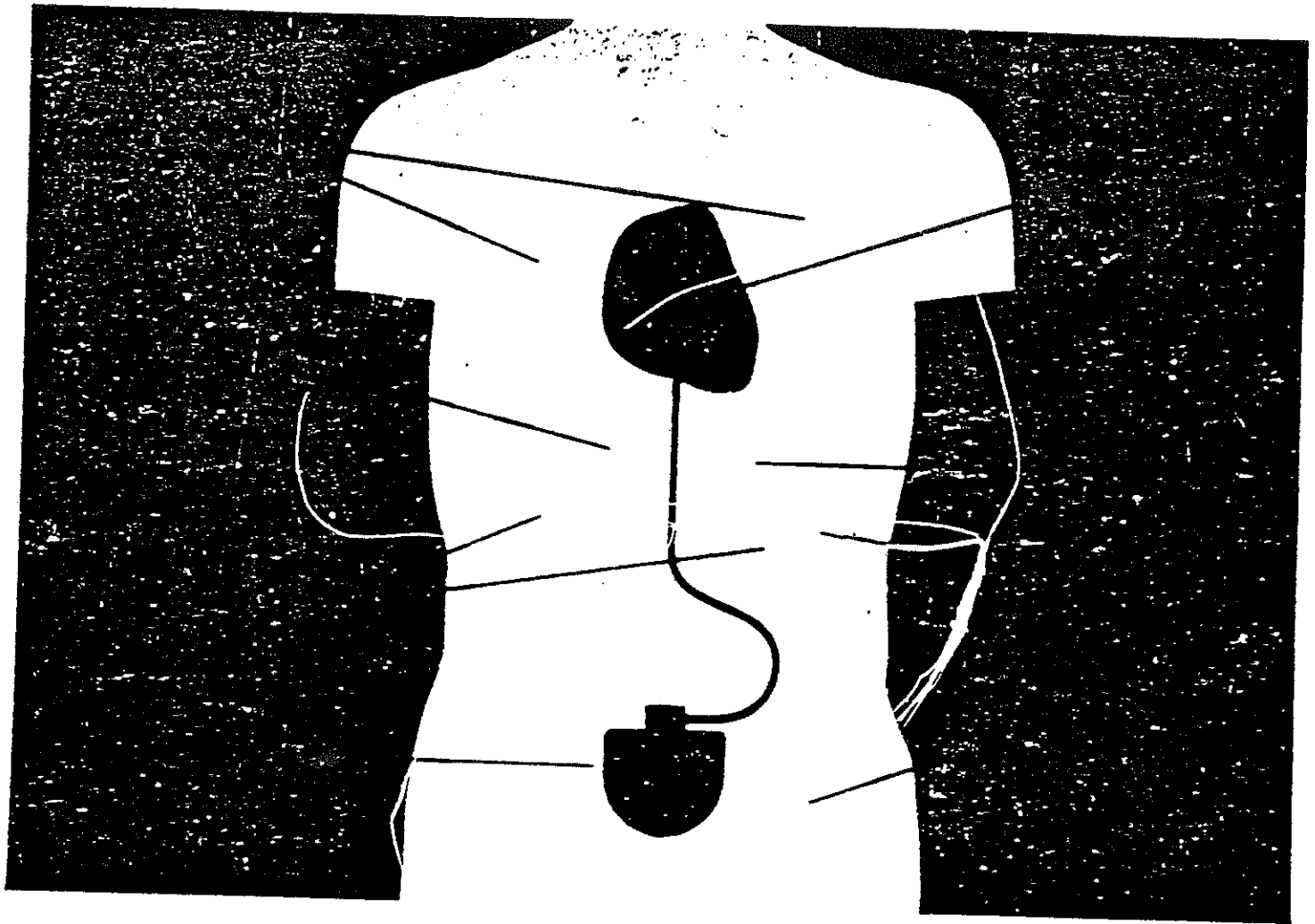

Fig. 4

inhalation of particles from the primary contaminating source prior to surface deposition and the second inhalation of particles resuspended in the atmosphere from the contaminated surface subsequent to deposition. In the first case, the material to which the subject is exposed is already suspended [that is, the suspension factor (S_f) is unity]. Conceptually, at least, estimation of exposure under this condition is easier than for the second, since exposure is dependent on air concentration at the point of interest, particle size distribution, inhalation rate, time of exposure, and chemical form of the plutonium. Of course, if one wishes to relate exposure back to the primary source term (e.g., discharge from a processing plant stack, noncritical detonation of a plutonium-bearing nuclear warhead, etc.), the problem is far more complex. The problem now requires consideration of a long list of additional variables involving meteorological factors and physical aspects of the specific incident. The second mode of exposure, inhalation of resuspended material, is complicated even further by introduction of even more variables, some of which are poorly defined if at all. This mode of exposure is represented on the right of Fig. 5. The problem now is to estimate inhalation exposure of an

individual living in a contaminated area for a life time or any fraction thereof. Undoubtedly, exposure will depend on how much of the source term (in this case, the amount of plutonium deposited on the surface) gets resuspended into the breathing zone [that is, the resuspension factor (R_f)]. R_f is dependent on a staggering number of inter-related variables involving ill-defined phenomena that within themselves vary from place to place and with time. Among these are nature of the contaminated surface (soil type, vegetative cover, asphalt, etc.) and local micro-meteorology (turbulence, wind velocity, rainfall, etc.). In addition, the fraction of the source term (amount deposited) available for resuspension varies with time at some rate interrelated to such other factors as soil type, vegetative cover, rainfall, etc. This attenuation of the source term is designated as λ_p in Fig. 5 and has been estimated at ~ 40 days for prevailing conditions at the AEC's Nevada Test Site. In case these are not complications enough, still another is the amount of local physical activity (vehicular traffic, grazing cattle, plowing, etc.) in the area which, incidentally, will also perturb λ_p . At present at least, it is virtually impossible to calculate exposure in this situation from first principles. This

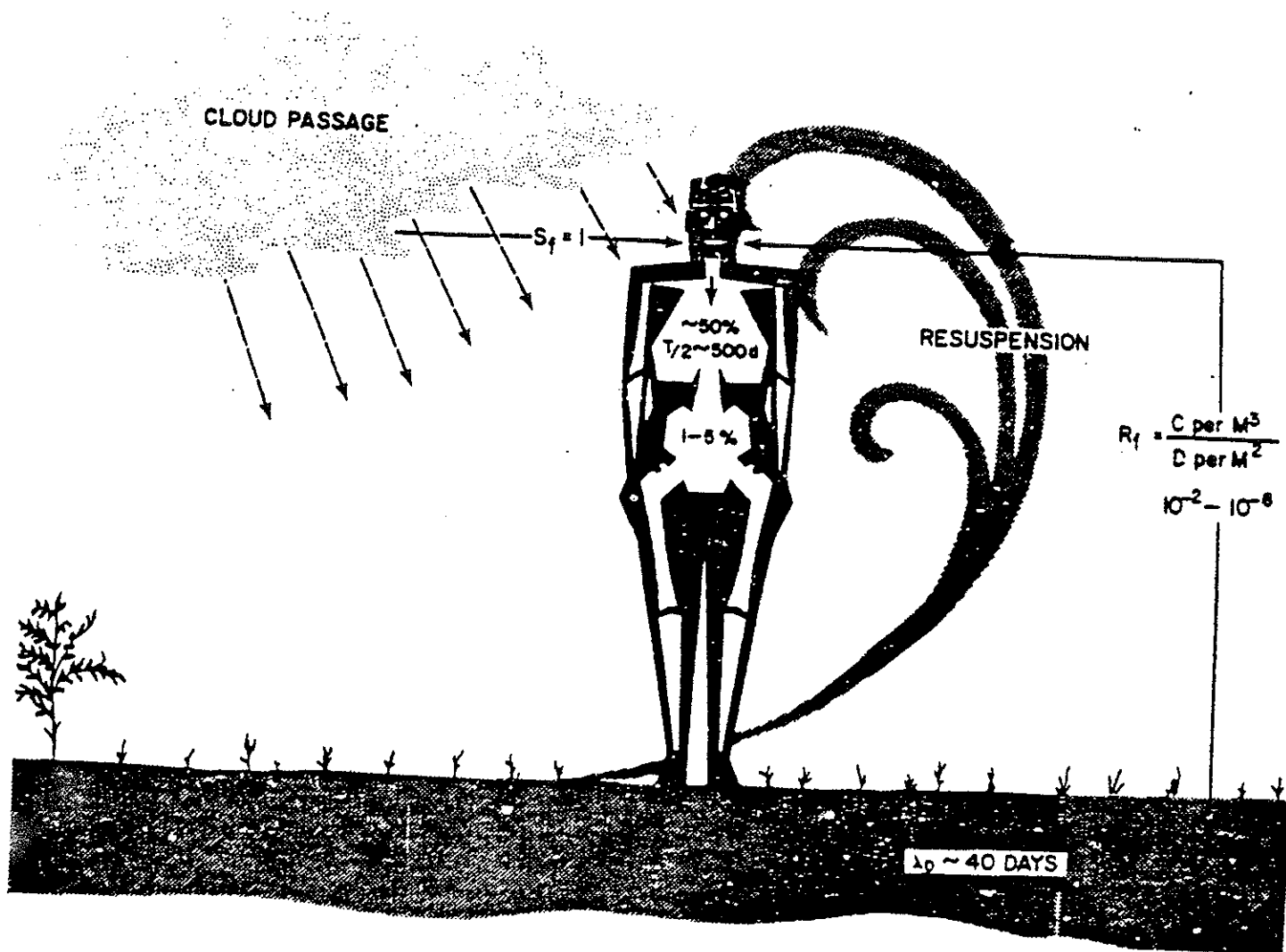

Fig. 5

impossible situation led me and a former colleague (Dr. P. S. Harris) to derive a resuspension factor empirically. In 1956, under the pressures of a sudden anxiety over the hazards of noncritical detonations of plutonium-containing nuclear warheads, we performed a series of quick experiments in an area of known surface plutonium deposition at the Nevada Test Site. Air concentration and surface deposition measurements had been made at the time the contaminating event occurred. At two different times after the event, air samplers were set up and resuspended plutonium resulting from extensive vehicular traffic in the area was measured. From this we concluded that a resuspension factor

$$S_f \approx \frac{\text{Air Concentration (in } \mu\text{g plutonium}/\text{m}^3)}{\text{Surface Deposition Plutonium (in } \mu\text{g}/\text{m}^2)} \approx 7 \times 10^{-5} \text{ m}^{-1}$$

applied to disturbed Nevada desert conditions and that the attenuation factor $\lambda_p \approx 35$ days. An attempt was made also to calculate resuspension factors by other means that might apply under other conditions. Derivation of a resuspension factor from equilibrium calculations with dusty rural air gave a value of 7×10^{-6} . On the

basis of these resuspension factors, it was estimated that the life-time tolerance surface deposition levels for plutonium were $0.7 \mu\text{Ci}/\text{m}^2$ and $7.0 \mu\text{Ci}/\text{m}^2$, for the respective sets of conditions. On the basis of data collected during Nevada Test Operations Plumbbob and Roller Coaster (during which resuspension was studied), the life-time tolerance surface concentration was estimated to be $70 \mu\text{Ci}/\text{m}^2$ for undisturbed regions comparable to the Nevada desert.

My perpetration and application of the resuspension factor have added more to my infamy than all the other infamous deeds of a 26-yr-career. In the first place, from the scientific point of view, the resuspension factor as presented here is aesthetically nauseating and simple-minded. It assumes that the surface deposition level in the immediate vicinity is the all-important factor in determining the air concentration above the contaminated surface and ignores the myriad of factors on which resuspension depends. In the second place, the resuspension factor as an empirically derived value applies only to the conditions prevailing at the time of derivation. Reported values range all the way from about 10^{-2} to 10^{-11} . Intuitively, I feel

that a factor of about 10^{-6} is a reasonable average value to use in estimating the potential hazard of occupancy of a plutonium-contaminated area; however, intuition is not a convincing argument. This aspect of the potential relationship of man to plutonium environmental contamination has been emphasized primarily to emphasize the need for much more very difficult and sophisticated work on the resuspension problem.

Plutonium Incorporation into the Food Chain.

Figure 6 is a schematic representation of the steps along the food chain from soils to man. Approximately 50% of man's food is derived from animal products, according to the progression on the left, and about 50% directly from plants, according to the progression on the right. The amount of environmental plutonium transferred to man depends on the degree to which plutonium is concentrated or discriminated against at each step in the progression. The ratio of the concentration in the product to that in its precursor is expressed as a discrimination factor. As

an example, the concentration of plutonium (taken in through the root system) per g of plant to the plutonium concentration per g of soil is about 5×10^{-5} ; however, deposition on plant surfaces may be a greater source of contamination of plants than uptake via the root system. Multiplication of the discrimination factors along the progression gives a crude estimate of the relationship between environmental plutonium contamination and man via dietary intake. The discrimination factors, of course, are in some cases only crude estimates; however, they are good enough to show that incorporation of environmental plutonium contamination into man via the food chain could be significant only when the environmental contamination levels are completely intolerable for other reasons. Additional ecological studies and more refinement of ecological discrimination factors are needed, however, to provide public assurance and to establish unequivocally that important factors have not been missed. Uptake of plutonium is influenced by chemical form, and absorption from the gastrointestinal tract is

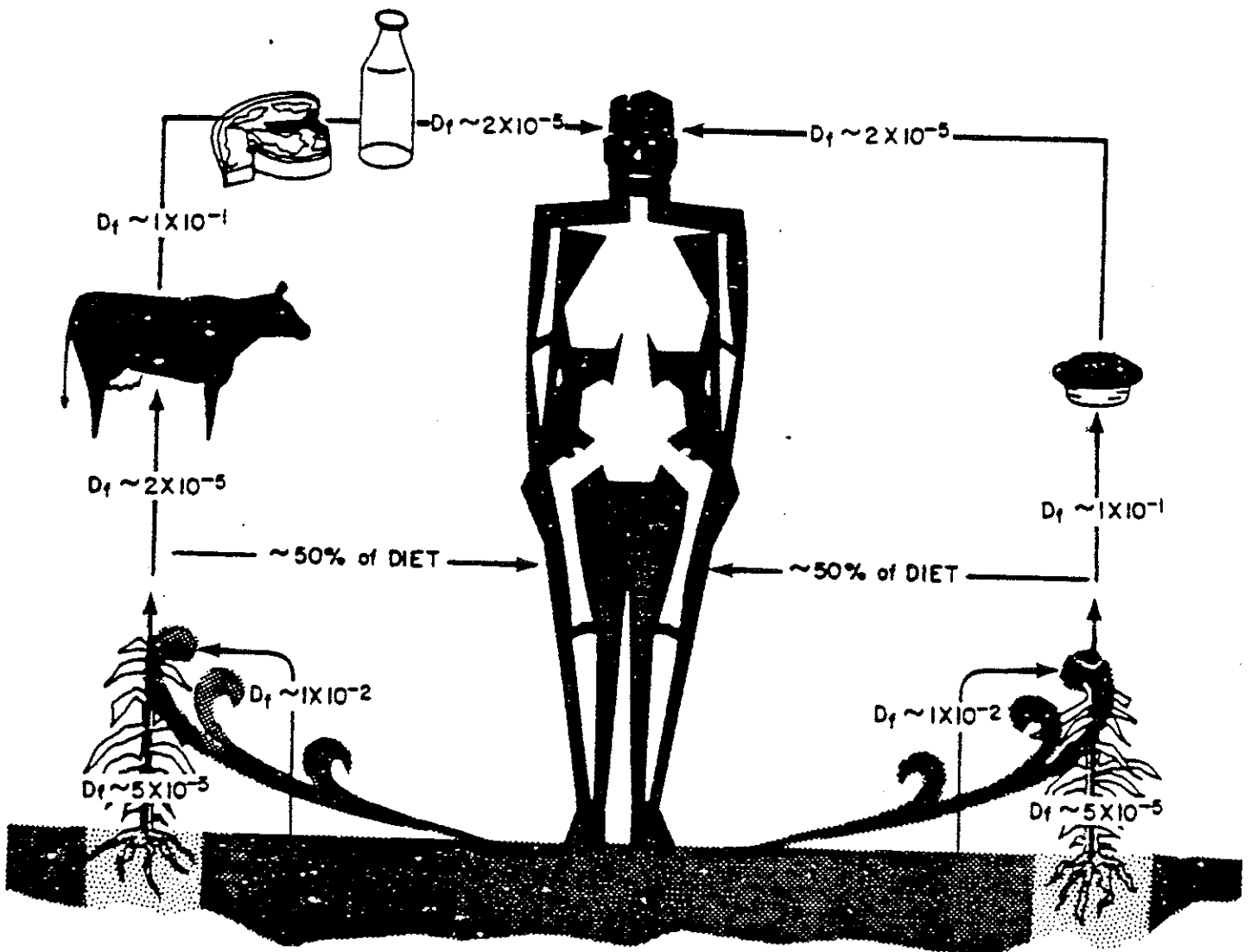

Fig. 6

a factor of about 100 higher for very young animals than for older ones of the same species. Also information on plutonium uptake and transmission in aquatic chains is sparse indeed. Certain aquatic lower species are known to concentrate plutonium by factors of 3000 to 4000. Effect of environmental modification and aging of plutonium deposits on ecological incorporation should be considered. All of these considerations require continual refinement of monitoring and analytical methods and the development of new techniques. As you are all aware, one of the most critical problem areas is that of representative environmental sampling.

In summary, the projections of plutonium production and utilization during the next three decades are a bit staggering to say the least. The technology to produce the projected amounts is virtually assured. Whether the projections offered by Dr. Seaborg and the Federal Power Commission come about will depend on sophisticated cost-effective engineering to control environmental contamination and continual environmental surveillance to check on engineering effectiveness and to convince an apprehensive and occasionally skeptical public that the gain is worth the risk.

WORLDWIDE PLUTONIUM FALLOUT FROM WEAPONS TESTS

by

John H. Harley
Health and Safety Laboratory
U.S. Atomic Energy Commission
New York, N. Y.

ABSTRACT

The testing of nuclear weapons up to the beginning of the moratorium distributed about 300 kCi of ^{239}Pu over the surface of the earth. Tests by France and Communist China have probably added about 5% to that.

The concentrations of plutonium have been measured in the stratosphere and surface air. Over the past 10 years, data on deposition rate and cumulative deposit are very scarce and information on the plutonium in the biosphere is even scarcer.

The introduction of 17 kCi of ^{238}Pu from a SNAP generator has increased our interest in the fate of plutonium. Additional measurements are being carried out and the Health and Safety Laboratory has performed a worldwide soil sampling to evaluate distribution of ^{238}Pu . Comparable data on ^{239}Pu will also be obtained.

Plutonium has been produced in both the fission and fusion weapons that have been tested. The yield of plutonium per megaton of explosive force varies considerably as a function of weapons design but it is probably valid to look at the total weapons debris and consider that there is some average plutonium yield. Our work at the Health and Safety Laboratory or the work available for discussion is not aimed at weapons diagnosis and we are largely confined to considering the ratio of ^{239}Pu to ^{90}Sr as our yield indicator. In this paper I will try to show how much plutonium has been produced in weapons testing and what the present distribution is. The ^{238}Pu introduced by the burn-up of a SNAP-9A device is not strictly a matter of weapons testing but it is certainly related to the overall plutonium problem and I will include it in the discussion.

Production of ^{239}Pu

The combined testing of all the nuclear powers through 1962 had a fission yield of 200 Mt. This can be translated into a production of 20 MCi of ^{90}Sr and a plutonium production of about 0.4 MCi. This latter figure will be refined somewhat in a later discussion.

Testing in the atmosphere during the moratorium has continued, with France carrying out a number of tests in the southern hemisphere and Mainland China a number in the northern hemisphere. The total fission yield of these tests through 1969 has been about 5% of the yield of the pre-1963 testing.¹

Plutonium-239 Data

The plutonium data that are available include measurements in the stratosphere with aircraft and balloons, measurements of surface air, measurements of monthly deposition rate, and cumulative deposition on the ground. Some information has been published on plutonium in the biosphere. I will try to review the data and to point out some of the inferences that may be drawn.

Stratosphere. Measurements of ^{239}Pu in the stratosphere have been part of all the programs in this region, and data are available from 1957 to date. The balloon concentrations and ratios are not shown specifically with the aircraft measurements but are included in the inventories given later.

Concentrations of ^{239}Pu in the stratosphere change with time, with testing, and with meteorological factors. Thus I have chosen to calculate the $^{239}\text{Pu}/^{90}\text{Sr}$ ratios, which will change only if the pattern of weapon types changes. Data for the High-Altitude Sampling Program (HASP), the Stardust Program of the Defense Atomic Support Agency, and the Airstream Program of HASL are shown in Table I. These ratios are sufficiently constant so that the megaton weapons whose debris enters the stratosphere can be considered as a single source.

The stratospheric material is removed with a half-life of about 1 year. This is illustrated for the ^{90}Sr inventory in Fig. 1, and since the $^{239}/^{90}$ ratio remains constant, the ^{239}Pu is leaving the stratosphere at the same rate.

Surface Air. Because plutonium has been considered to be almost exclusively an inhalation hazard, measurements have tended to emphasize surface air concentrations. The stratospheric $^{239}/^{90}$ mean ratio of about 0.017 may be compared with the surface air ratios in Table II. The early data are in good agreement, but later ratios for surface air seem to be higher.

The actual concentrations of ^{239}Pu in surface air are given in Table III. The Soviet data appear to be low, and no check is available since ^{90}Sr was not measured. Otherwise, you might say that the mean level was about 0.1 pCi per 1000 standard cubic meters for the years since 1965. This is about a factor of 10^5 below the ICRP recommendation for the occupational exposure to insoluble plutonium at 168 h per week ($10^{11} \mu\text{Ci}/\text{cm}^3$). For soluble plutonium, the recommended level is 15 times lower.

There were relatively few measurements of ^{239}Pu in surface air before 1965, but we can make some estimates based on ^{90}Sr data. The peak concentration in the

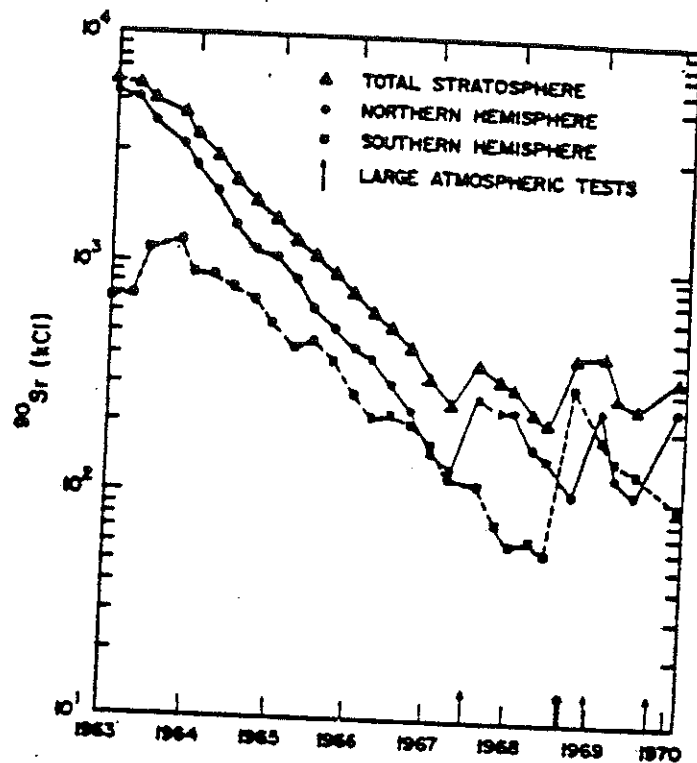

Fig. 1

northern hemisphere occurred in 1963, when a value of 100 pCi of ^{90}Sr per 1000 m^3 was found. This would be about 2 pCi of $^{239}\text{Pu}/1000 \text{m}^3$. On a broader basis,² the northern hemisphere average for 1963 was about 40 pCi/1000 m^3 for ^{90}Sr and the average for 1958-59, after the large tests, was about 10 pCi/1000 m^3 . These would correspond to 0.8 and 0.2 pCi $^{239}\text{Pu}/1000 \text{m}^3$, respectively. The former value is in reasonable agreement with the values measured at Ispra³ and shown in Fig. 2.

TABLE I

$^{239}/^{90}$ RATIOS IN THE STRATOSPHERE

Program	Period	No. of Samples	$^{239}/^{90}$	Reference
HASP	8/57 - 6/60	342	0.017	(17)
Stardust	6/61 - 12/61	13	0.019	(18)
	1962	70	0.015	
	1963	44	0.016	
	1964	42	0.017	
	1965	182	0.017	
	1966	255	0.018	
Airstream	1967	207	0.021	(19)
	1968	233	0.021	
	1969	209	0.016	
	1/70 - 8/70	160	0.017	

TABLE II
239/90 RATIOS IN SURFACE AIR

Location	Period	239/90	Reference
Winchester, Mass.	5/65 - 2/68	0.017	(15)
	3/68 - 3/69	0.028	
Over Atlantic	67 - 68	0.013	(5)
Japan	58 - 66	0.016	(16)
	67 - 68	0.023	
Ispra, Italy	7/61 - 12/65	0.022	(3,14)
	1966	0.021	
	1967	0.022	
	1968	0.032	
	1969	0.024	
	1970	0.018	
Northern Hemisphere	1965	0.017	(2)
	1966	0.026	
	1967	0.019	
	1968	0.030	
	1969	0.026	
	1970	0.022	
Southern Hemisphere	1965	0.018	(2)
	1966	0.035	
	1967	0.037	
	1968	0.017	
	1969	0.012	
	1970	0.046	

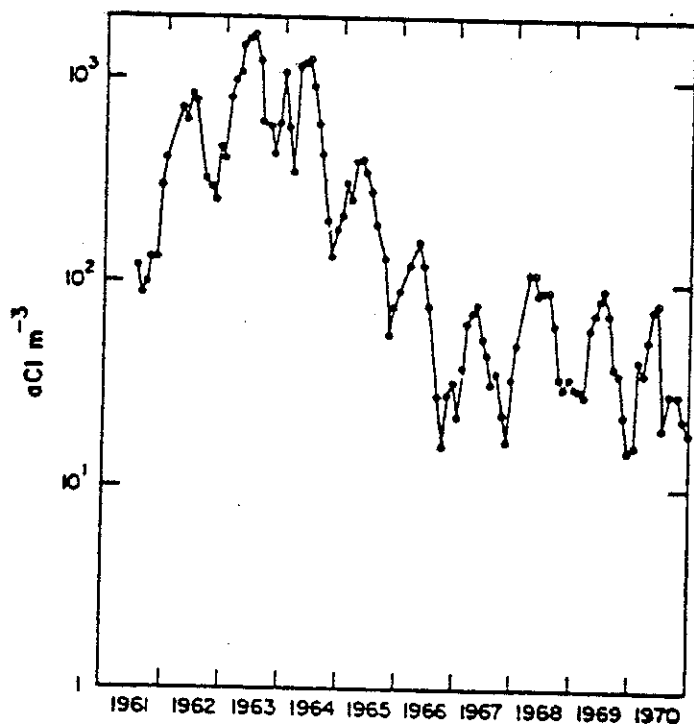

Fig. 2

Deposition. The actual deposition rate and cumulative deposit of ^{239}Pu has received little attention, largely because it was considered to be of little significance, but also because of the tedious chemistry and comparative lack of alpha spectrometers.

Since the deposition of ^{90}Sr was well documented, the use of a general 239/90 ratio should give a good estimate of the plutonium deposition. Figure 3 shows the latitudinal distribution of ^{90}Sr as of 1967,⁴ and multiplying the ordinates by 0.017 should give the ^{239}Pu distribution. Comparable exercises with deposition-rate measurements should also be valid for most of the time period of fallout.

The increased 239/90 ratio after 1965 must be considered for more recent data on rates, but the cumulative deposit was over 98% down by 1965 and later deposition has little effect. It must be remembered, however, that the ^{90}Sr is decaying at a rate of 2½% per year. This means that if we accept a 239/90 ratio of 0.017 at production, the ratio would now be 0.023 for the present cumulative deposit.

The worldwide deposition of ^{90}Sr has been estimated as about 12.8 MCi, with the rest of the ^{90}Sr being accounted for by decay and local fallout at the test sites. The corresponding ^{239}Pu would then be about 300 kCi.

TABLE III
²³⁹Pu IN SURFACE AIR

Location	Period	²³⁹ Pu, pCi/1000 m ³	Reference
Winchester	64 - 69	0.02 - 0.5	(15)
USSR	65 - 66	0.005	(10)
Southern Hemisphere	1965	0.12	(2)
	1966	0.16	
	1967	0.06	
	1968	0.11	
	1969	0.08	
	1970	0.12	
Southern Hemisphere	1965	0.10	(2)
	1966	0.15	
	1967	0.06	
	1968	0.02	
	1969	0.03	
	1970	0.08	

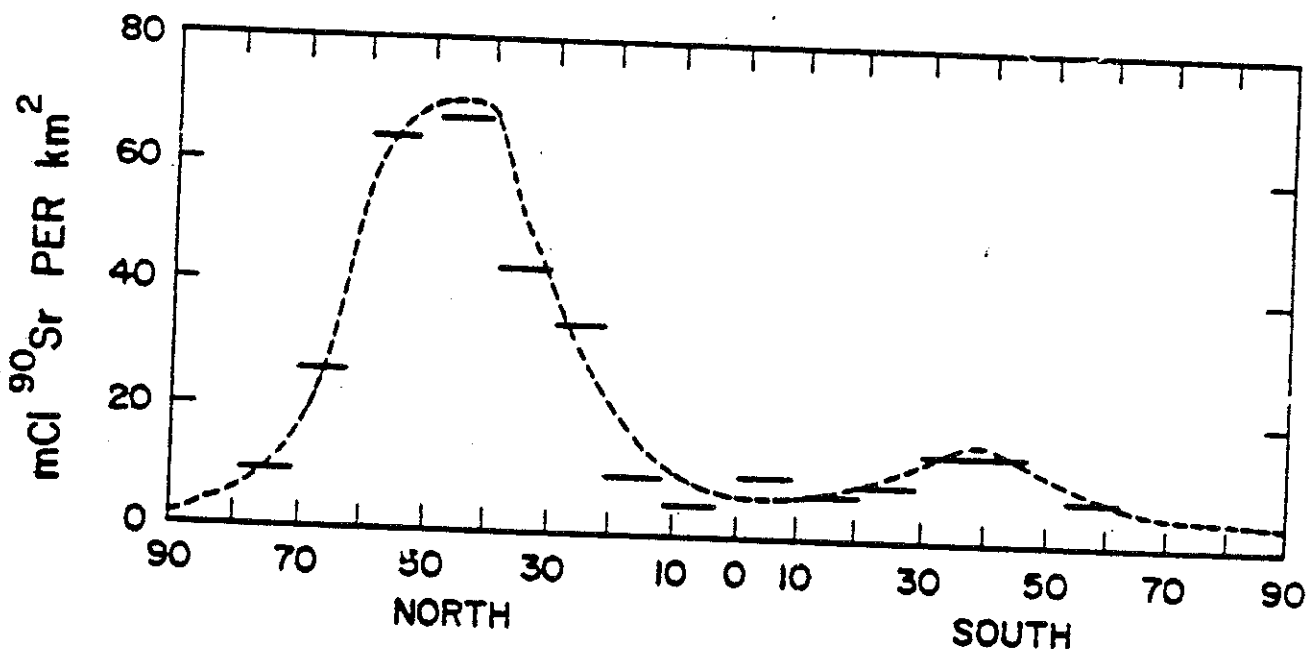

Fig. 3

Plutonium in the Oceans. A number of measurements of plutonium in surface ocean water have been made and Bowen, et al.⁵ have also measured concentrations at depths greater than 500 m. Pillai, et al.⁶ found concentrations of 2 to 3 pCi/1000 liters in the Pacific and Miyake and Sugimura and Bowen et al.⁷ found levels somewhat less than 1 pCi/1000 liters. If you consider the plutonium to be uniformly mixed in the region above the

thermocline, there should be about 10 pCi/1000 liters to be comparable to the land deposition.

Measurements by Bowen et al. of the ²³⁹Pu/⁹⁰Sr ratio showed about 0.006 for depths down to 400 m and twice that for depths greater than 500 m. His interpretation is that the plutonium acts as a sedimentary particulate or is possibly moving by biological sedimentation.

Pillai, et al. indicated that kelp concentrated plutonium by a factor of 1000, and that shellfish and fish gave concentration factors of 200 and 3, respectively, as compared to an equal weight of sea water. Measurements by Wong, et al.⁸ were in general agreement although the data are extremely limited. Wong, et al. indicate that the high concentrations found in sediments might be returned to the environment through the action of bottom feeders.

Plutonium in the Biosphere. The data on plutonium in the biosphere measured by alpha spectrometry tends to be very limited. Magno, et al.⁹ measured air concentrations and total diet as well as human lung and bone during the period 1965-66. Dietary intake was measured as 7×10^{-3} pCi/day. The existing air concentrations would have given an intake of about one-third of this assuming a breathing rate of $20 \text{ m}^3/\text{day}$. The lung samples averaged 0.45 pCi/kg and the bones ranged from 0.04 to 0.12 pCi/kg.

The only comparable data was developed in the USSR by Smorodintseva, et al.¹⁰ They measured air concentrations in 1965, and 1966 to be about 0.005 pCi/1000 m^3 and found lung concentrations of about 0.15 pCi/kg. Their air concentrations are unexpectedly low and should not lead to the lung levels found.

Smorodintseva and coworkers again also checked the pulmonary lymph nodes and obtained concentrations about 50 times higher than the lung. This had been pointed out in earlier work on occupational exposures and is not unexpected.

Plutonium Anomaly. The 239/90 ratios in surface air during 1968-69 exceeded the ratios in the stratosphere at comparable times.¹¹ The apparent enrichment of ²³⁹Pu is not readily explainable, although it appears to be real. It is hoped that the data presently being collected will help to clarify the situation.

Plutonium-238

Our interest in the problem of plutonium distribution and deposition was revived when a SNAP-9A device burned up over the Indian Ocean in April 1964. This unit was fueled with ²³⁸Pu and the fallout systems described above became very useful in evaluating the distribution of this material.

The original satellite contained 17 kCi of ²³⁸Pu. The SNAP debris was first detected in balloon samples taken over Australia at about 33 km in August of 1964. Material then appeared at aircraft altitudes in the southern hemisphere in May 1965 and in the northern hemisphere in December. It finally reached the ground in the southern hemisphere in the spring of 1965. The stratospheric inventory of SNAP ²³⁸Pu is shown in Fig. 4.¹²

A number of the high-altitude filters were examined by Holland¹³ at Trapelo/West to see if they could estimate the particle size. Radioautography indicated that the ²³⁸Pu average size was about 10 μm , although these

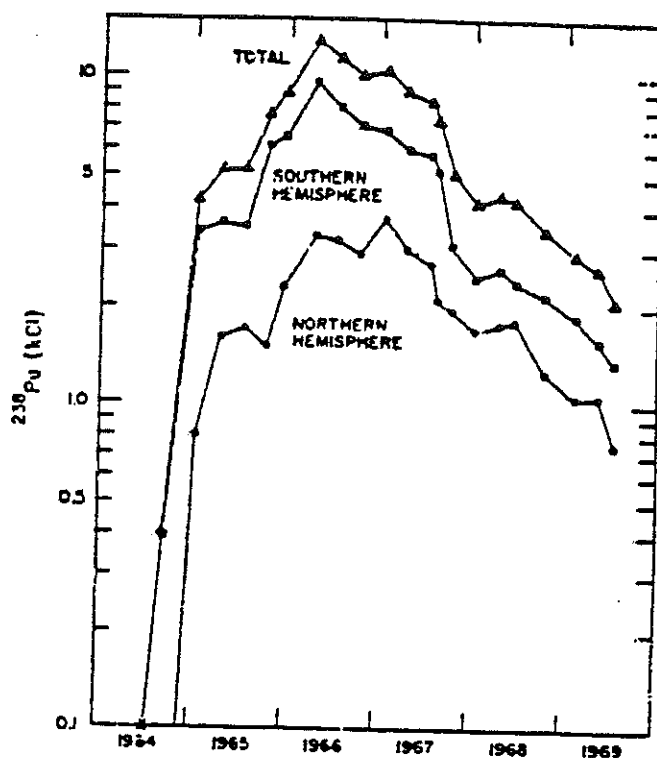

Fig. 4

particles might very well have been associated with larger, inert dust particles.

The concentrations of ²³⁸Pu in surface air have been measured since 1964, but some of the early data are suspect. Table IV shows the 238/239 ratios from 1965 on. It must be remembered that ²³⁸Pu was also formed in weapons tests, and a ratio of 0.03 is what might be considered characteristic of test debris.

The 1968 ratio of almost 2 in the southern hemisphere points out the different origin of the two isotopes and their different behavior. The ²³⁸Pu was distributed mostly in the southern hemisphere, and was introduced after most of the ²³⁹Pu had already been deposited.

We attempted to follow the deposition on a very limited scale by measuring monthly samples from Melbourne, Australia, and New York City. Over the next few years problems were encountered at both stations and a considerable fraction of the data had to be discarded. The only continuing reliable measurements came from Ispra where the EURATOM group analyzed monthly deposition samples^{3,14}. One station isn't too suitable for estimating the worldwide distribution and we have therefore embarked on a program of analyzing soils.

Our soil sampling started last fall and the data should be available this fall. Samples were collected on a worldwide basis by HASL staff and by cooperating scientists in many countries. All samples were taken to a depth of 30 cm to insure inclusion of all the fallout. We hope that analysis of these samples for ⁹⁰Sr will indicate sample validity. Plutonium-239 will also be measured, as well as ²³⁸Pu.

TABLE IV
238/239 RATIOS IN SURFACE AIR

<u>Location</u>	<u>Period</u>	<u>238/239</u>	<u>Reference</u>
Northern Hemisphere	1965*	0.03	(2)
	1966	0.16	
	1967	0.48	
	1968	0.30	
	1969	0.29	
	1970	0.14	
Southern Hemisphere	1956*	0.04, 0.24	(2)
	1966	0.61	
	1967	1.58	
	1968	1.91	
	1969	0.92	
	1970	0.52	

*Part of year only.

If the SNAP ^{238}Pu were uniformly distributed on the earth's surface, the area concentration would be about 70 dpm/m^2 . The problem is compounded by the fact that weapons debris has been found at soil depths greater than 15 cm, so we had to set 30 cm as our sampling depth. Since an average soil will run about 400 kg/m^2 to 30 cm depth, we expect to find about 0.2 dpm/kg for the SNAP ^{238}Pu . This automatically sets the sample size at 1 kg and requires a leaching procedure. We believe that we have sufficient data to indicate that plutonium from weapons tests and SNAP debris can be acid-extracted from kilogram quantities of soil. This may not be true for samples taken near the Nevada Test Site or even for all plutonium processing plants. This would have to be tested on the appropriate samples.

There is some complication in looking at plutonium data in any sample. The weapons debris plutonium contains a small amount of ^{238}Pu , probably of the order of 3%. This value is not well established because good alpha spectrometry was not being used on the samples that were available to us in the pre-SNAP period. The ratio was not a problem during the time of major SNAP fallout because 238/239 ratios reached 1 and above. This will not be true in the soil samples to be analyzed since we have only 17 kCi of ^{238}Pu plus about half as much from testing, as compared to 300 kCi of ^{239}Pu from the tests.

References

1. P. W. Krey and B. Krajewski, "Updating Stratospheric Inventories to January 1970," USAEC Report HASL-239, January 1971.
2. "Results of Surface Air Analyses," USAEC Report HASL-242 (Appendix), April 1971.

3. M. DeBortoli et al., "Pu-239 and 238, Sr-90, and Cs-137 in Surface Air from Mid-1961 - 1965," IRPA Congress, Rome, September 1966.
4. M. W. Meyer et al., "Strontium-90 on the Earth's Surface, IV," USAEC Report TID-24341.
5. V. T. Bowen, K. M. Wong, and V. E. Noshkin, "Plutonium-239 in and Over the Atlantic Ocean," USAEC Report NYO-2174-114.
6. K. C. Pillai, R. C. Smith, and T. R. Folsom, "Plutonium in the Marine Environment," *Nature* 203, 568-70 (1964).
7. Y. Miyake and Y. Sugimura, "Plutonium Content in the Western North Pacific Waters," *Meteorological Research Institute (Japan)*, October 1968.
8. K. M. Wong et al., "Pu-239 in Some Marine Organisms and Sediments," USAEC Report NYO-2174-115.
9. P. J. Magno, P. E. Kauffman, and B. Schleien, "Plutonium in Environmental and Biological Media," *Health Physics* 13, 1325-30 (1967).
10. G. I. Smorodintseva et al., "Study of Uptake of Airborne Pu-239 by the Human Organism," U. N. Scientific Committee Document A/AC.82/G/L.1301, HASL Translation, November 1969.
11. H. L. Volchok and P. W. Krey, "Plutonium-239 Anomaly in the Troposphere," USAEC Report HASL-224, 1-14 to 27, April 1970.
12. P. W. Krey, M. T. Kleinman, and B. T. Krajewski, "Sr-90, Zr-95, and Pu-238 Stratospheric Inventories, 1967-1969," USAEC Report HASL-227, 1-39 to 69, July 1970.
13. W. D. Holland, "Final Report of Studies of Pu-238 Debris Particles from the SNAP-9A Satellite Failure of 1964," Report TLW-6006, May 1968.

14. Euratom Joint Nuclear Research Center, Site Survey and Meteorology Section Quarterly Reports, Reprinted in the HASL Quarterly Reports.
15. B. Schlicien, J. A. Cochran, and P. J. Magno, "Sr-90, Sr-89, Pu-239, and Pu-238 Concentrations in Ground-Level Air, 1964-1969," *Envir. Sci. and Tech.* 4, 598-602 (1970).
16. Y. Miyake, Y. Katsuragi, and Y. Sugimura, "A Study on Plutonium Fallout," *J. Geophysical Res.* 75 2329-30 (1970).
17. J. P. Friend, "The High Altitude Sampling Program," DASA Report 1300, Volume 3, August 1961.
18. H. W. Feely, D. Katzman, and C. S. Tucek, "Sixteenth Progress Report on Project Stardust," DASA Report 1821.
19. P. W. Krey and M. Kleinman, "Project Airstream," USAEC Reports. HASL Quarterlylies, 1967-1971.

DISTRIBUTION OF PLUTONIUM
FROM ACCIDENTS AND FIELD EXPERIMENTS

by

Harry S. Jordan
Los Alamos Scientific Laboratory
University of California
Los Alamos, New Mexico

ABSTRACT

Studies of plutonium in the environment from accidents involving nuclear weapons and from experiments in the field to study health and safety aspects of operational weapons are worthy of careful evaluation. Plutonium fallout from weapon testing is diminishing and, for the immediate future, the signing of the Limited Test Ban Treaty would indicate that additions to the inventory will only be caused by testing at a reduced rate by nations not signing the treaty. Plutonium from routine operations of plutonium facilities has never been a serious problem, and the current AEC drive to reduce plutonium contaminated effluent to the lowest practical concentration should reduce this source of plutonium to a negligible level.

However, as long as plutonium exists as a component of weapons, as sources of power in space as well as on the ground, as a raw material in fabrication plants, and as a waste product in waste-handling facilities, the probability of an accidental release of plutonium to the environment can never be zero.

Reasons for the necessity of desirability to study the documented accidents and field experiments are advanced and outlines of the accidents at Thule, Greenland and Palomares, Spain together with the field experiments, Project 56, Project 57, and Roller Coaster are presented.

Nowadays, discussions regarding plutonium seem to have a certain element of unreality associated with them -- perhaps characterized somewhat by the expression "The Wonderful World of Plutonium." There is even in some cases a reluctance to enter into such discussions, as if it were rather like talking about the virtues of marriage in front of your old maid aunt. There is really no reason for this because plutonium, as a metal, has a fine and exceptional history. By that I mean that materials are used by humans in their affairs for good or for ill, but in the course of this service the materials evolve a history of their own. Almost all the common metals and materials such as coal and cotton have long fascinating histories in which the bright chapters are blighted by very dark chapters. Plutonium, in comparison, does not, and should not

in the future, have such blots upon its history. We have had almost 30 years of documented experience to indicate that our present knowledge and techniques are sufficient to handle this material in quantity with a real margin of safety. It is perhaps worth noting that the accounting for illness, death, and misery that can be attributed to other metals and toxic materials is very incomplete and fragmentary, whereas rather careful surveillance of the people working or involved with plutonium has established its remarkable safety record.

In the years that we have been using plutonium, it has found its way into our environment by three principle means. The source that accounts for the most widespread distribution of plutonium is that created in the upper air by atmospheric testing of nuclear weapons. This source of

plutonium has been diminishing since the signing of the Limited Nuclear Test Ban Treaty in 1963.¹

Plutonium, in small amounts, has been dispersed into local environments by effluents from facilities handling plutonium, but this dispersal has been carefully controlled and has not created a health hazard. Moreover, the current well-financed AEC effort to reduce plutonium concentrations in effluents to the lowest practical level will, for all practical purposes, eliminate any real concern about plutonium in the environment from this source.

Plutonium dispersed into the environment as a result of accidents, however, will always, in some measure, be a problem. If we are to make full use of this metal as a vital element in our national defense efforts, as a power source in space, as well as on land and sea, and as an element in medical devices, we must accept the certainty that accidents will happen and that plutonium will be distributed to some extent in our environment.

A large portion of the information that has been developed concerning the dispersal of plutonium from accidents is in classified documents. Certainly, access to classified information is required to completely understand the reports of the actual accidents and the field experiments. I was going to say that this is unfortunately the case, but in reality it is fortunate that accidents, except in the case of nuclear weapons, have not created any major environmental health problems.

Probably the first release of plutonium was an experiment conducted by the Los Alamos Scientific Laboratory in the early days of the Nevada Test Site. The purpose of the experiment was to determine the properties of plutonium when subjected to forces generated by the detonation of high explosives. The monitoring effort was directed primarily toward protection of the workers. This event is mentioned here only to note that AEC-NVOO has appointed a committee to study sites with old plutonium contamination and that the Reynolds Electrical and Engineering Company, the support contractor for the Nevada Test Site, is now engaged in collecting preliminary data from this area.²

The first field experiments for evaluating weapon safety were conducted by the Los Alamos Scientific Laboratory in 1955 and 1956 in an operation called Project 56. These experiments were required to establish design parameters to ensure that weapons involved in accidents would not produce a nuclear yield. A total of four events was necessary to develop the needed data. The study of the plutonium contamination levels produced in the environment by the experiments was considered to be of secondary importance, but a quickly assembled group of people produced data on air and ground contamination levels as a function of distance.³ As part of the overall effort, personnel on the H-Division staff of the Los Alamos Scientific Laboratory produced, on a crash basis, a hazard evaluation for the release of plutonium from a weapon involved in an accident.⁴ One of the conclusions that evolved from this theoretical evaluation, bolstered by pertinent environmental data from Project 56, was that

100 $\mu\text{g Pu/m}^2$ on the ground would be safe for a lifetime occupancy. The authors, well aware of the uncertainties and assumptions that had gone into this urgently needed evaluation, strongly recommended additional studies of the accident case.

The need for additional data, acknowledged by the AEC and DoD, led to the experiment conducted by Test Group 57 Operation Plumbbob⁵ in 1957. Four broad areas of interest were studied.

- Means of estimating distribution and long-term redistribution of plutonium dispersed by a nonnuclear detonation.
- Biomedical evaluation of a plutonium-laden environment.
- Evaluation of decontamination methods.
- Alpha survey instrumentation and field monitoring procedures for the prompt estimation of levels of plutonium contamination.

The various studies produced data that should be more widely distributed and should be subjected to additional analysis. The figure of 3500 $\mu\text{g Pu/m}^2$ was established as safe for lifetime occupancy with normal activity, i.e., weather as the sole resuspension force, being an important stipulation. The number generally associated with Project 57, however, is 1000 $\mu\text{g Pu/m}^2$.

Data from this single release did not settle all of the questions and uncertainties that bothered the AEC and DoD in their efforts to develop proper criteria for the storage and transportation of nuclear weapons. Sharing this concern was the Atomic Energy Authority of the United Kingdom. The three agencies therefore sponsored Operation Roller Coaster.

The field experiments were carried out jointly by United States and United Kingdom personnel in 1963 on the Tonopah Test Range in Nevada. The objectives of the operation were:

- To make measurements of plutonium to permit its distribution and behavior during cloud travel to be determined.
- To obtain data to permit complete characterization of the aerosols in the cloud.
- To determine the lung deposition and fate of plutonium inhaled during cloud passage by several animal species; to compare animal data with air sampling data and attempt to estimate the dose to man from inhalation.
- To evaluate the effects on the dispersal of plutonium of varying amounts of earth cover on storage configurations.

• To further develop the model describing cloud behavior and particle deposition using sedimentation and turbulent diffusion theory so that plutonium releases in a variety of weather conditions could be estimated.

Prior to conducting the experiment, United States and United Kingdom personnel had agreed that no attempt would be made to obtain resuspension measurements because of the complex nature of the process and the effort required. The difficulties and complexities are not to be denied, but the inability to fund or to interest a qualified group to investigate the resuspension of plutonium is a matter to be regretted. This is particularly true since much of the basic data required in a resuspension study, i.e., the level of plutonium contamination on the soil, was established at great cost and effort by the various test groups involved in this operation.

Altogether, four experimental field releases from four shots were involved in the Operation. Two shots were conducted in the open with a difference in the ratio of plutonium to high explosive, and the other two were in a storage configuration with the same ratio of plutonium to high explosive but with a difference in the depth of earth overburden on the storage structures.

The experimental arrays were elaborately instrumented for the detection of airborne plutonium and deposited plutonium. A heavily instrumented wire curtain, 1500 ft in width and for one shot 1800 ft in height, was used to document the vertical distribution of plutonium in the cloud. On one of the events a total of 298 animals (84 beagle dogs, 84 burros, and 130 sheep) were positioned in the downwind instrumented array.

These elaborate field experiments developed a great mass of data and resulted in a large number of published reports^{6,7} on the various projects. It is clear, however, that additional efforts should be devoted to an analysis and correlation of this data.

It should be noted that over the intervening years the Reynolds Electrical and Engineering Company has periodically resurveyed the areas that were contaminated by these experiments.

The wisdom and foresight of the authorities who decided to conduct the field release experiments were validated by the Palomares and Thule accidents. In the first place, and of the utmost importance, the bombs that did explode as a result of the accidents did not give a nuclear yield. Secondly, the experiments created a group of people within the AEC and DoD communities with an understanding of, and a thought-out position on, the problem. Fortunately, one member of this group, Wright Langham, Los Alamos Scientific Laboratory, was brought in as a DoD consultant on both accidents. It was primarily through his efforts that this country was able to arrange satisfactory agreements with both the Spanish and Danish authorities. Basically, the operative procedure was to make available to the Spanish and Danish authorities the resources required for them to assure themselves, and consequently their people, that the hazards had been

properly evaluated and eliminated. Published papers by personnel of both countries have indicated that such is indeed the case.⁸⁻¹¹

The Palomares accident on January 16, 1966, resulted from a mid-air explosion during a refueling operation between a B-52 bomber and a KC-135 tanker. Four plutonium-bearing nuclear weapons were jarred loose from the plane by the explosion. Three of the devices impacted on the ground in the vicinity of the Spanish village of Palomares and one landed in the Mediterranean Sea. Two weapons were ultimately recovered intact, the one from the sea and one of the three that impacted on the ground. The other two weapons detonated on impact with the ground and dispersed plutonium over some 1200 acres of ground. A wind with an estimated velocity of 30 knots prevailed at the time. It should be noted that under these conditions the radius of the area with contamination over $500 \mu\text{g}/\text{m}^2$ was about 80 m for one detonation site and about 65 m for the other site. The cleanup procedure consisted of scraping and removing the top layer of soil from about 6 acres with contamination levels above $500 \mu\text{g}/\text{m}^2$. Crops, in fields with contamination levels above $5 \mu\text{g}/\text{m}^2$, were removed and destroyed. All of this material was packaged and ultimately shipped to the United States. Originally, it was planned to plow only the land between the $50 \mu\text{g}/\text{m}^2$ and $500 \mu\text{g}/\text{m}^2$ contamination contours. However, with equipment on hand, it was decided to plow to a depth of about 10 in. all the land contaminated to a level above $5 \mu\text{g}/\text{m}^2$. It was considered that the plowing would dilute the plutonium by mixing it with a greater mass of soil and would make the plutonium less available for resuspension. As previously noted, the Spanish authorities have reported that after the area was decontaminated the air concentrations in the vicinity were those to be expected from worldwide fallout and that all determinations for plutonium uptake on the part of the inhabitants of Palomares had been negative.

The crash of a B-52 bomber on the ice of North Star Bay about 7 to $7\frac{1}{2}$ mi from Thule, Greenland, occurred on January 21, 1966. Cause of the crash was an uncontrollable onboard fire that made it necessary for the crew to bail out. The plane impacted on the ice with a velocity of about 500 knots and at a 15 degree attitude. On impact, the fuel ignited and the four plutonium-bearing weapons exploded. Debris and flaming fuel, propelled by the forward motion of the plane, was scattered along a path about 700 m long. A large blackened area about 130 m wide and 700 m long was formed by combustion products being trapped in refrozen ice and snow. It has been estimated that approximately 99% of the plutonium within the defined contaminated zone was contained in the black crusted ice and snow of this area. Road graders windrowed the black material and mechanized loaders placed it in large wooden boxes for removal from the contaminated area. Eventually sixty-seven 25,000-gallon fuel containers were filled with this material and four additional such containers were required to store contaminated equipment and gear. This material was shipped to the United States for final disposal.

A cloud formed by the explosion was measured by radar as being about 850 m high, 800 m in length, and 800 m in depth, and it undoubtedly carried some plutonium downwind.

Danish scientists investigated rather thoroughly the levels of the plutonium in the environment and concluded from their findings that the environmental impact was negligible.

Two important points that should be remembered are demonstrated by the experience from these two accidents. First, the dispersal of appreciable quantities of plutonium did not create a catastrophe in terms of human impairment and death or in terms of property damage but, instead, were incidents that, with modern technology, were brought under rather complete control. Secondly, the determination to assist the local authorities in their evaluation of the situation made it possible for them to convince themselves that humans had not been injured by the immediate effects and that long-range hazards had been eliminated or reduced to acceptable levels. This assurance was conveyed to their citizens and appreciably reduced the strain on our international relations.

I would sincerely hope that our own citizens would be treated with the same consideration and respect in the event of a similar incident on United States soil. I have instead, however, a very unhappy vision of such an event, in which the news media are on an anti-establishment kick, security and atomic energy experts indulge in individual ego trips, and credibility is completely destroyed, with the final result being a group of citizens unhurt and unendangered, but compelled to carry a psychological burden of worry, fear, and doubt for the rest of their lives. That may be an unduly pessimistic vision, but it does seem clear that positive steps should be taken to identify the best possible response to an accident involving plutonium.

A suggested first step would be to fund a serious effort

- To compile and evaluate available data from the field releases and the accidents.
- To provide an unclassified and realistic evaluation of the hazards associated with an accidental plutonium release to the environment.
- To identify those areas that require funding for immediate and long-range investigations.

A realistic evaluation would in large measure offset the harm that has been done by the misapplication of the "maximum credible accident" concept, and would help to define plutonium's proper place in the spectrum of hazards that confront man in a modern industrial society. If this is not accomplished, and plutonium is compelled to occupy a unique position completely outside this spectrum, then very likely the ultimate judgment will be that science and technology have again been mismanaged. The dissatisfaction with science today stems basically from

our apparent inability to realize the benefits of technology without undue impairment to our physical, environmental, and social well-being. It has been demonstrated that the benefits of plutonium can be realized with minimum adverse impacts on our society. Forcing plutonium out of the marketplace by unnecessary restrictions will only encourage and prolong dependence on materials that have had in the past, and probably will continue to have in the future, severe detrimental effects on society.

References

1. James H. McBride, *The Test Ban Treaty*, Henry Regnery Co., Chicago, Illinois, (1967).
2. Plutonium Environmental Studies Program, Reynolds Electrical and Engineering Co., report in preparation.
3. William S. Johnson, "Report of Fallout Study of January 1956, S6 Project NTS," Los Alamos Scientific Laboratory Report LAMS-2033 (June 1956), (Classified).
4. P. S. Harris, E. C. Anderson, and W. H. Langham, "Contamination Hazard from Accidental Non-Critical Detonation of Small Atomic Devices," Los Alamos Scientific Laboratory Report LA-2079 (September 1956), (Classified).
5. J. D. Shreve, Jr., "Operation Plumbbob—Test Group 57, Report of Director Test Group 57," Sandia Corporation, Albuquerque, NM, Report ITR-1515 (April 1958), (Classified).
6. J. E. Shreve, Jr. and D. M. C. Thomas, "Operation Roller Coaster; A Joint Field Operation of the Department of Defense, the Atomic Energy Commission, and the United Kingdom Atomic Energy Authority (AWRE); Scientific Director's Summary Report," (Classified).
7. K. Stewart, "Roller Coaster, Summary Report," United Kingdom Atomic Energy Authority Report AWRE No. T6/69 (July 1969), (Classified).
8. Emilio Iranzo and Sinesio Salvador, "Inhalation Risks to People Living Near a Contaminated Area," Junta de Energia Nuclear, 2nd International Congress of the International Radiation Protection Association, Brighton, England, (May 3-8, 1970).
9. Eduardo Ramos Rodriguez, "Palomares - Two Years After," (April 1968).
10. USAF Nuclear Safety, AFRP 122-1 Jan/Feb/Mar/1970, No. 1, Volume 65 (Part 2), Special Edition Project Crested Ice.
 - Danish Thule Committee, "Evaluation of Possible Hazards," pp. 8-11.
 - Jorgen Koch, "Danish Scientific Group Investigations," pp. 42-44.
 - Henry L. Gjorup, "Investigation and Evaluation of Contamination Levels," pp. 57-63.
 - Christian Vibe, "Ecological Background," pp. 64-69.
 - F. Hermann, "Ecology Survey," pp. 70-73.
 - Asker Aarkrog, "Radio-Ecological Investigations," pp. 74-79.
 - Walmod Larsen, "Danish Health Physicists' Activities," pp. 80-81.
11. A Aarkrog, "Radioecological Investigations of Plutonium in an Arctic Marine Environment," Health Physics, Vol. 20 (Jan. 1971), Pergamon Press, pp. 31-47.

INDUSTRIAL-TYPE OPERATIONS AS A SOURCE OF ENVIRONMENTAL PLUTONIUM

by

S. E. Hammond
The Dow Chemical Company
Rocky Flats Division
Golden, Colorado 80401

ABSTRACT

From 1953 through 1970, the Rocky Flats plant has released upper limits of 41 mCi of plutonium as airborne effluents and 90 mCi of plutonium through liquid effluents. Methods and limitations of these measurements are described.

In addition to these controlled releases, accidental releases to the environment occurred during a fire in 1957 and from wind transference of contaminated soil prior to 1970. These incidents are described and estimates of amounts of plutonium involved made by various investigators discussed.

The Rocky Flats plant began operating in 1953 processing plutonium, enriched uranium, and depleted uranium. Over the years more and more emphasis has been placed on plutonium and less and less on the other materials. Since this is a plutonium meeting, we will confine our discussion to plutonium operations at Rocky Flats.

Figure 1 is a map of the area in which we are located. The AEC-owned land is 2 miles on a side with the occupied portion of the plant site confined to about 1 square mile in the area between Walnut Creek and Woman Creek. Downtown Denver is about 15 or 16 miles to the southeast. The southern city limits of Boulder, a city of 70,000, lie 6 miles north. The other towns shown are smaller. This area is essentially greater Denver and urban. The area close to the plant is rural - mainly grazing land although there is some irrigated farming. Plans exist for commercial and residential development close by, mainly to the south and east.

The southern portion of the plant site is drained by Woman Creek, dry part of the year, which flows into Standley Lake. Standley Lake is an irrigation reservoir as well as the municipal water supply for Westminster. The northern portion of the plant is drained by two branches of Walnut Creek which join east of the plant and flow into Great Western Reservoir. Great Western Reservoir is Broomfield's municipal water supply. Effluents from our process waste treatment plant and from our sanitary

sewer system flow into the south branch of Walnut Creek and through a series of four ponds before release offsite. Walnut Creek provides about 2% of Great Western's water, another 8% comes from Coal Creek, and the remaining 90% from the Clear Creek watershed.

The foothills of the Rocky Mountains extend along the west edge of Fig. 1; the remaining terrain is typically

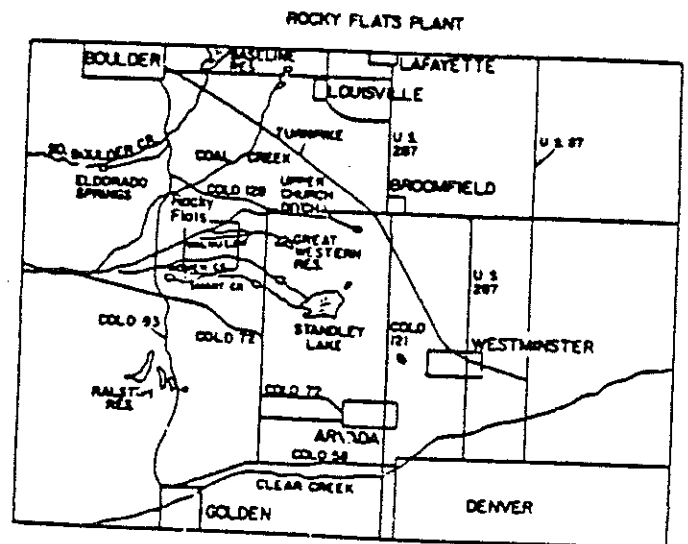

Fig. 1

prairie - arid and sparsely vegetated except where it is irrigated. The government-owned land is enclosed with a barbed wire cattle fence; there are no domestic animals within its boundaries. Wildlife which shares our domain includes such typical prairie types as deer, coyote, rattlesnakes, and rabbits.

Winds from the west, northwest, and southwest prevail along the foothills. During the fall and winter months windstorms occur frequently. Gusts over 100 mph have been recorded. The prevailing winds at the Denver weather station are from the south.

Preoperational site-survey measurements were conducted by a team from Hanford and included beta-gamma surveys, and water and vegetation samples analyzed for uranium plus plutonium content, plus a few radium measurements.

Figure 2 is a close-up of Rocky Flats. This figure shows our original plutonium processing facility, building 771, and process waste treatment facility, building 774. More recent additions to the plant include buildings 776-777, a production building completed in 1957, building 779 R and facilities completed in 1966, building 559, an analytical laboratory completed in 1968, and building 707, a production building completed in 1971. We refer to this entire area as the plutonium complex. Plutonium operations are confined to this area for the most part. The

903 area was used as a temporary storage area for drums containing contaminated oil for a time. We will discuss this more later.

All effluent air from plutonium buildings is filtered through HEPA filters and stacks are continuously monitored for airborne releases. Isokinetic samples are collected through HV-70 paper and evaluations are calculated in terms of total long-lived alpha. Initially, when we believed that all releases were of PuO_2 , we applied the guide level of 1 pCi/m^3 for insoluble plutonium. Now, rather than demonstrate proportions of insoluble and soluble plutonium in typical effluents, we apply the more restrictive soluble guide of 0.06 pCi/m^3 for soluble plutonium to all stack releases.

Figure 3 shows the location of our 12 onsite air samplers. These are continuous samplers drawing 2 cfm and are collected daily. Total long-lived alpha evaluations of these samples have always been well below the plutonium guide levels. Figure 4 shows typical data from the onsite sampling net. This particular display is for 1968 and 1969 and is no different from earlier years.

We believe that additional filtration, advanced design features, and more exhaustive treatment of liquid wastes, some already completed and some yet to be completed, will place us in a position of near zero release within the next few years.

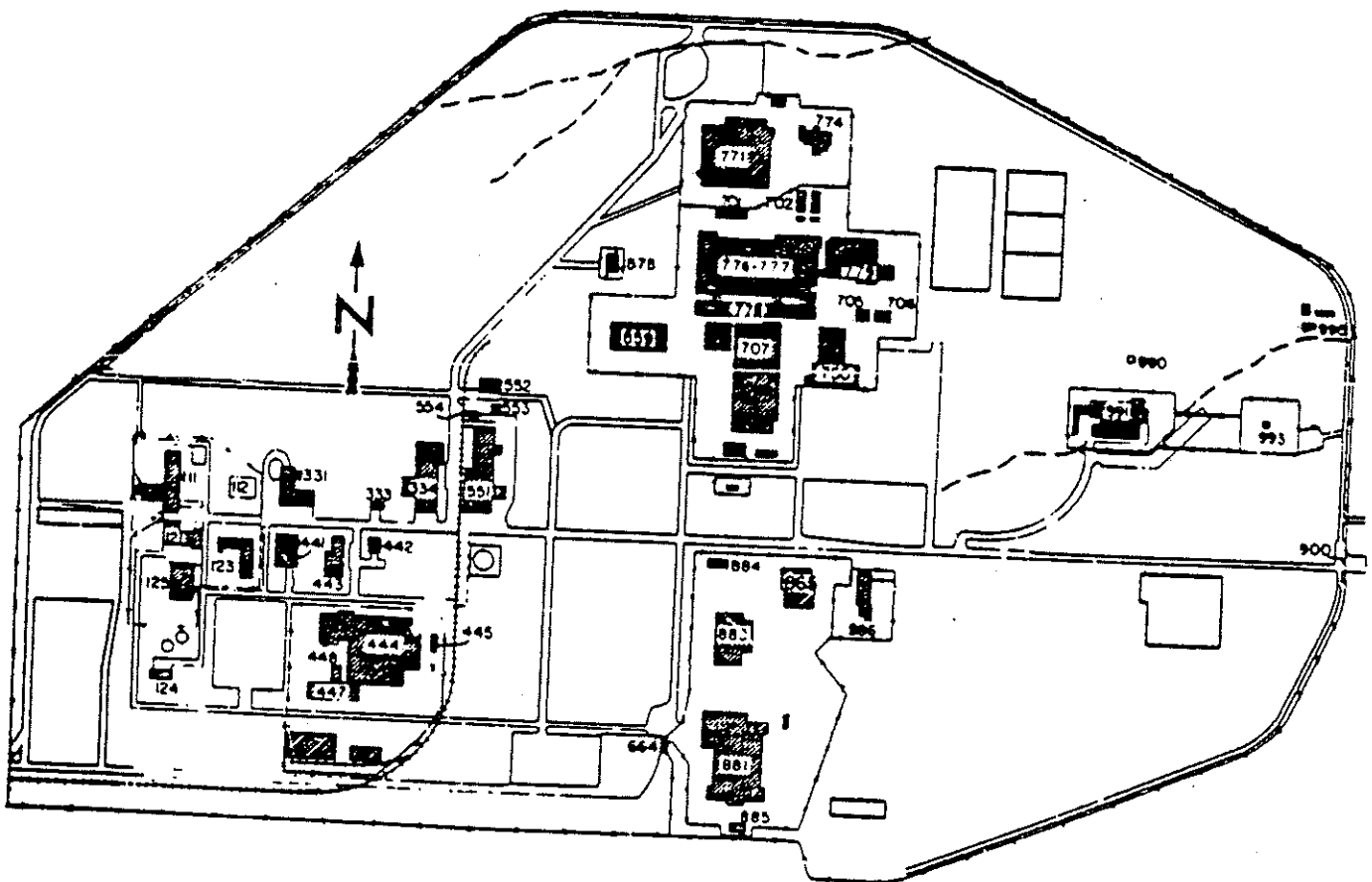

Fig. 2

ROCKY FLATS PLANT

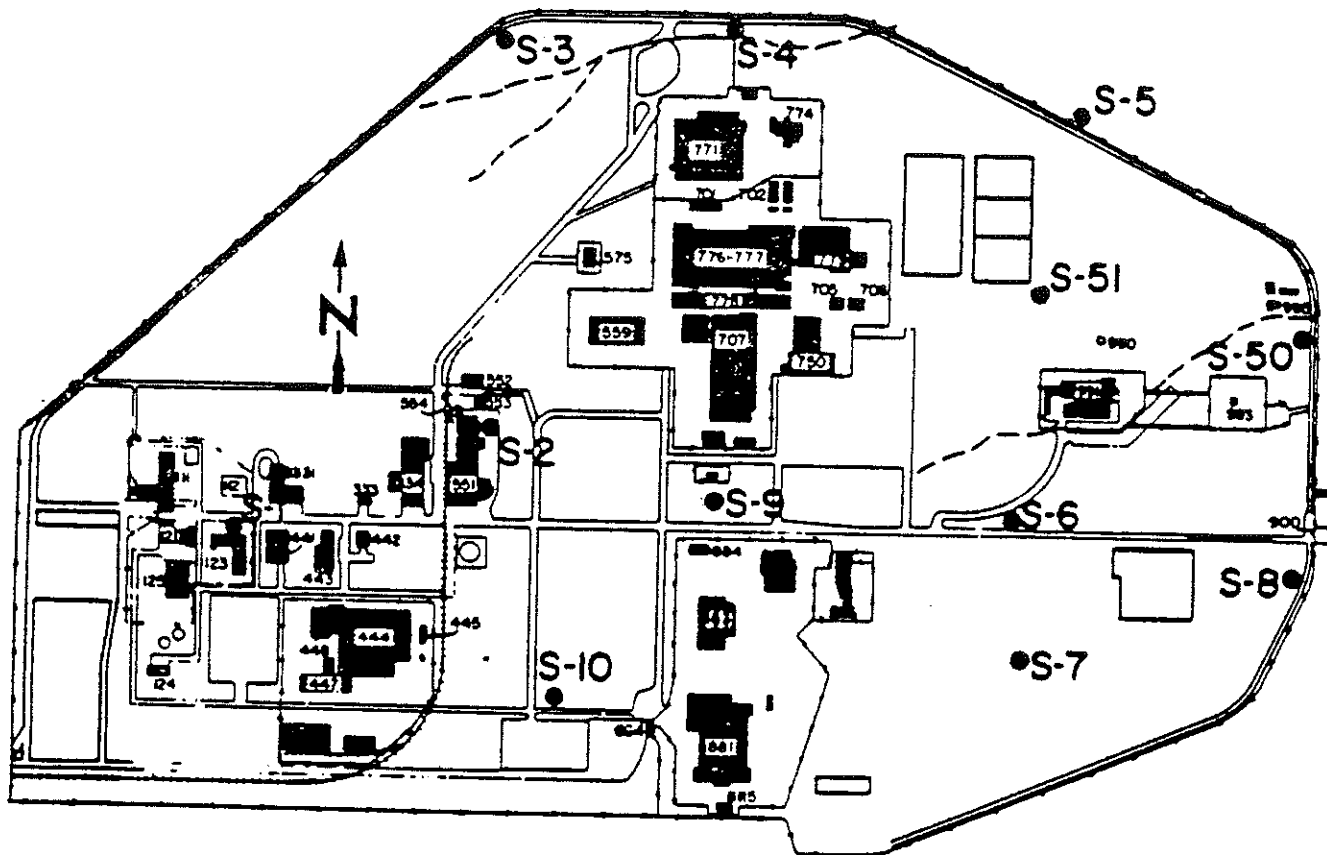

Fig. 3

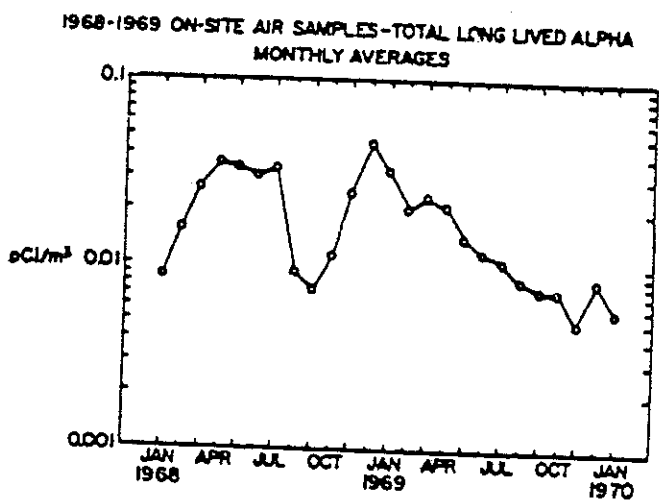

Fig. 4

Figure 5 shows average total, long-lived alpha concentrations measured in the building 771 main exhaust. This particular building typically shows greatest operational releases. The graph indicates both yearly averages as well as the range of monthly averages in pCi/m^3 . The high point in 1957 occurred following a fire that damaged the filter system. The high points of 1964 and 1965 were attributed to filter leakage occurring about the middle of December, 1964 and corrected in the latter part of January, 1965.

Figure 6 shows total stack release by year from our plutonium complex. The data are expressed as μCi of total long-lived alpha. The high concentrations seen in Fig. 6 are the 1957 fire and building 771 filter failure in 1964 and 1965. The 1957 peak does not represent total release during the fire since our sampler became inoperative during the fire. Rather it is an indication of high samples observed in October, 1957 from contamination in the ductwork and plenum following restoration of the system. The peak in 1969 is due to higher samples from building 776 following the May 1969 fire. Figure 7 depicts integrated airborne releases through the stacks and totals $41.3 \mu\text{Ci}$ of total, long-lived alpha through April 1971.

Waste solutions generated in the plutonium complex include laundry wastes and process waste solutions generated at various phases of the operations. Such

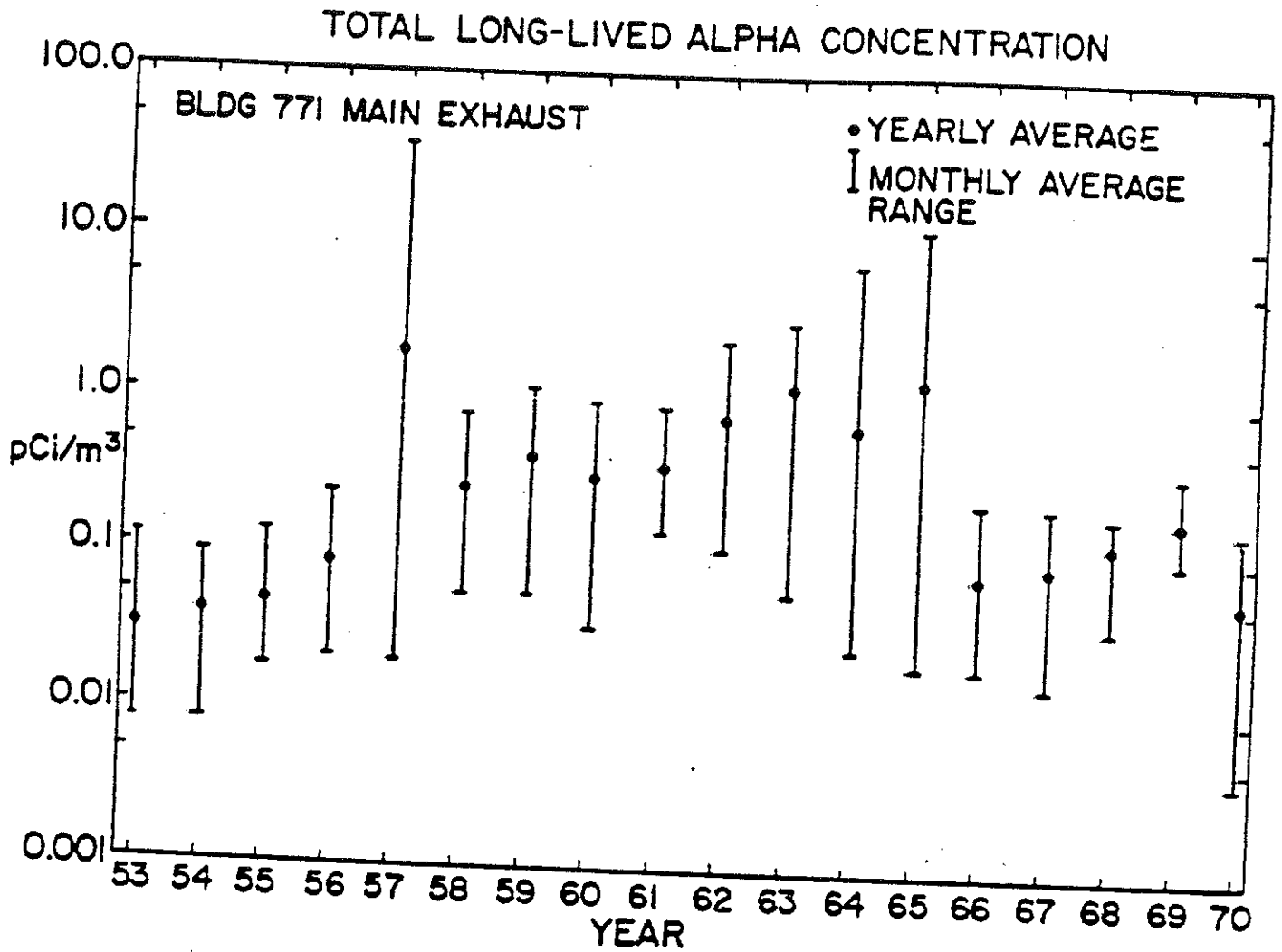

Fig. 5

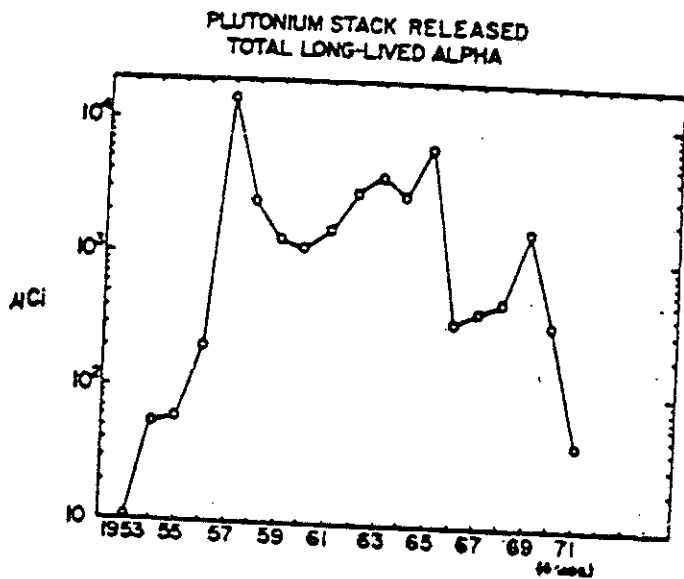

Fig. 6

solutions are held in storage tanks at their generation point until they have been analyzed, at which time several options exist. Solutions which are low in plutonium content but high in chemical content may be pumped to solar evaporation ponds for concentration. Solutions which meet USPHS drinking-water standards in chemical content and 10 CFR 20 standards in radioactive content may be released to the sanitary waste system. Using the same rationale as with airborne effluents, we apply the most restrictive guide of our plant materials, 1600 pCi/liter for soluble plutonium, as our release point. Other solutions are pumped to building 774, our waste treatment facility, for further plutonium removal. Solids resulting from building 774 operations and other solid plutonium-containing wastes generated in other buildings are packaged and shipped to Idaho for burial and storage. There have been no known plutonium releases to the environment by way of solid waste handling.

Liquid effluents from building 774 are released to the south Walnut Creek course when they meet USPHS and 10 CFR 20 guides. This effluent joins with sanitary sewage effluent and flows through a series of ponds into

INTEGRATED AIRBORNE LONG-LIVED ALPHA ACTIVITY

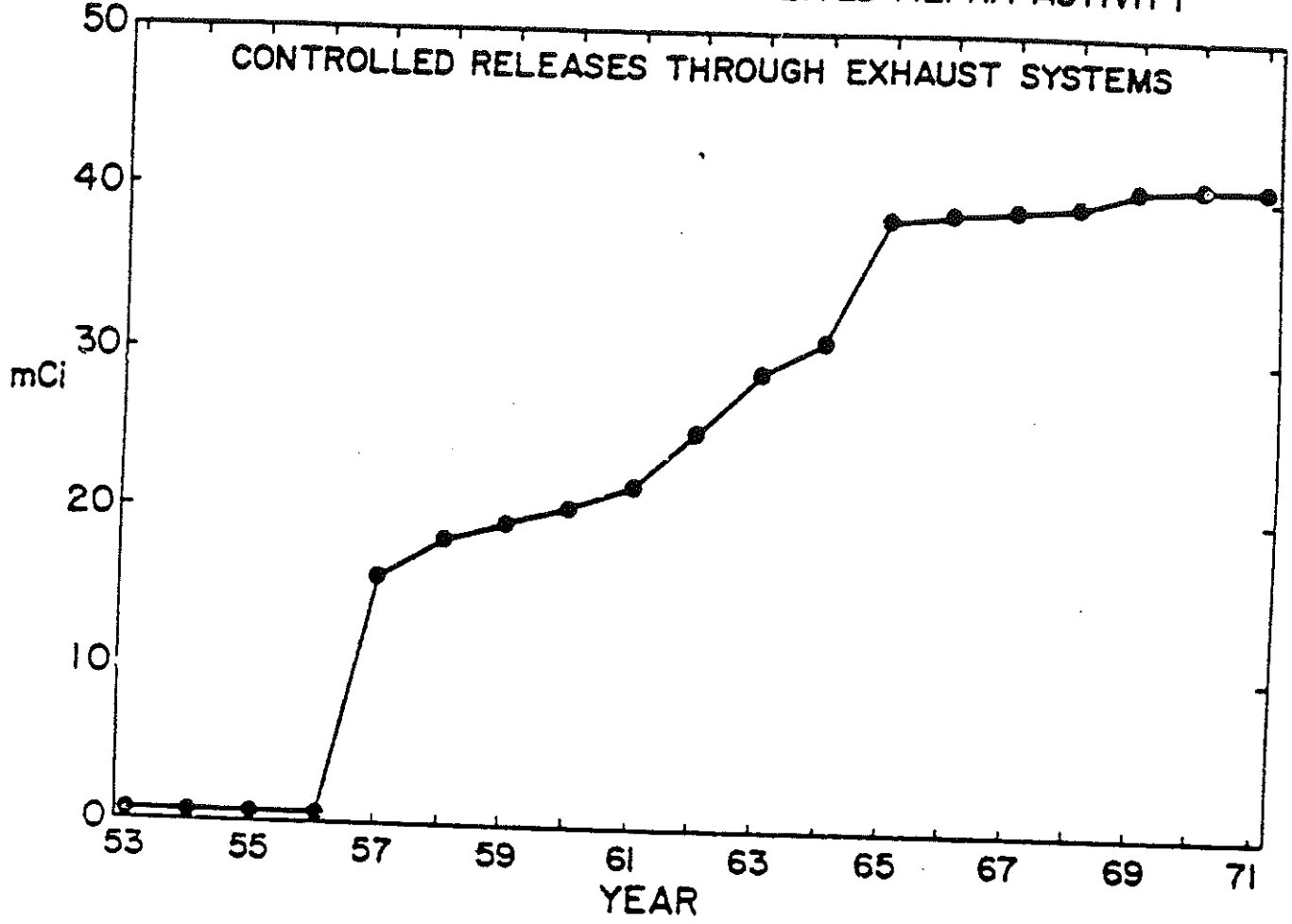

Fig. 7

Great Western Reservoir. Figure 8 shows ponds 1 on north Walnut Creek, 2 through 5 on south Walnut Creek, and 9 on Woman Creek. Ponds 1, 5, and 9 serve as monitoring ponds. Ponds 1 and 9 are grab-sampled daily and samples composited for a weekly analysis. Pond 5 outflow is sampled continuously by a proportional sampler and analyzed weekly. Following the lead of the Hanford preoperational site survey team we performed a so-called gross alpha analysis on these samples for many years. The analysis actually is specific for uranium and plutonium and separates out other alpha emitters. The most restrictive guide, for soluble plutonium, has been applied to the gross alpha activity. Now we also analyze these gross alpha samples by alpha spectrometry to determine specific plutonium content as well. Figure 9 shows the gross alpha content of pond 5 effluent. This value includes natural uranium found in Colorado waters. The upper line is the maximum sample found in a year, the bottom line the yearly average. As a comparison with plutonium concentration our 1970 measurements averaged 2.8 pCi/liter plutonium with a maximum single sample of 8.6 pCi/liter.

Figure 10 shows the integrated amount of gross alpha activity released through pond 5 to be 88.5 mCi.

Prior to the addition of building 778, the plutonium laundry was located in building 771. Laundry waste samples lower than 1600 pCi/liter were released directly to the north branch of Walnut Creek. An additional 2.5 mCi of activity has been released to the environment by this route, or a total of 91 mCi in liquid effluents. An undetermined portion of this 91 mCi is naturally occurring.

In addition to controlled releases, plutonium has been released to the environment from three occurrences.

In September, 1957 plutonium metal spontaneously ignited in a glovebox and several kilograms burned. The fire quickly burned through the Plexiglas window. After unsuccessful attempts to control the fire with CO₂, a fine spray of water was used successfully. Large amounts of smoke had filled the room and the exhaust fans were turned on high speed to clear the smoke. This smoke was plainly visible as it left the stack. However, portable air samplers set up to monitor this smoke detected very little long-lived activity.

The fire next spread up the exhaust ducts to the exhaust filter plenum. Flammable filters soon caught fire destroying a major portion of the filtering system. This spread of fire was accompanied by an explosion in the exhaust duct.

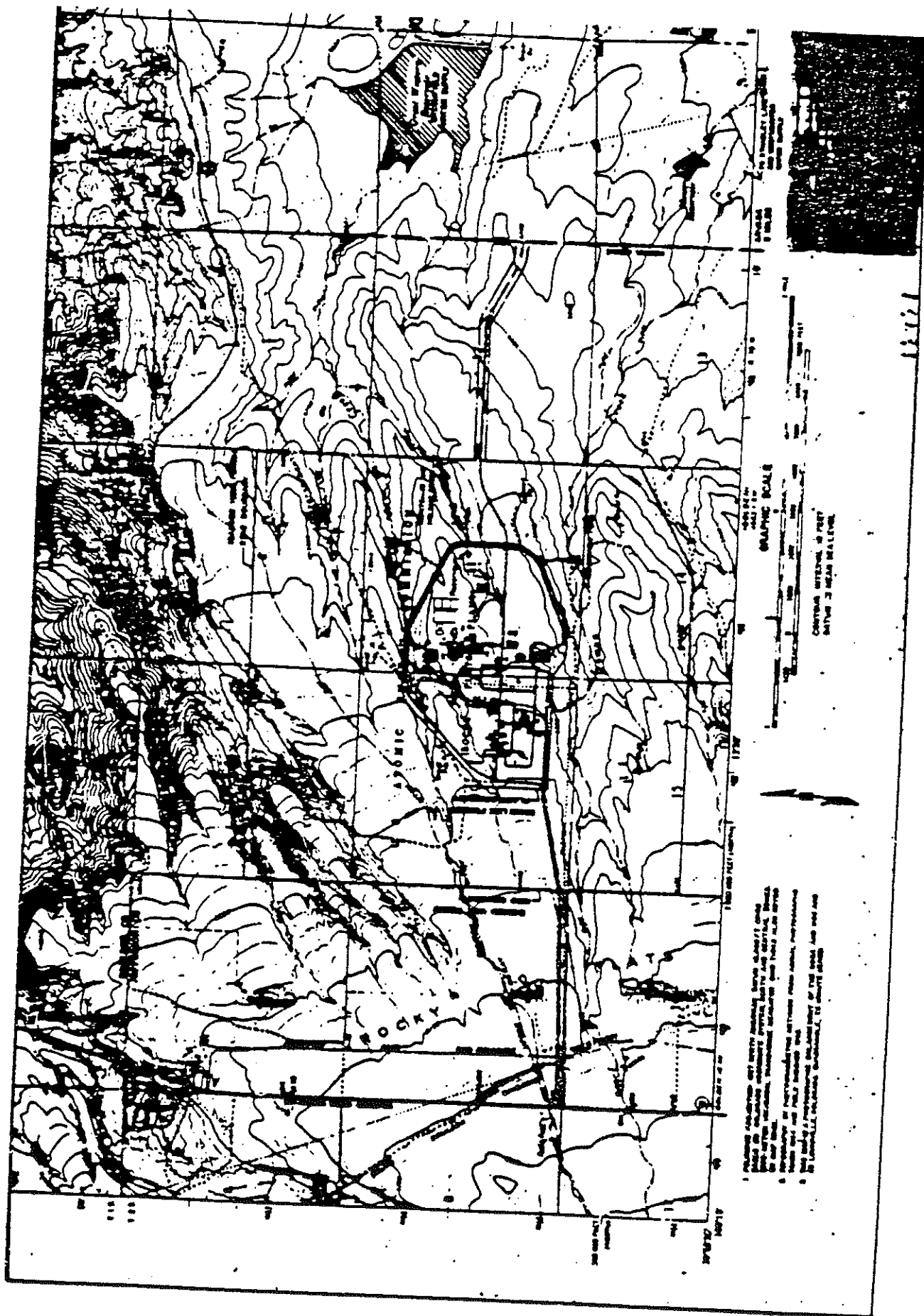

Fig. 8

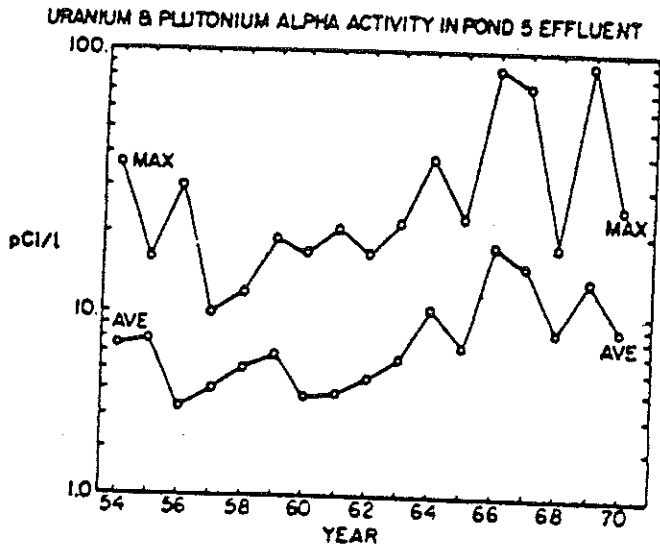

Fig. 9

Following the fire it was estimated that about 1 g of plutonium had been released offsite through the damaged filter system.

Figure 11 is the alpha spectrum of a 15-min, high-volume air sample taken downwind (south) during the fire. It indicates a concentration of about 4 pCi/m³ Pu. Another sample taken due east of the stack showed barely detectable amounts of plutonium.

An environmental survey was begun the following day with a pickup of vegetation, soil, and water samples. The soil analyses were not very definitive. We acid-leached them and separated plutonium by our then-routine method of bismuth phosphate-lanthanum fluoride coprecipitation. While we could detect plutonium by alpha spectrometry in some of the onsite samples, there were other alpha emitters present, the spectra were smeared, and we were unable to quantify the results.

Of some 15 onsite water samples collected, plutonium was detected in four of them at a maximum of

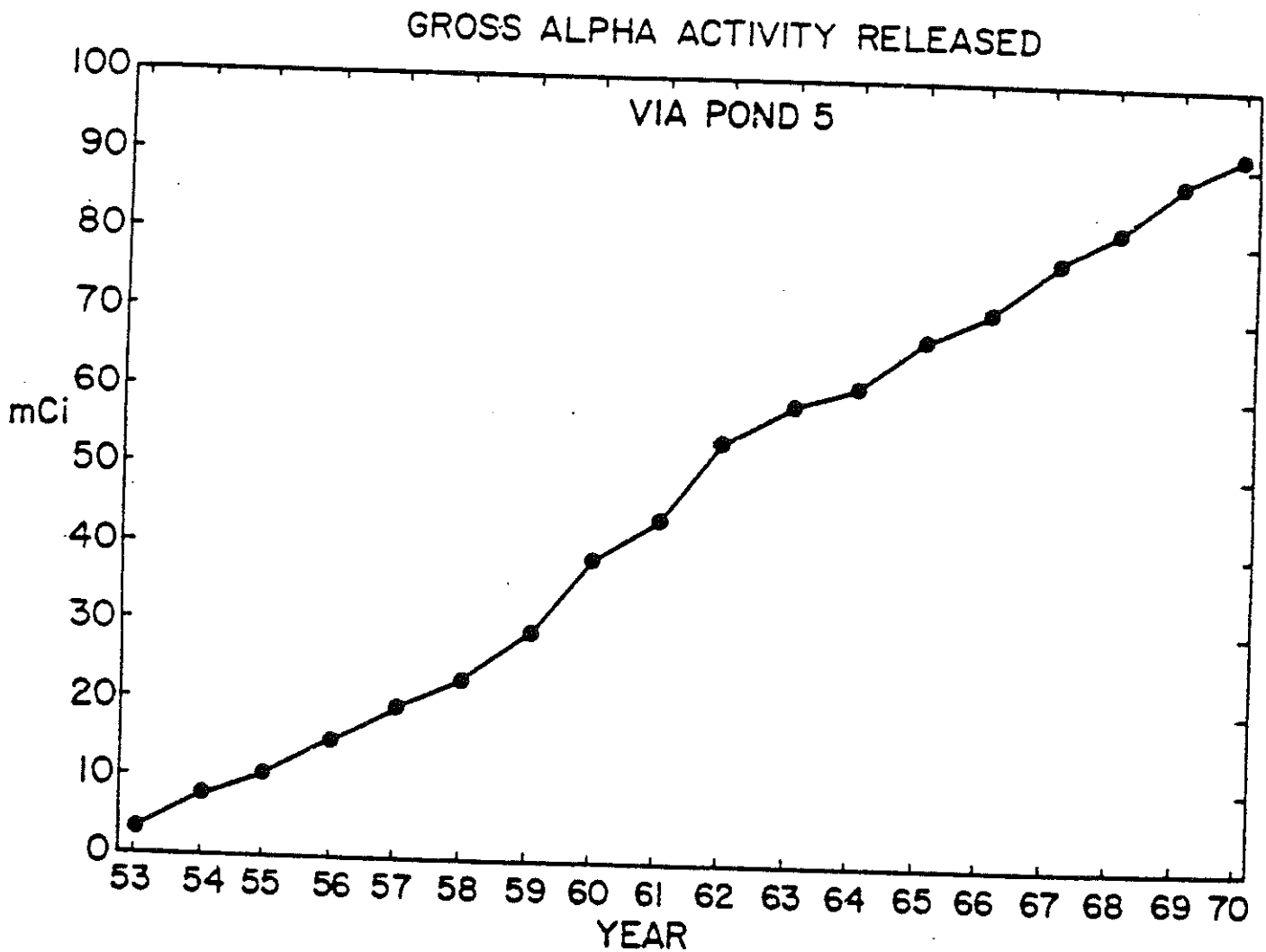

Fig. 10

HIGH VOLUME AIR SAMPLE 9-11-57

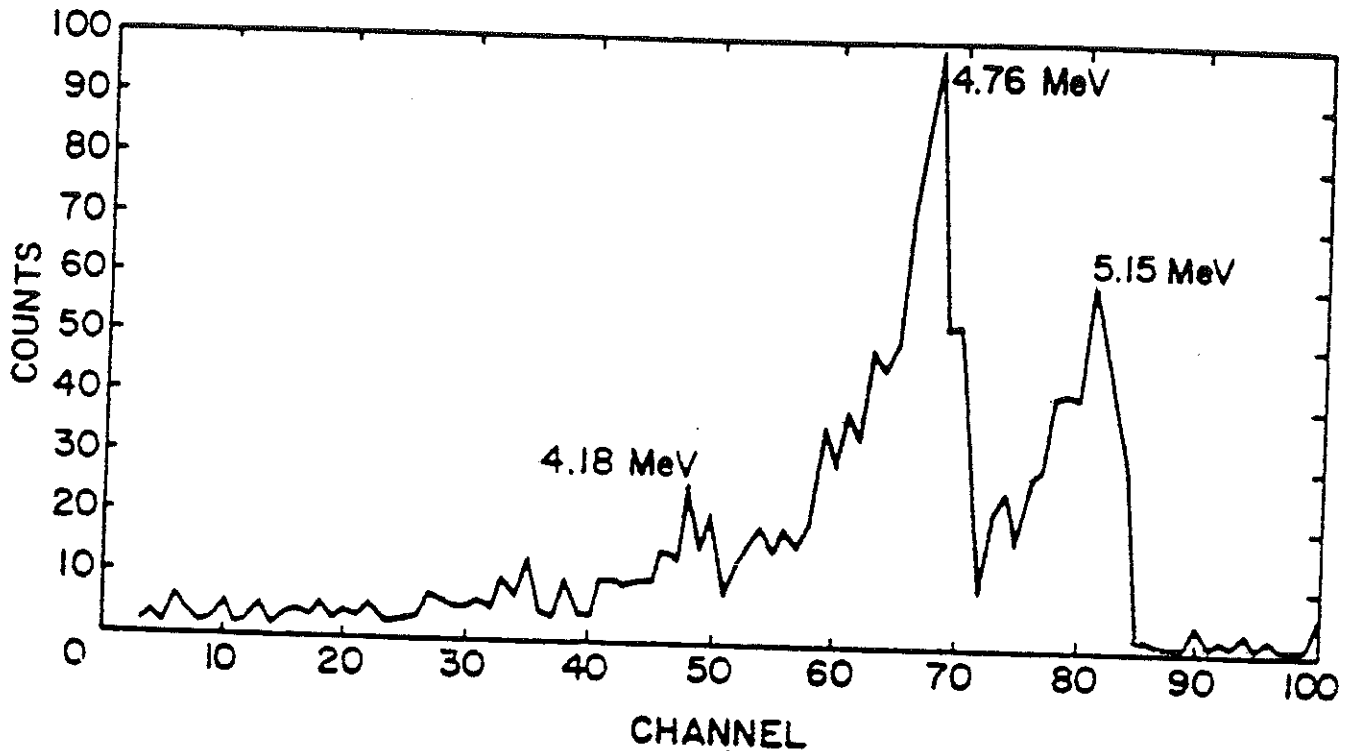

Fig. 11

0.5 pCi/liter. Of 35 offsite water samples collected during the month following the fire, plutonium contamination was noted in two of these at a level too low to be statistically valid—less than 0.1 pCi/liter.

Water and vegetation samples were analyzed by extracting with ether at that time. This method gave good separation of plutonium and uranium and a thin mount for alpha spectrometry. Figure 12 is a typical alpha spectrum of a vegetation sample. We detected plutonium on most of the vegetation samples collected during this period up to a maximum of 600 pCi/kg on 47 onsite samples and 200 pCi/kg on 43 offsite samples.

Our alpha spectrometer had only recently been acquired and we had no pre-fire data on plutonium on vegetation. Consequently we were unable to estimate how much of the observed plutonium was of fire origin. We saw some plutonium on samples taken from all directions from the plant but the maximum were to the south, downwind at the time of the fire. The gross alpha activity of these samples was somewhat higher than our background data although not extremely so. We could not detect any ground contamination on the plant site by direct survey. We concluded from these measurements that any offsite contamination resulting from the fire was insignificant and there were no hot spots from fallout from the stack.

On May 11, 1969, a fire broke out in building 776 and eventually resulted in multimillion dollar damage.

Although there was some damage to one filter plenum the building essentially maintained its integrity and little plutonium escaped. Contamination was found on the roof of building 776 and an adjacent building and on the ground on three sides of building 775. The roof contamination, up to 10^6 CPM as measured with survey instruments, came from booster 1 exhaust. Most of the ground contamination was caused by tracking during fire-fighting operations. Levels up to 10^5 CPM were noted on the ground. Onsite air samples for the period May 9 through 12, 1969 ranged from 0.03 to 0.31 pCi/m³ total long-lived alpha. This is higher by an order of magnitude than we normally observe but still well below the guide level for insoluble plutonium. Offsite air samples showed no observable elevation of alpha activity. This was also confirmed by the state of Colorado Department of Health on samples taken from their monitoring net. The wind was low and mostly from the northeast during the fire.

Because of re-entry problems we were unable to retrieve our exhaust samples until May 15. The three samples in the main exhaust showed 3.2, 21.6, and 35.0 d/m/m³ total long-lived alpha for this period. From these data we calculated a maximum release via the main exhaust of 193 μ Ci during the 144-h period of May 9 through 15. Booster and dry air systems samplers shut down about 4 p.m. on the day of the fire due to power loss. Through that period of time they had released 13 μ Ci of Pu. Therefore, release from the exhaust system was somewhat in excess of 206 μ Ci (3.3 mg).

V O, 2E 10-10-57

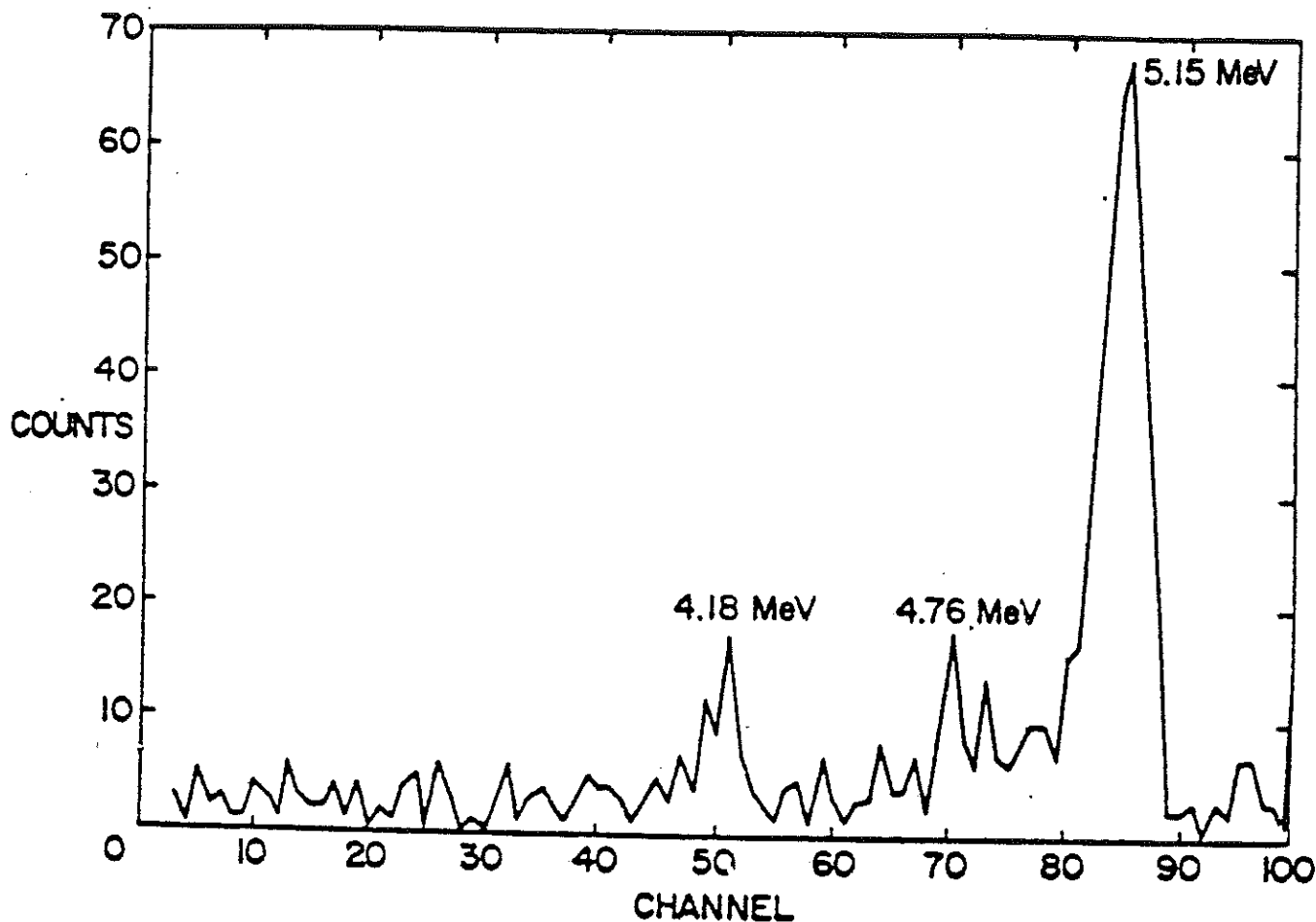

Fig. 12

Liquid effluents showed a maximum level in pond 5 on May 12, 1969 of 88 pCi/liter gross alpha and 12 pCi/liter in Walnut Creek near Great Western Reservoir. During the month of May, daily samples of Great Western Reservoir showed a maximum of 5 pCi/liter gross alpha which is not elevated from normal readings.

Vegetation samples analyzed radiochemically for plutonium ranged up to 225 pCi/kg of plutonium. The uranium plus plutonium alpha content of these same samples showed no anomalies from our routine environmental sampling program results in prior years.

As this information was gradually made public, the Colorado Committee for Environmental Information (Peter Metzger, Chairman) and a Rocky Flats subcommittee of this group under Ed Martell took issue with our conclusions that no significant amounts of plutonium had been released during the fire. At a meeting at Rocky Flats the subcommittee argued that our air sampling net was not adequate to detect a channelized release, that vegetation was not a good sampling medium, that a land survey for localized "hot spots" should be conducted, that our water data showed a plutonium buildup in Ralston Reservoir, and that soil samples should be collected and

analyzed for plutonium. We took issue with some of their points but did agree to conduct a limited soil sampling program. We collected some 50 soil samples in August, 1969 but postponed analyzing them or even developing an analytical method for them until we had completed our other environmental samples. In the meantime Ed Martell and Stewart Poet collected soil and water samples in the area and analyzed them in their laboratory at NCAR in Boulder. Martell disclosed his data in January, 1970 in a letter to Glenn Seaborg. Soil samples from 15 locations mostly east of the plant ranged from 0.04 d/m/g (his background sample) to 13.5 d/m/g of plutonium and seven water samples from 0.003 to 0.4 d/m/liter of plutonium. Soil and water samples we had completed by that time were in general agreement with his data.

The AEC sent Ed P. Hardy and Phil W. Krey from NYO HASL to conduct an independent study of plutonium contamination in the area in February, 1970. Their findings are summarized in HASL-235 (August, 1970). They sampled 33 sites up to 40 miles distance from the plant and found concentrations ranging up to 2000 mCi/km² (40 d/m/g) offsite. Using a 3-mCi/km² contour as their lowest readily discernible contour

(approximately 2 times background from worldwide fall-out) they concluded the contamination from Rocky Flats extended east and southeast up to 8 miles and contained 2.6 Ci (41.6 g) of plutonium excluding AEC-owned land.

The state of Colorado Department of Health also conducted a survey of plutonium in surface soils offsite. They composited 25 surface samples from each of 13 segments. SWRHL analyzed these samples and found a maximum of 24 d/m/g. From these data the Colorado Department of Health estimated 0.3 Ci (4.8 g) of plutonium as surface contamination offsite.

Using additional data, a group of Dow R and D people estimated offsite surface contamination to be 7.6 g of plutonium.

Although Martell had developed his study because he believed the May, 1969 fire had released large amounts of plutonium, it was soon apparent that the source of contamination was not the fire but from a contaminated area onsite, the 903 area previously mentioned.

In the late 1950's plutonium processing began generating large quantities of contaminated cutting oils and solvents. These could not be shipped as contaminated waste nor processed at the waste treatment plant. While technology for handling these wastes and administrative decisions pursuant were being developed, drums of the liquids were stored in a field beginning in 1958. Initial plans called for transporting the drums to the waste treatment facility for processing as soon as necessary equipment was installed. Rust-retardant had been added to the drums; however, in 1964 it was determined that it would be necessary to transfer the material to new drums at the storage site. A small building for filtering and transferring the liquids was erected in 1966 and, in 1967, the drum removal began. The last plutonium-containing drum was transferred in January, 1968, and all drums had been removed by June, 1968. Monitoring of the storage area in July noted levels of from 2×10^5 to 3×10^7 d/m/g alpha activity and penetration of the activity from 1 to 8 in. Fill was applied the following year to help contain the activity and the actual area on which barrels had been stored, a 395 by 370-ft rectangle, was covered with an asphalt pad completed in November, 1969. Additional fill was added around the pad in 1970 when soil samples ranging from tens to hundreds of d/m/g were obtained. Soil stabilization studies were started to be applied to the entire area, and a revegetation program was begun.

From material balance calculations it was estimated that about 5000 gal containing 86 g of plutonium (5.4 Ci) had leaked.

We moved one of our onsite air samplers to the security fence just east of the storage area in 1963 to monitor the area. Figure 13 is a comparison of the air sample data from this location with the average of the other onsite air samples from 1963 through 1970. These data are total, long-lived alpha, not plutonium concentrations. Even so, the average concentrations are well below the guide for insoluble plutonium of 1 pCi/m^3 . This

sample station is about 1/2 mi from the nearest plant boundary (which is due east). Even though elevated air samples were observed there was no indication of the extent of offsite contamination occurring.

Referring to the arrows on the figure, from left to right, the first refers to the point in time when drums were first observed to be leaking, the second to a period of high winds following which hot spots were covered with dirt. The next two demark the time of the drum removal operation. The highest point, about $1/3 \text{ pCi/m}^3$, occurred at the time vegetation cover was removed and grading started preparatory to pouring the asphalt pad. The penultimate point at the right indicates completion of the asphalt pad, and the final arrow indicates addition of base course material around the pad.

In summary, then, plutonium releases to the environment attributable to Rocky Flats can be broken down as follows:

1. Controlled Releases	
Airborne effluents	41 mCi = 0.7 g
Liquid Effluents	91 mCi = 1.5 g
2. Uncontrolled releases	
1957 Fire	Maximum of 1 g
1969 Fire	0.21 mCi = 0.003 g
Wind-transferred from drum storage area	300-2600 mCi = 5-42 g

Obviously the most dramatic environmental impact has been from the contaminated dirt transferred by high winds from the drum storage area. However, air-sampling data directly downwind indicates that applicable guides both for occupational exposures onsite and nonoccupational guides offsite have not been exceeded or approached.

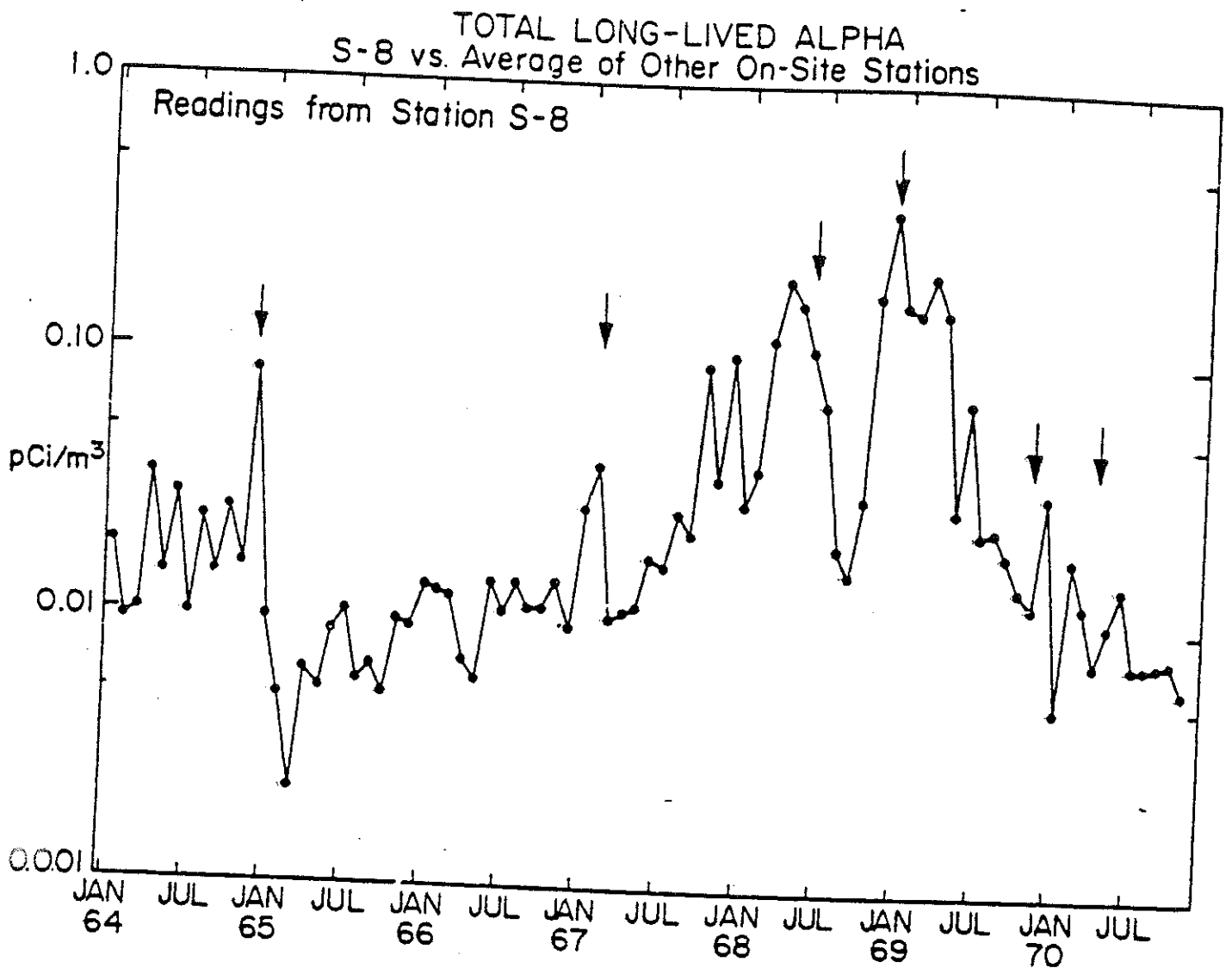

Fig. 13

ROCKY FLATS PLUTONIUM RELEASES

I CONTROLLED		
AIRBORNE EFFLUENTS	0.67 g	42 mCi
LIQUID EFFLUENTS	1.4 g	90 mCi
II ACCIDENTAL		
1957 FIRE	mg up to 1 g	~0.06 Ci
1969 FIRE	3.2 mg	~0.0002 Ci
CONTAMINATED SOIL TRANSFERENCE	~42 g	~ 2.6 Ci

Fig. 14

DETERMINING THE ACCUMULATED DEPOSIT OF RADIONUCLIDES BY SOIL SAMPLING AND ANALYSIS

by

E. P. Hardy and P. W. Krey
Health and Safety Laboratory
U. S. Atomic Energy Commission
New York, N. Y.

ABSTRACT

Soil sampling and analysis is a feasible way to determine the accumulated amounts of long-lived radionuclides that have deposited on the ground. The Health and Safety Laboratory has measured ^{90}Sr and plutonium isotopes in soil samples to determine global and regional deposition patterns and inventories. Site selection and representivity, sampling, and analytical precision and accuracy are discussed in this paper. It is shown that the precision of replicate aliquoting and analysis is the determining factor in the overall error associated with soil sampling.

Introduction

Since the discovery of plutonium contamination extending outside the Dow Chemical Co. plant at Rocky Flats,¹ there has been a contagious interest in soil sampling. This has come about primarily because of the failure of nuclear plant environmental monitoring systems to detect chronic low-level releases of radionuclides. The practice of relating total alpha or beta activity measurements to the MPC's has been satisfactory from a regulatory standpoint but it has not provided the information that is now demanded. The questions being asked today relate to how much radioactivity from a specific nuclide is getting outside the nuclear plant boundary. For the most part, satisfactory answers have not been given and plant operators have been forced to resort to soil sampling in order to find out, as a first step, how much radioactivity has accumulated in the environment from operations to date.

If adequate air monitoring and radiochemistry were carried out routinely, soil sampling should play only a supplementary role in a monitoring program. Soil is primarily useful as an integrator of initially air-borne long-lived radionuclides that have deposited on the ground. Soil sampling for this purpose is not new to HASL since we have used this method periodically since 1955 to

delineate the global distribution of fallout ^{90}Sr and to inventory the accumulated deposit.^{2,3,4}

Sampling and Preparation

It is easy but tedious to sample soil, and analytical methods are straightforward. The difficulty is in selecting a proper site; a site which represents all of the radionuclide which has fallen-out. This does not mean a site where, by some natural process, the radionuclide is transported horizontally to another spot once it is deposited. In other words, we avoid those areas where accumulation or depletion can occur through such phenomena as flooding or erosion. These kinds of sites are easy to find. All one has to do is sample along the base of a fence, under a large tree, in a drainage ditch, on the side of an ant hill etc. and the results might depict anything except what actually deposited from above. There are conditions where it may be easier to determine what fell out over a 100 km² area than over a one square kilometer area. For example, we can do a global inventory for ^{90}Sr by sampling less than one-tenth of a m² of ground at only 100 sites around the world. It might be considerably more difficult to define local deposition patterns in a desert or mountainous area.

As for soil sampling in a locally contaminated area, HASL demonstrated that the Rocky Flats plutonium could be inventoried by our methods.¹ We were able to describe the contamination pattern as well and showed that it extended about 8 miles east and south east of the plant. We see no reason why our soil sampling techniques could not be applied to any locally contaminated area provided that the contaminant was initially made airborne in micron size particles from the source.

Whenever we talk about deposition of air-borne debris the only meaningful values are expressed in units of activity or amount per unit area. Soil sampling should be carried out in such a way that the actual surface area sampled is known. Then the entire sample is weighed in the air-dried state so that the activity per unit weight of soil measured can be converted to area concentration.

Our sampling and preparation procedures are well documented² but a brief description might be helpful here. We try to find flat grassed sites where we can take at least ten, 3½-in.-diam cores in a straight line, spaced about a foot apart. After drying, the entire sample is crushed and blended. Then, about 3 kg are passed through a pulverizing mill. This is the sample from which aliquots are taken for analysis.

Vertical Distribution of Radionuclides in Soil

Implicit in the above discussion is the need to take the soil sample deep enough so that all of the radionuclide deposited is collected. We know that in time any nuclide initially falling on the surface will migrate downward. The actual extent of vertical penetration will depend primarily upon the soil type, but many other factors are involved such as precipitation amount, chemical form of the nuclide, etc. At Rocky Flats we decided to sample down to 20 cm on the basis of our experience with ⁹⁰Sr. It was fortunate that we did because we found that the Rocky Flats plutonium was measurable to 13 cm. Last fall we took depth profile samples of the sandy soil at Brookhaven and analyzed them for ¹³⁷Cs and ⁹⁰Sr in addition to ²³⁹Pu. Table I expresses our results in terms of the percentages of the total amount deposited for each increment. Cs-137 was measurable down to 21 cm and ⁹⁰Sr and ²³⁹Pu were detected as far down as 25 cm. The point we want to make here, however, is that only 40 to 60% of the total ¹³⁷Cs, ⁹⁰Sr, and ²³⁹Pu from nuclear tests is in the top 7 cm of soil. Similar distribution profiles were found for the Rocky Flats plutonium.¹ If one is interested in measuring all of the deposited radionuclide, we would advise sampling from the surface to 30 cm.

Site Reproducibility

The criteria for selecting a site which represents the accumulated deposit in a particular area have been discussed by Alexander². Dr. Alexander developed the

TABLE I

VERTICAL DISTRIBUTION OF FALLOUT RADIONUCLIDES IN BROOKHAVEN SOIL (FALL 1970)

Depth increment (cm)	Percent of Total		
	¹³⁷ Cs	⁹⁰ Sr	²³⁹ Pu
0 - 7	59	42	57
7 - 11	26	30	27
11 - 15	11	15	11
15 - 21	4	8	3
21 - 25	0	2	1
25 - 30	0	3	1

sampling techniques and did most of the ⁹⁰Sr sampling for HASL when he was with the Department of Agriculture. We have a considerable body of data comparing ⁹⁰Sr in soils at nearby sites 2, 3, 4 as shown in Table II. The average difference between pairs expressed as a percent of the mean was calculated for each sampling year. The deviations range from 3 to 10%. We find these data very useful for convincing skeptics that soil sampling can be used to determine the cumulative fallout for a rather large area.

We now have some information on comparative sites in the New York area for ²³⁹Pu deposition. Table III shows the results of 6 samples taken in three different locations. The average ²³⁹Pu deposit is 2.3 mCi/km² with a standard deviation of 13%. If it were not so difficult to find suitable sites in the New York area we would probably have an even more precise value to report.

Analytical Precision

Something like a third of all soil samples analyzed by HASL or contractors are run as blind duplicates. The average percent deviations between aliquots of prepared samples submitted for analysis are shown in Table IV. Again we are expressing the deviation as the difference between pairs divided by the mean. For ⁹⁰Sr the errors are less than 10% except for the first year of sampling. The plutonium analyses were done in connection with the Rocky Flats study and the average percent deviation was 20. We began plutonium analyses in soil only last year and the procedure requires more skill at present than does the ⁹⁰Sr method. Under these considerations this comparatively larger error is understandable. We are presently analyzing fallout ²³⁹Pu in soil samples collected throughout the world and it appears that the analytical precision will probably average somewhere between 10 and 20%.

TABLE II

Location	Problems Sample Date	Distribution of ^{239}Pu per square kilometer																	
		1960		1961		1962		1963		1964		1965		1966		1967			
		Site 1	Site 2	Site 1	Site 2	Site 1	Site 2	Site 1	Site 2	Site 1	Site 2	Site 1	Site 2	Site 1	Site 2	Site 1	Site 2		
Alaska, Barrow	3	2	1	0	5	1	4												
North Dakota, Mandan	26	26	17	20	10					0	10	15	10	35	17				
Japan, Tokyo	5	7	12	25	32	26	26			40	32					61	31		
Illinois, Gales	40	12	11	21	22	21	22			50	50	70	75			94	80		
Arizona, C.S.	8	7	3	7	4	0	3			10	11			14	16				
Albuquerque	3	2	2	4	2	2	3			3	4								
Illinois, Gales	4	7	3	7	1	4	4									6	1		
Minnesota, Gull Lake	2	1	2	2	2	2	2	6	6								14 13		
Canada, Abisko	30					3	3			4	4					4	4		
Canada, Schem	5					10	20												
California, Los Angeles	2					0	4												
South Africa, Durban	2					0	4												
New Zealand, Collingwood	2					0	3			10	5					13	13		
NE Cap, Durban	10											10	5						
Avg. diff. bet. sites etc./yr		1		1		2		0		2		2		3		3			
Avg. error, %		0		1		3		0		4		3		10		4			

TABLE III

TOTAL ^{239}Pu IN SOIL AT NEW YORK AREA SITES

Sampling Period	Site	Depth (cm)	mCi per km ²
Dec. 1969	Fordham Univ.	0-20	2.0
Jan. 1970	" "	0-20	2.2
Jan. 1970	" "	0-20	2.6
July 1970	Bronx Botanical	0-28	2.5
Sept. 1970	Brookhaven	0-30	2.6
Sept. 1970	"	0-60	2.1
		Avg. 2.3 ± 13%	

TABLE IV

MEAN PERCENT DEVIATION BETWEEN DUPLICATE SOIL ALIQUOTS

Sampling Year	Isotope	Aliq. wt. (g)	No. of pairs	Deviation (%)
1956	^{90}Sr	500	52	11
1957	"	"	55	8
1958	"	"	102	6
1959	"	"	27	6
1960	"	250	50	9
1963	"	"	41	6
1965-1967	"	"	87	7
1970	"	100	12	5
1970	^{239}Pu	100	9	20

Sample Size

When we first started soil sampling about 15 years ago, we took 20, 3/8-in.-diam cores to 15 cm depth. As time passed and we had to go deeper to get all the ⁹⁰Sr, we cut down to 10 cores to minimize the physical exertion of carrying these large samples. The 10-core sample represents 622 cm² of surface area. To test the reliability of sampling 10 cores, Alexander collected duplicate samples at about 10 sites throughout the world. The average deviation turned out to be 8%² which convinced us that 10 core samples were adequate. At Rocky Flats we collected duplicate soils at 2 sites as shown in Table V. The rocky terrain made sampling difficult in some areas and under these non-ideal conditions we were satisfied with the agreement between duplicate samplings.

Analytical Accuracy

There is no such animal as a primary standard soil sample for artificial radioactivity. In the first place, no two soil samples are alike and in the second place, there is no way to add a radionuclide to a sample so that it represents the chemical and physical form of the element as it exists in the real world. There is such a thing as a secondary standard soil sample. This could be represented by a large quantity of soil which has been dried, blended, and pulverized and aliquots of which have been analyzed on an inter- and intra-laboratory basis. We have such a reference soil which we are now using for our plutonium fallout study. Table VI shows the available results. The average value of 0.042 dpm/g is based on 13 results from three laboratories using 100 and 1000 g aliquots. The average deviation is only 5% and we can see no significant difference among laboratories or aliquot size. This will become a more legitimate standard as time goes on and other laboratories report their data. One day it may even become a standard in the true sense of the word.

TABLE V
DUPLICATE SOIL SAMPLING IN THE
ROCKY FLATS AREA

Site	Sample	Depth (cm)	mCi per km ²	
			²³⁹ Pu	⁹⁰ Sr
6	1	0-20	2050	70
	2	0-20	1500	65
7	1	0-20	490	69
	2	0-20	440	64

TABLE VI
PLUTONIUM IN REFERENCE SOIL*

Lab	Aliquot (g)	dpm ²³⁹ Pu per g
HASL	1000	0.043
"	1000	0.042
"	1000	0.042
"	100	0.041
IPA	100	0.049
"	100	0.042
"	100	0.042
"	1000	0.044
"	100	0.041
"	100	0.041
"	100	0.042
"	1000	0.042
TLW	1000	0.041
"	1000	0.042
Avg. 0.042 ± 0.002 (5%)		

*Collected at Brookhaven in October 1970 and consists of 100, 3/8-in.-diam cores to 2 in.

The Blank

A real blank is a soil sample that is not contaminated with the radionuclide of interest. We inherited from Dr. Alexander a large quantity of soil collected in 1943. It has served as a blank through all of our ⁹⁰Sr programs and now for our plutonium work. The ²³⁹Pu results are given in Table VII. We conclude from these data that contamination by laboratory handling, reagents, and other possible sources under carefully controlled conditions, is not measurable.

The Radiochemical Procedure for Pu

Finally we would like to briefly discuss the radiochemical procedure. It was developed by Norton Chu at HASL to accommodate 100 g aliquots of the Rocky Flats soils. It involves leaching with 3 parts nitric acid and 1 part HCl.⁶ The plutonium is separated on an anion exchange column and finally electro-deposited on a platinum disc. The procedure works for 1000 g aliquots also, with some minor modifications. We have already demonstrated that the acid leach quantitatively removes Rocky Flats plutonium from soil.¹ Fallout plutonium can also be acid leached as we showed in the same report. We now

TABLE VII
PLUTONIUM IN BLANK SOIL

Lab	Aliq. wt. (g)	²³⁹ Pu dpm per g
HASL	100	0.0003 ± 100%
IPA	100	0.00008 ± 100%
	100	0.00008 ± 100%
	100	0.00005 ± 100%
	100	0.00003 ± 100%
	100	0.00003 ± 100%
	1000	0.00007 ± 100%
TLW	100	0.0002 ± 100%
	1000	0.00002 ± 100%

have additional supporting data which is included in the summary shown in Table VIII. An analysis of variance indicates that the pairs of data are the same at the 95% confidence level. We felt a year ago that the question of whether global fallout plutonium could be acid leached from soil was settled. This is simply a reiteration of our position with some additional evidence.

Fallout Pu-239

Dr. Harley has referred to our present study to inventory the global deposit of SNAP-9A ²³⁹Pu. One side benefit of this work will be a general picture as to how ²³⁹Pu is distributed. The figure shows the accumulated deposit of ²³⁹Pu at sites sampled in the United States

during the fall of 1970. There are no surprises or obvious anomalies. These are about the levels one would expect from the weapons tests conducted so far. The heavier precipitation areas and the mid-latitudes show the higher deposits just as we find with ⁹⁰Sr. We know there are local areas of contamination such as at Rocky Flats. On a country-wide scale, however, if there is any plutonium that has been or is being released from a nuclear facility, it has not perturbed the accumulated deposits from testing enough to detect it.

Conclusion

We have discussed soil sampling for the purpose of determining the accumulated deposit of initially air-borne radionuclides such as ⁹⁰Sr and plutonium. Site representivity, depth, sample size, and analytical precision and accuracy have been considered.

We are convinced on the basis of our quality control experience to date that the precision of replicate aliquoting and analysis is the determining factor in the overall error associated with soil sampling.

References

1. P. W. Krey and E. P. Hardy, "Plutonium in Soil Around the Rocky Flats Plant," HASL-235, August 1, 1970.
2. L. T. Alexander, et al., "Strontium-90 on the Earth's Surface," TID-6507, February 1961.
3. E. P. Hardy, et al., "Strontium-90 on the Earth's Surface II," TID-17090, November 1962.
4. M. W. Meyer, et al., "Strontium-90 on the Earth's Surface IV," TID-24341, May 1968.
5. J. H. Harley, editor, "Manual of Standard Procedures, D-4," NYO-4700.
6. N. Y. Chu, "Plutonium Determination in Soil by Leaching and Ion-Exchange Separation," Anal. Chem., 43, No. 3, pp. 449-452, March 1971.

TABLE VIII
ACID LEACH & COMPLETE DISSOLUTION OF ²³⁹Pu IN SOIL

Sampling year	Site	Depth (cm)	dpm ²³⁹ Pu per g	
			leach	comp. sol'n
1969	New York	5 - 20		
1958	Illinois	0 - 15	0.0044	0.0042
1967	New York	0 - 20	0.0051	0.0047
1970	Brookhaven	0 - 5	0.017	0.017
1970	Rocky Flats	0 - 20	0.042	0.042
1969	New York	0 - 5	0.060	0.080
1969	New York	0 - 2½	0.094	0.091
1970	Rocky Flats	0 - 20	0.21	0.24
1970	Rocky Flats	0 - 20	3.08	3.18
			17.5	16.0

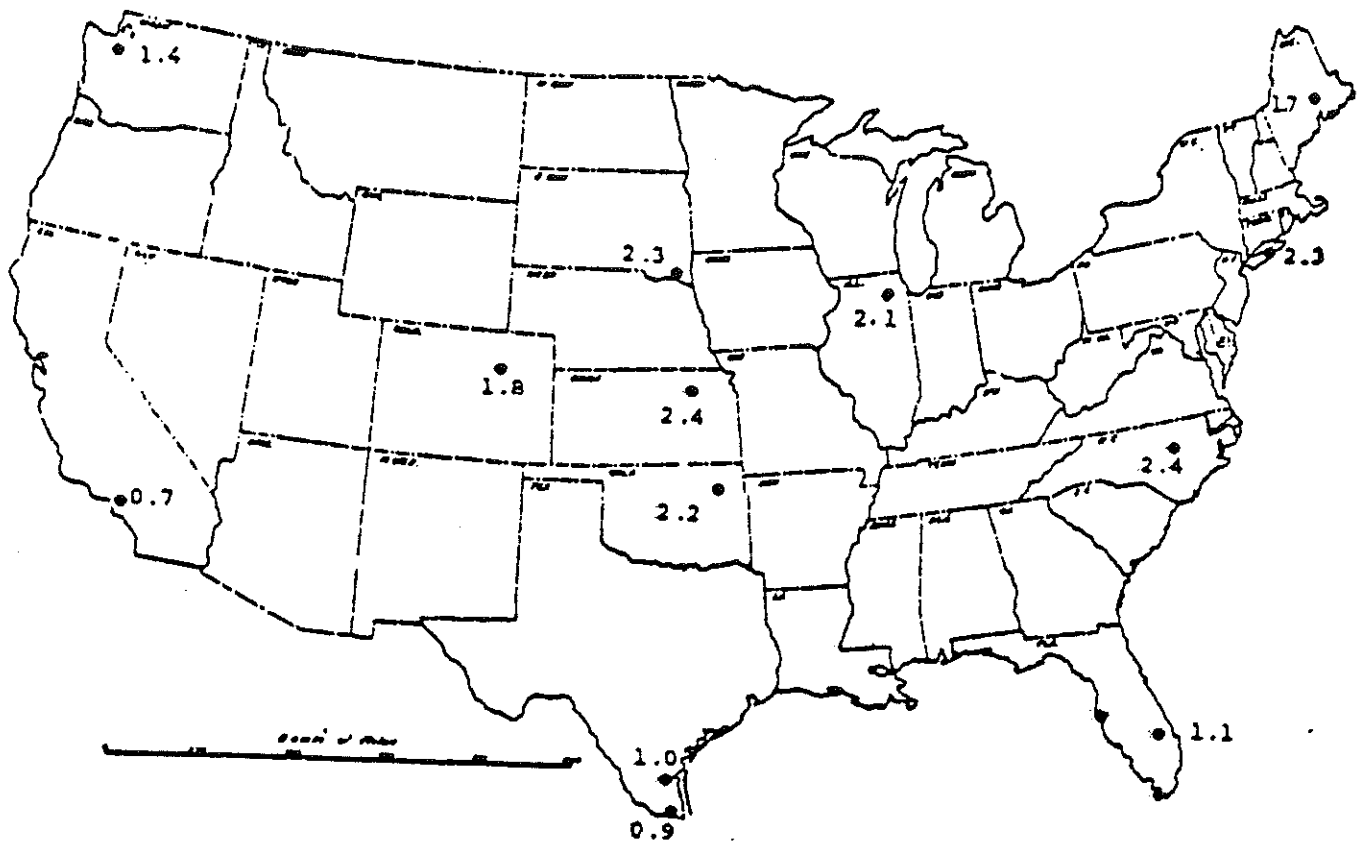

Fig. 1 -

Accumulated deposit of ^{239}Pu at sites sampled in the United States during 1970.

ANALYTICAL TECHNIQUES FOR THE DETERMINATION OF PLUTONIUM IN ENVIRONMENTAL SAMPLES

by

N. A. Talvitie
Western Environmental Research Laboratory
Environmental Protection Agency
Las Vegas, Nevada

ABSTRACT

Techniques used by the Western Environmental Research Laboratory for improving the accuracy and economy of plutonium determination in environmental samples are presented. Ignited soil, air filter, and vegetation samples are prepared for analysis by rapid, total dissolution methods in disposable polypropylene beakers. Plutonium in sea water is concentrated by coprecipitation on ferric hydroxide. High adsorption efficiency and separation from thorium are obtained by ion exchange separation of plutonium as the chlorocomplex ion. Hydrogen peroxide is used both for stabilization of plutonium in the quadrivalent state during adsorption and for reduction to the trivalent state during elution. Sample sources for alpha spectrometry are prepared by 60-minute electrodepositions from ammonium sulfate media on electro-polished stainless steel planchets mounted in low-cost, disposable cells. Counting data are converted by a computer program to a report format giving activity of ^{239}Pu and ^{240}Pu per sample unit, deposition per square kilometer, and error terms. The mean overall yield from environmental samples is 94%. The full width at half maximum resolution is 37.5 keV at 12.5 keV per channel and 21% counting efficiency. The minimum detectable activity is 10 fCi of ^{239}Pu for a 1000-minute count.

Introduction

The Technical Services Program of the Western Environmental Research Laboratory has analyzed environmental and biological samples for a number of plutonium studies. Among these were analyses of air, water, and soil samples at assistance to the State of Colorado in studies of the Rocky Flats area; of air and soil samples collected at Bikini Island; and of air, water, soil, precipitation, and vegetation samples collected in the offsite areas surrounding the Nevada Test Site. Although the analysis of sea water is primarily a readiness program for incidents involving plutonium-containing devices, the laboratory has provided analyses following one such incident.

The analytical process applied to samples consists of the following operations, which can be performed independently: sample control, preanalysis preparation,

dissolution and concentration operations, ion exchange separation, electrodeposition, alpha spectrometry, and computer computation of results. Aside from the considerations of accuracy and economy, the selection and development of techniques has been to provide a single process for all types of environmental and biological samples. Some of the techniques have been reported previously^{1,2} and are presented below as summaries. Techniques that differ from these are presented in detail.

Sample Control

The sample is assigned a serial number and all pertinent information is coded on an IBM card which accompanies the sample to the appropriate laboratory.

Preanalysis Preparation

At present, two types of environmental samples receive processing independent of the plutonium laboratory. Vegetation samples are ignited in large muffle furnaces and the pulverized ash is submitted for analysis. Soil samples are air-dried and sieved with a 10-mesh sieve. Any friable material and loose aggregates of soil in the oversize fraction are crushed in a mortar and passed through the sieve. Sticks and gravel retained by the sieve are discarded. A 30- to 40-ml aliquot of the 10-mesh fraction, obtained by repeated mixing and splitting in a riffle, is submitted for analysis in a four-ounce, wide-mouth jar. When soil and sediment samples have an unusually high organic content, it is more convenient to dry and ignite the sample before an aliquot is taken. Preanalysis preparations performed in the analytical laboratory are discussed in conjunction with sample dissolution and concentration techniques.

Dissolution and Concentration Operations

All samples are prepared for the ion exchange separation of plutonium by methods which, in effect, provide for total dissolution of the sample. The preparation is simplified by the use of the 6M azeotropic concentration of hydrochloric acid as the final solvent.

Soil. The aliquot of 10-mesh soil is dried in an oven overnight at 110°C and ground to a fine powder in a centrifugal ball mill. It is then returned to the sample jar and mixed by rotating the jar mechanically end-over-end.

A one-gram aliquot is ignited in a porcelain crucible, transferred to a 100-ml disposable polypropylene beaker, and spiked with ^{236}Pu . A mixture of hydrofluoric and nitric acids is added and evaporated to dryness on a steam bath with a specially-built top of 1/4-in. polyethylene. The top has 24 holes which allow the beakers to sit with two-thirds of their depth into the bath. The evaporation is repeated with a smaller volume of hydrofluoric and nitric acids to ensure complete decomposition of the soil and volatilization of fluosilicic acid. Nitrate and fluoride are removed from the residue by evaporating successive volumes of hydrochloric acid to dryness in the beaker. The residue is then dissolved in 6M hydrochloric acid containing a few drops of hydrogen peroxide. The peroxide reduces any hexavalent plutonium which might have been produced during the decomposition process.

Vegetation Ash and Air Filters. Vegetation ash and air filters are decomposed, spiked with ^{236}Pu and prepared as 6M hydrochloric acid solutions in the same manner as soil. One g of vegetation ash is weighed directly into a tared polypropylene beaker. Glass-fiber filters are folded into a wad, ignited in cupped stainless steel planchets, and transferred to the beaker. If the weight of the filter exceeds 1 g, a section is cut from the filter for analysis.

Composites are made by cutting circles from each filter to represent a known fraction of the filtering area. Filters composed of organic materials are ignited in platinum beginning with a cold furnace. Any amount of filter material can be handled provided that the total ash weight does not exceed 1 g.

Water and Precipitation. Sea water and saline water samples are acidified with hydrochloric acid. Plutonium-236, iron carrier, and hydrogen peroxide are added and the sample is heated to decompose the peroxide. The iron acts as a catalyst to decompose organic matter while the valence equilibrium in the presence of hydrogen peroxide serves to interchange the internal standard with the environmental plutonium. The plutonium is carried on a ferric hydroxide precipitate which is redissolved to give a 6M hydrochloric acid solution. Any insoluble residue is separated and then solubilized by an abbreviated version of the soil method.

Plutonium in fresh water and precipitation samples can also be concentrated by coprecipitation on ferric hydroxide. This is convenient if the sample has been filtered to determine the soluble plutonium separately from that associated with the suspended solids. For total plutonium in unfiltered samples, the sample is evaporated to dryness, wet-ashed with nitric acid and hydrogen peroxide, and that portion of the residue which is insoluble in 6M hydrochloric acid is solubilized by the abbreviated soil method.

Ion Exchange Separations

Apparatus. The ion exchange equipment consists of a bank of 24 columns in a hood specially-designed to carry off the acid fumes. The units are commercially available and consist of 14.5-mm-i.d. tubes having integral reservoirs and stopcocks with Teflon plugs. The catalog item is modified by adding a sealed-in, coarse glass frit. The columns contain a 20-ml volume of anionic resin capped with a layer of fine silica sand. The sand enables reagents to be added without particular care and, because the capillarity of the sand acts as valve to stop the flow, the operator is free to spend time on other phases of the analysis.

Column Operation. The 6M sample solution is adjusted to 9M by adding an equal volume of concentrated hydrochloric acid. Hydrogen peroxide is added to shift the equilibrium in favor of the quadrivalent state. The solution is filtered into the reservoir through a plug of glass wool in the stem of a disposable funnel. The filtration removes barium chloride which precipitates from glass fiber filter samples and sodium chloride which occasionally precipitates from evaporated water samples. After passage of the sample solution through the resin, co-adsorbed iron and uranium are selectively eluted with nitric acid. The nitric acid eluate can be reserved for the determination of ^{55}Fe and uranium.

The plutonium is eluted with a 1.2M hydrochloric acid-0.6% hydrogen peroxide reagent. The peroxide in dilute acid shifts the equilibrium in favor of the trivalent state and has another advantage in that no nonvolatile impurities are introduced. A 0.5-ml volume of concentrated sulfuric acid is added to the eluate, which is then evaporated overnight on a low-temperature hot plate. No fuming of the sulfuric acid or wet-ashing is required.

Electrodeposition

Apparatus. The disposable electrodeposition cells are constructed from linear-polyethylene liquid scintillation vials and hold a 3/4-in. stainless steel planchet. The cell supports and cathode contacts are 1/8-in. potentiometer shaft locks attached to machined Lucite bases with non-insulating banana-plug jacks. Twelve electrodeposition units are operated in parallel from a single power supply. A storage battery automatically supplies current in case of a power failure.

Electropolishing. The planchets are polished to a mirror finish while mounted in the cells using a reversed current of 1.2 A for six minutes. The electropolishing electrolyte is an adaptation of a formula containing phosphoric and sulfuric acids which is used industrially for polishing stainless steel.

Electrodeposition. The sulfuric acid solution of plutonium is diluted and neutralized to give a 1M ammonium-sulfate electrolyte having a pH of 2.0 to 2.3. The deposition is essentially quantitative in 60 minutes of electrolysis at 1.2 A.

Alpha Spectrometry

Apparatus. The counting system has eight silicon surface-barrier detectors. Two detectors are mounted in each of four vacuum chambers. The bias voltages for each pair of detectors are provided by dual power supplies. Each detector of the pairs has its own preamplifier, linear amplifier, and biased amplifier but the pairs of signals are brought into dual input 400-channel analyzers operating in the multiplex mode. The data from the four analyzers feed into a single digital printer through solenoid-operated banks of switches.

Spectrometry. The energy range is 3.5 to 6.0 MeV in 200 channels which covers most of the alpha emitters of interest. The plutonium peaks appear in the second 100 channels of the 200-channel spectrum. The resolution is three channels at 12.5 keV/ch or 37.5 keV full width at half maximum and the mean counting efficiency is 22%. The counts in 16 channels are summed for each of the plutonium isotopes.

Low-level samples are counted overnight for 1000 min and higher level samples during the day for 400

min. When the sample load is light, low-level samples are counted for 1400 min. The detection limit for ^{239}Pu with 1000- to 1400-min. counts is 10 fCi at two standard deviations. The detection limit of ^{238}Pu is 20 fCi because of the higher background.

Computer Computation

The sample data, sample and blank counts, and calibration data are coded for the computer. The computer is programmed to give a printed report of ^{239}Pu and ^{238}Pu activity per sample unit, deposition in soil per square kilometer, two sigma error terms, and the percentage yield of ^{238}Pu . The yield serves as a quality control over the sample preparation, ion exchange, and electrodeposition techniques. The yields are generally over 90% and average 94%.

Conclusions

Techniques have been selected to improve the accuracy and economy of the analytical process. Total dissolution methods insure that all of the plutonium is exchangeable. Low-cost, disposable equipment minimizes cross-contamination and eliminates the need for involved decontamination procedures. Electropolishing of the disposable stainless steel planchets results in a scrupulously clean and bright surface at low cost. The ion exchange and electrodeposition methods give high chemical yields and essentially weightless sample sources which contribute to counting precision.

The decomposition-dissolution procedure for soil, air filters, and vegetation ash requires less than two man-minutes of attention per sample and can be scaled up to handle 2.5 or 4 g of sample at little additional cost by using correspondingly larger disposable beakers. When samples larger than these are required in order to integrate a non-uniform distribution of plutonium, an aliquot can be taken for additional processing after the sample has been decomposed sufficiently to interchange the internal standard with the environmental plutonium. Sea water samples up to 10 liters in volume can be analyzed without modification of the basic procedures. Reference 1 contains a procedure for the analysis of 10-g samples of coral limestone soil. The sensitivity is adequate to detect background levels due to worldwide contamination from nuclear testing in 1 g of surface soil or in an air filter representing 500 cm³ of air. One-liter samples are adequate for the determination of plutonium in potable water.

Because the operations, other than sample preparation, are identical for all types of environmental and biological samples, technicians can conduct all phases of the analytical process after a short training period; and, because the operations can be conducted independently, peak sample loads can be handled by temporary assignment of personnel but do not require a corresponding increase in space and equipment.

References

1. N. A. Talvitie, "Radiochemical Determination of Plutonium in Environmental and Biological Samples by Ion Exchange." Presented at the American Industrial Hygiene Conference, Toronto, Ontario, Canada May 24-28, 1971. Submitted for publication in *Analytical Chemistry*.
2. N. A. Talvitie, "Electrodeposition of Actinides for Alpha Spectrometry." Presented at the 24th Annual Northwest Regional Meeting of the American Chemical Society, Salt Lake City, Utah June 12-13, 1969. Submitted for publication in *Analytical Chemistry*.

SAMPLING AND ANALYSIS OF SOILS FOR PLUTONIUM

by

F. E. Butler, R. Lieberman, A. B. Strong, and U. R. Moss
Eastern Environmental Radiation Laboratory
Environmental Protection Agency
Montgomery, Ala.

ABSTRACT

This paper describes the progress in analysis of soils artificially spiked with plutonium, soils containing particulate plutonium deposited from a processing plant, and soils containing fallout plutonium. The emphasis is on distribution of the actinide determined after both fusion and acid leaching techniques.

The residue from multiple evaporations of soil with hydrofluoric acid is fused with potassium fluoride and potassium pyrosulfate, dissolved in dilute sulfuric acid, and the solution evaporated to remove fluorides. Plutonium is then extracted with a hydrochloric acid solution with tri-isooctylamine (TIOA) and stripped from TIOA with dilute acid. Plutonium is coprecipitated with LaF_3 , the precipitate filtered onto a 0.2- μ polycarbonate filter membrane, and the plutonium counted in an alpha spectrometer.

Recovery, indicated by ^{236}Pu tracer added to each sample, is $75 \pm 6\%$ for 5-g soils. Recovery is higher for smaller samples. Assays of five interlaboratory cross-check soils in the range 0.5 to 16.0 pCi/g yielded an average error of only 3.6% by this method.

Introduction

There are a number of problems associated with the analysis of plutonium isotopes in soil samples. These problems can be attributed to one or both of the following conditions:

- The plutonium may be of a refractory nature and not easily separated from the soil matrix.
- The mode of distribution of the plutonium could have produced erratic and nonuniform dispersion of the radionuclide in the soil.

A number of fusion procedures have been developed to insure dissolution of refractory components, including plutonium, from soil samples. These methods, however, are limited to soil sample sizes of 10 g or less.

Analysis of small soil samples by fusion can result in misleading data dependent upon the degree of

nonuniformity of the plutonium at the sampling site. To overcome this difficulty, larger soil samples have been leached with various acid mixtures.

This paper describes a fusion procedure used at this Laboratory for plutonium analysis in soil samples. Results of the procedure are compared with various acid leach procedures performed on identical soil samples.

Experimental

Fusion of Soil. Initial experiments using the reagents potassium carbonate, sodium carbonate, sodium tetraborate decahydrate, barium sulfate, potassium hydroxide and others in various combinations were not successful in this Laboratory. The reagents showing the most promise were those used by Sill¹ for ^{210}Po analysis of soil. Variations of these reagents yielded a fused sample that was completely soluble in 6N HCl. The procedure is as follows:

1. Add 5 g of dried, sieved, and muffled (550°C) soil to a teflon beaker. Add ^{238}Pu tracer.

2. Add 35 ml of 28N HF and evaporate to dryness at low heat. Repeat three more times to volatilize the silica. Finally, add 15 ml of 12N HCl and evaporate.

3. Transfer the powdery residue to a 50-ml platinum crucible with the aid of a policeman.

4. Add 4 g of KF. Place a platinum top on the crucible and fuse over a meker burner for 30 min. Add 7.5 g of $\text{K}_2\text{S}_2\text{O}_7$ and fuse for an additional 30 min.

5. Cool the crucible in an ice bath, add 15 ml of 12N HCl and evaporate. Add 30 ml of water, heat and transfer to a beaker.

6. Rinse the crucible with a portion of 200 ml of 6N H_2SO_4 added to the beaker. Evaporate past the white SO_3 fumes to remove all traces of F^- .

Purification with TIOA. The liquid ion exchanger tri-isooctylamine (TIOA) reported previously² was used to separate the plutonium isotopes from calcium and other trace elements in soil as well as natural uranium. The procedure is as follows:

1. After removal of fluorides, dissolve the residue in 6N HCl with heat. Use the total volume of 400 ml 6N HCl, including rinse, to transfer the solution to a separatory funnel. Add 10 drops of 50% H_2O_2 to adjust the Pu to valence (IV).

2. Add 25 ml of 10% TIOA-xylene and shake briefly. Invert the funnel and release the pressure. Shake the solutions for one min.

3. Drain and discard the aqueous solution. Rinse the organic layer with 25 ml of 6N HCl and discard the rinse solution.

4. Strip the Pu from TIOA with two 25-ml volumes of 4N HCl-0.05N HF, shaking for two min each strip. (Uranium may then be stripped from the TIOA with 0.1N HCl and analyzed separately.)

5. Add 10 ml of 16N HNO_3 to the combined strip solutions and evaporate to dryness. Further wet ash the residue with 5 ml of 12N HCl plus 5 ml of HClO_4 .

Coprecipitation and Counting. Plutonium is coprecipitated with a trace amount of LaF_3 ³ and filtered onto either a polycarbonate filter membrane (Nuclepore) or a solvint membrane (Millipore). The automatic low-background alpha spectrometer was described previously.⁴ The procedure is as follows:

1. Dissolve the wet-ashed residue in 10 ml of 1N HCl, heating to about 60°C.

2. Cool the solution to room temperature and add 1 drop of 50% H_2O_2 to adjust Pu to valence (IV).

3. Add 0.1 mg of lanthanum (lanthanum nitrate dissolved in 1N HCl) and 2 ml of 3N HF and allow the precipitate to form for 30 min.

4. Filter in a Millipore apparatus onto a 25-mm 0.2 μ membrane. Wash the beaker with water then with alcohol.

5. Mount the filter membrane on double-faced adhesive tape attached to a 30-mm planchet.

6. Count the sample for 1000 min in the alpha spectrometer.

7. Calculate the quantity of plutonium isotopes and correct for the recovery of the known ^{238}Pu added initially.

Leaching Experiments. A soil sample was spiked with ^{238}Pu . The sample was dried, muffled, and thoroughly mixed and analyzed by the fusion procedure.

Duplicate leaching experiments were conducted with six solutions. One-g samples of soil were heated to boiling with 10-ml volumes of leach solution and then allowed to digest for one h. They were then filtered and the filters washed with hot water until the total volume for each sample was 20 ml. One-ml aliquots were analyzed by liquid scintillation counting. Results are shown in Table I. Note that the HCl leaches were more complete. Subsequent tests on a variety of soils, including those mentioned in the next section, showed that HF is often required for complete leaching.

TABLE I
LEACHING EXPERIMENTS OF SOIL CONTAINING
1700 DPM ^{239}Pu PER GRAM

Leach Solution	^{239}Pu dpm/gram	
	Sample 1	Sample 2
Water	0	0
4N HCl	1520	1600
12N HCl	1520	1600
1N HF	0	0
28N HF	80	220
4N HCl-1N HF	740	720

Results and Discussion

Figure 1 shows the alpha spectrogram obtained by analysis of a soil through the fusion procedure using the polycarbonate membrane. Note the good resolution of ^{236}Pu , ^{238}Pu , and ^{239}Pu , which allows the quantitative determination of the isotopes.

Table II shows good precision and accuracy of analysis of five interlaboratory soils by the fusion method. Although the fusion method and subsequent chemical separation is described for 5-g samples of soils, it has been employed for different quantities of soil. The fusion of more than 10 g of soil appears impractical with this procedure.

Analysis of 20 environmental soils from Montgomery, Alabama and Cape Kennedy, Florida, resulted in ^{236}Pu recovery of $75 \pm 6\%$. These 5-g samples assayed between less than sensitivity (.03 dpm) to 0.08 dpm/g ^{236}Pu .

One concern in analysis of soil is the distribution of plutonium particles and, therefore, the proper techniques for sampling and the optimum amount of sample required for representative analysis. To investigate these factors, a

soil was obtained from a nuclear processing plant where ^{239}Pu had been deposited in particulate form by accident approximately one year before receiving the soil. The particles had been covered with approximately 12 in. of fresh soil during the year prior to sampling.

The soil was dried, muffed at 550°C and thoroughly mixed prior to analysis of 21 1-g samples by the fusion method. The recovery of ^{236}Pu was $81.6 \pm 8.3\%$ with maximum and minimum recoveries of 99% and 64%. The ^{239}Pu in the soil was $0.57 \pm .40$ dpm/g; however, with maximum and minimum assays of 1.72 and 0.25 dpm/g. The relative standard deviation was $\pm 70\%$ compared to only 8% for the added tracer.

Twenty-g batches of the above soil were leached with a total volume of 200 ml of solution in the manner described in the Experimental Section. Ten-ml aliquots, representing 1 g of soil, were analyzed by the TIOA exchange procedure. Results are shown in Table III. Note that these analyses show the HCl-HF leaches yield ^{239}Pu assays very close to the mean of the 21 fusion assays.

Summary

1. A fusion method is described which yields accurate plutonium results for small samples (1 to 10 g) of soil.
2. The distribution of particulate plutonium deposited accidentally on soil can vary almost tenfold from gram to gram.
3. Analysis of a relatively large portion of the particulate soil after acid leaching results in less variation in replicate analysis than the analysis by fusion of 1-g aliquots.
4. No leach experiments were performed on actual atomic debris plutonium; therefore, no claim is made that the highly refractory plutonium in fallout is soluble in the various leach solutions.

Acknowledgment

The authors wish to express their appreciation for the technical assistance of Miss J. Favor, Mrs. E. W. Pepper, and Mrs. M. W. Williams in performing the laboratory experiments.

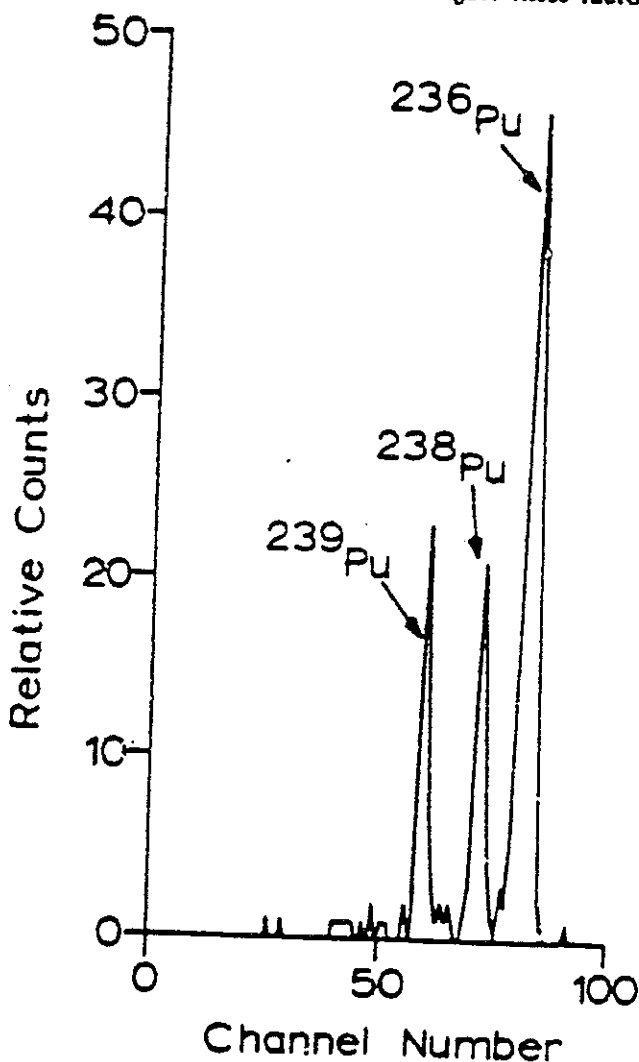

Fig. 1.

TABLE II
RESULTS OF PLUTONIUM IN SOIL CROSS CHECKS

Sample Number	EERL (pCi/g)		KNOWN (pCi/g)		ERROR, ²³⁸ Pu	(%) ²³⁹ Pu
	²³⁸ Pu	²³⁹ Pu	²³⁸ Pu	²³⁹ Pu		
1		.407		15.80		
		.319		15.90		
		.306		15.60		
	Avg.	.344		15.77	.26	15.68
2		—		.031		
				.032		
				.030		
	Avg.	—		.031	—	.031
3		—		2.43		
				2.56		
				2.31		
	Avg.	—		2.43	—	2.24
4		—		16.98		
				16.36		
				15.79		
	Avg.	—		16.34	—	15.59
5		—		0.51		
				0.51		
				0.45		
	Avg.	—		0.49	—	0.47
						4.2
						Avg. 3.6

TABLE III
LEACHING TESTS USING SOIL CONTAINING PARTICULATE ²³⁹Pu

Leach Solution	²³⁹ Pu Assay (dpm/g)	
	Sample 1	Sample 2
4N HCl	0.22	0.22
4N HCl - 1N HF	0.57	0.42
4N HCl - 2N HF	0.64	0.69

References

1. W. Sill and C. P. Willia, Anal. Chem. 37 No. 13 166 (1965).
2. F. E. Butler, Health Phys. 15, 19 (1968).
3. R. Lieberman and A. A. Moghissi, Health Phys. 15, 359 (1968).
4. H. L. Kelley, R. E. Shuping, R. H. Schneider, and A. A. Moghissi, Nuclear Instruments and Methods 70, 119 (1969).

EXPERIENCE GAINED FROM AN EXTENSIVE OPERATIONAL EVALUATION OF THE FIDLER

by

D. R. Case, W. T. Bartlett, and G. S. Kush
USAF Radiological Health Laboratory
Wright-Patterson AFB, Ohio

ABSTRACT

The prompt assessment of plutonium distribution resulting from nuclear weapons accident/incident debris depends strongly on the ability to deploy an operationally ready team of thoroughly trained personnel equipped with reliable equipment. A program of routine testing of four FIDLER response kits has resulted in a complete characterization of the instrument and a complement of personnel acquainted with its operation, shortcomings, and field application. Results of statistical reliability tests on the FIDLER, a discussion of instrumental deficiencies observed, and a summary of an accident/incident training program will be presented. The experience gained from such a program allows the USAF Radiological Health Laboratory to fulfill its responsibility for worldwide Air Force weapon accident/incident hazard evaluation.

Introduction

The ability to promptly evaluate the radiological hazards associated with nuclear weapons accidents and/or incidents is of prime interest to the Air Force. To satisfy this requirement, the USAF Radiological Health Laboratory has been tasked with providing an immediate response capability in the event of such an occurrence on a worldwide basis. We have prepared for this task by instituting a program for acquiring and maintaining appropriate instrumentation, and for training a complement of personnel in the use of this instrumentation in evaluating the distribution of accident/incident debris. This program has, as two prime objectives, the familiarization of personnel with the actual equipment and the maintenance of equipment in an operationally ready status. The basic equipment employed for the detection of plutonium and daughters is the Radiac Set P/N 400520, whose primary component is the FIDLER,¹ a scintillation instrument for detection of low-energy photons. The basic characteristics of this instrument have been outlined,¹⁻³ as well as investigations on the temperature dependence,⁴ and effects of overburden.⁵ These investigations have served well to supply the basic characteristics of the instrument. In

order to incorporate the FIDLER into a response ready program. Additional information was necessary to evaluate its serviceability and to identify and remedy and deficiencies in its long-term reliability. A program for routine calibration and evaluation of the stability of the FIDLER, coupled with field training sessions for response personnel, has been carried out for a period of 14 months. Evaluation of the statistical reliability of the instrument has aided in the identification and correction of several problem areas which could have hindered the validity of the FIDLER in a field situation. The result of such a program of testing and training is to insure that the instrumentation will be operational when needed, and to provide thorough familiarization with the equipment for those using it.

Methodology

The Radiac Set P/N 400520 (Eberline Instrument Co.) consists of three probes (a FIDLER scintillation probe, a PG-2 scintillation probe, and a SPA-3 scintillation probe), a PRM-5 pulse-rate meter, and various accessory components, housed in an aluminum, flex-hair-lined

carrying case. The PRM-5 is a battery operated rate meter with pulse-height analysis capability and supplies three switch-selectable, independently adjustable high-voltage settings. A total of four kits were employed in this study.

For routine use in Broken Arrow operations, the PRM-5 is set up to provide maximum response to plutonium and its daughters. Generally, the pulse-height analyzer is operated with a 100% window width. The three, switch-selectable high voltages are adjusted as described in Table I.

The long-term testing of the instrument reliability consists of performing measurements of the response of each instrument to the 17 keV and 60 keV photons of ²⁴¹Am. Since these response checks are incorporated into familiarization sessions, two procedures are followed. The first check consists of measuring the response of both the FIDLER and PG-2 probes to a nominal 100 nCi ²⁴¹Am source in contact with the detector face. Net counts per minute are tabulated and used to calculate running means and standard deviations. The second portion of the testing procedure consists of a calibration of the point and area sensitivity of each probe using procedures described by Tinney ¹ or is suspended at a height of 30.5 cm above a surface and the response of the 105 nCi ²⁴¹Am point source is measured according to the following equations:

$$Sp (\text{cpm}/\mu\text{Ci}) = \frac{\text{Net cpm}}{Q} \quad (1)$$

$$Sa (\text{cpm}/\mu\text{Ci} \cdot \text{m}^2) = \frac{2 \times 10^{-3} \pi}{Q} \sum (R)(N) \quad (2)$$

where

- Sp = point source sensitivity
- Sa = area source sensitivity
- Q = source strength in μCi
- R = radial distance of each response in cm
- N = response at radial distance R

These data are also tabulated and used to calculate a mean and standard deviation for each instrument. Data for each session are compared to the average and used to determine the need for corrective action.

TABLE I
HIGH VOLTAGE SETTINGS

Switch Position	Probe	Energy (keV)
HV1	FIDLER	17
HV2	FIDLER	60
HV3	PG-2	17

Results and Discussion

The data accumulated over a period extending from 22 April 1970 through 30 June 1971 have been summarized and are shown in Table II. Mean and standard deviation values are shown for point source sensitivity (Sp), area source sensitivity (Sa), and check source response. These results indicate that over a long-term period both the FIDLER and PG-2 are reproducible to within a 10 to 15% range. This correspondence is achieved with a minimum of preventive maintenance or attempts to continually optimize the settings of the instruments. In fact, a comparison of individual data with the averages has proven to be of value in detecting instrument deficiencies such as maladjusted high-voltage settings, incorrect window widths, and malfunctioning multiplier phototubes.

In addition to in-house maintenance of this equipment, we provide assistance to other Air Force and Government agencies on the operation of the Radiac Set. One particular problem has arisen in obtaining adequate response of the FIDLER probe to 17 keV photons. Adjustment of the high voltage to satisfactorily center the 17 keV peak has been encountered. Through a careful study of the correspondence of high voltage applied to center a given photopeak in the window, we have determined that the 17 keV peak position for the FIDLER and the maximum output of the PRM-5 are both approximately the same (1370 V). The difficulty has been corrected through modifications to the power supply to allow a maximum output of 1600 V. This increased voltage allows a more careful adjustment of the 17 keV peak in the analyzer window.

An exhaustive program for training of response personnel has also been instituted. This training consists of in-house efforts to provide realistic situations and periodic deployment of the equipment and personnel in aid of actual and/or anticipated radiological hazards. Our in-house training consists of sessions conducted by a staff of Health Physicists to acquaint personnel with the theory of operation, calibration and set-up, and field use problems of major significance to the successful utilization of the kit. Field exercises are also utilized to provide practical experience under simulated plutonium distributions. The effects of overburden, response time, etc., are demonstrated and coupled with instruction in proper survey techniques. In addition, personnel have been deployed with the Radiac Sets to aid in the evaluation of existing contamination areas. These teams have also aided in the health physics support of Apollo shots. These deployments are considered of great value in complementing in-house training and in providing continual reevaluation of equipment and techniques. It should be pointed out that the Radiac Set has been found to be a very easily deployable instrument.

TABLE II
RESPONSE DATA

Function	Unit 1		Unit 2		Unit 3		Unit 4	
	\bar{X}	σ	\bar{X}	σ	\bar{X}	σ	\bar{X}	σ
FIDLER HV-1 (Sa)	2906	212	2613	140	1786	170	2527	250
FIDLER HV-2 (Sa)	3328	442	3252	348	3195	188	2837	521
PG-2 HV-3 (Sa)	148	19	157	54	158	38	263	88
FIDLER HV-1 (Sp)	5053	61	7010	858	5082	36	5645	766
FIDLER HV-2 (Sp)	4937	141	7447	709	5009	105	5851	729
PG-2 HV-3 (Sp)	606	85	574	89	628	144	731	191
FIDLER Check HV-1	28.4K	6.0K	23.6K	5.3K	23.4K	4.2K	23.2K	5.0K
FIDLER Check HV-2	33.3K	8.2K	29.2K	6.7K	27.8K	5.5K	26.0K	5.9K
PG-2 Check HV-3	9.7K	0.9K	6.74K	2.5K	7.1K	2.5K	9.1K	4.0K

\bar{X} = mean value
 σ = one standard deviation

Summary

This program for periodic evaluation of the Radiac Set coupled with a program of training for personnel has allowed this laboratory to achieve an operationally ready status. The testing program has provided a basis for continually assuring that our equipment is operating in a reliable manner. In addition, necessary modifications to improve the reliability of the Radiac Set have been incorporated as a result of this testing. These experiences have allowed us to gain confidence in our ability to promptly respond to the need for radiological assessment of any situation involving fissionable materials.

References

1. C. T. Schmidt and J. J. Koch, "Plutonium Survey and X-Ray Detectors," in *Hazards Control Progress Report No. 26*, Lawrence Radiation Laboratory, Livermore, Rept. UCRL-50007-66-2 (1966), p. 1.
2. J. F. Tinney and J. J. Koch, "An X-Ray Survey Meter for Plutonium Contamination," in *Hazards Control Progress Report No. 29*, Lawrence Radiation Laboratory, Livermore, Rept. UCRL-50007-67-3 (1967) p. 6.
3. C. L. Lindekin and J. J. Koch, "Optimization Studies for the FIDLER Detector," in *Hazards Control Report No. 31*, Lawrence Radiation Laboratory, Livermore, Rept. UCRL-50007-68-2 (1968) p. 20.
4. T. O. Hoeger and J. F. Tinney, "Temperature Dependence of a Plutonium X-Ray Survey Instrument," in *Hazards Control Report No. 33*, Lawrence Radiation Laboratory, Livermore, Rept. UCRL-50007-69-1 (1969) p. 14.
5. J. F. Tinney and T. O. Hoeger, "Overburden Attenuation Measurements for ^{239}Pu - ^{241}Am Using the FIDLER Detector," in *Hazards Control Report No. 33*, Lawrence Radiation Laboratory, Livermore, Rept. UCRL-50007-69-1 (1969) p. 6.
6. J. F. Tinney, "Calibration of an X-Ray Sensitive Plutonium Detector," in *Hazards Control Report No. 31*, Lawrence Radiation Laboratory, Livermore, Rept. UCRL-50007-68-2 (1968) p. 24.

USE OF PLUTONIUM-236 TRACER AND PROPAGATION OF ERROR

by

Claude W. Sill
Health Services Laboratory
U. S. Atomic Energy Commission
Idaho Falls, Idaho

ABSTRACT

The use of ^{236}Pu tracer to make yield corrections in the determination of both ^{238}Pu and ^{239}Pu is discussed, both from the theoretical and practical points of view.

The consequence of using too-small quantities of ^{236}Pu tracer is that the uncertainty in the yield determination becomes much greater than the uncertainty in the total count of plutonium in the sample. If large quantities of ^{236}Pu tracer are used to improve the statistics of the yield determination, other problems are introduced; these are discussed.

Plutonium-236 tracer has been used almost universally for several years to make yield corrections in the determination of both ^{238}Pu and ^{239}Pu . Although it is of great assistance when used properly, many investigators have apparently considered the ability to correct for chemical inadequacies to be an adequate substitute for good chemistry, even when the yield goes as low as 10%. There are several problems associated with its use, none of which have even been mentioned in any of the articles on the determination of plutonium so far examined.

As should be well known, the statistical uncertainty in the determination of the yield must be passed on to the determination of the nuclide being sought in the sample. Yet, few analysts seem to consider, at least in their published works, the effect of quantity of tracer used on the sensitivity and accuracy of the determination. A widely used method of error propagation¹ shows that the fractional error in the value of the nuclide being sought is equal to the square root of the sum of the squares of the fractional errors in each of the independent variables involved. If X, Y, and Z are the total counts obtained in the energy intervals for the ^{239}Pu being sought, the ^{236}Pu recovered through the procedure, and the ^{236}Pu in the standard from the same quantity of tracer, respectively; g, E_z , and t are grams of sample, counting efficiency used in the standardization, and time in minutes, respectively; and B_x , B_y and B_z are the respective background counts

or other corrections for the same counting time, then

$$^{239}\text{Pu dpm/g} = \frac{(X - B_x)}{(Y - B_y)} \cdot \frac{(Z - B_z)}{g E_z t}$$

In other words, the concentration of ^{239}Pu in the sample is simply the ratio of net counts of ^{239}Pu to ^{236}Pu recovered multiplied by the dpm/g of ^{236}Pu added as tracer. It should be noted specifically that once the concentration of ^{236}Pu used has been determined, neither counting time, counting efficiency, nor errors therein have any effect on the accuracy of the determination except as they affect the statistical errors resulting from total number of counts obtained. Elimination of the effect of changes in counting efficiency is particularly important in routine work because a significant source of inaccuracy is the variation in counting efficiency that frequently results from uneven distribution of activity in the electro-deposited plate and variations in both distance and vertical alignment of the counting plate with respect to the detector. If it is arranged so that g, E_z and t do not contribute significantly to the error, the absolute uncertainty in the ^{239}Pu concentration in dpm/g equals

$$^{239}\text{Pu dpm/g} \cdot \frac{S_x}{X} + \frac{S_y}{Y} + \frac{S_z}{Z}$$

where S_x indicates the uncertainty in X and is taken equal to $(X + B_x)^{1/2}$. When the blanks or other corrections are negligible compared to the total integral, S_x becomes equal to $X^{1/2}$, and the fractional error function reduces to

$$\frac{1}{X} + \frac{1}{Y} + \frac{1}{Z}$$

or the square root of the sum of the reciprocals of each of the total counts involved, which is simpler to use. If the quantity of ^{239}Pu and/or the counting time used in the standardization is sufficiently large, the error function simplifies to the first two terms in either equation. If the quantity of ^{239}Pu tracer used in the sample and the yield are both sufficiently high, the total uncertainty in the determination will be determined entirely by the uncertainty in the ^{239}Pu count, as it should be.

With the small quantity of ^{239}Pu tracer used by many workers, the uncertainty in the yield determination becomes much greater than the uncertainty in the total count of the ^{239}Pu from the sample. For example, if a 100-g sample containing 0.1 dpm/g were traced with 3 dpm of ^{239}Pu with a yield of 50% and the final plutonium fraction were counted for 10^3 min at 25% counting efficiency on a clean detector, and the same quantity of tracer were standardized under the same conditions but with a yield of 100%, the overall fractional error would be

$$\frac{1}{1250} + \frac{1}{375} + \frac{1}{750}$$

or 0.069. The resulting uncertainty of 13.8% at the 95% confidence level is probably acceptable in the determination of the low levels presently resulting from global fallout. However, it is undesirably large for more precise needs at higher levels and is unnecessary in any case. At the 95% confidence level, the uncertainty in the yield determination alone is 12.6% compared to only 5.6% due to the uncertainty in the ^{239}Pu count alone. The uncertainty in the ^{239}Pu count alone could be further reduced to 4% if the yield were also increased to 100%. As the concentration of ^{239}Pu in the sample becomes higher, the same imprecision becomes less acceptable but the overall uncertainty in the final answer is still determined by the relatively larger uncertainty in the yield determination resulting from use of too little tracer. In fact, it should not be difficult to develop a procedure whose recovery would be known more precisely than 12.6% without a separate yield determination. In our experience, the present procedure is reproducible to within 5%.

On the other hand, if large quantities of ^{239}Pu are used to improve the statistics of the yield determination, other problems are introduced that are even more serious when the ^{239}Pu content is low. Plutonium-236 has two main alpha rays at 5.769 and 5.722 MeV both of which are higher in energy than those of either ^{239}Pu or ^{240}Pu . Although the three isotopes can be resolved easily and completely with current instrumentation, some of the alpha particles from the higher-energy ^{236}Pu are scattered continuously and quite uniformly through all lower

energies to zero. The quantity scattered is dependent not only on the particular counting chamber used and the quantity of absorber present but also on the condition of the detector itself. The percentage scattered is relatively small but if the total number of counts collected in the main peak becomes very large, the number scattered into the lower channels represents a significant increase over the normal background of a clean detector. The consequent decrease in both sensitivity and precision for ^{239}Pu soon becomes the overriding consideration and makes the imprecision in the yield determination of secondary importance. Furthermore, ^{236}Pu decays to ^{232}U which decays in turn to ^{228}Th both of which lie between ^{239}Pu and ^{240}Pu , further complicating the resolution and increasing the scatter. Even if freshly purified, the ^{236}Pu will regrow its 72-yr daughter to about 0.5% of the ^{236}Pu activity in 6 months, necessitating repeated purification. However, the greatest drawback is that ^{236}Pu generally contains both ^{239}Pu and ^{240}Pu in quantities that are easily detectable when large quantities of ^{236}Pu and/or long counting times are used. As with the scattered radiation, the resultant increase in background soon becomes intolerable in a procedure for the determination of low levels of ^{239}Pu and ^{240}Pu in the environment.

The ^{236}Pu presently in use in this laboratory, after purification from ^{232}U and its daughters, gives 0.004% of the total ^{236}Pu integral per channel (12.5 keV) at lower energies due to scatter only. The scatter plus plutonium contamination is 0.07% of the total ^{236}Pu integral in the ^{239}Pu integral (10 channels), and 0.7% in the ^{240}Pu integral (16 channels). If a combination of ^{236}Pu activity, counting time, and counting efficiency are chosen so that 10^3 , 10^4 or 10^5 total counts are obtained on both standard and sample, the statistical uncertainty at the 95% confidence level on the yield determination alone will be 9, 2.8, and 0.9%, respectively. If we define the detection limit as being the net count that is equal to twice its own standard deviation and take 3 pulses in the particular integral as a normal detection limit on a clean detector, the increased background from these same three levels of total ^{236}Pu counts would raise the detection limit by about 1.7, 2.7, and 7 times, respectively, for a 10-channel integral due to scattering only; by about 2, 3.3, and 9 times, respectively, for the ^{239}Pu integral; and by about 3.3, 9, and 26 times, respectively, for the ^{240}Pu integral.

The increased background has a similar effect in decreasing the precision of the determination and the uncertainty increases either as the sample activity decreases or as the quantity of ^{236}Pu used increases. Consequently, a compromise is necessary, and the quantity of tracer used should be much less for low-level samples than for high-level ones. Because the concentration of the ^{236}Pu tracer is the fundamental value on which all subsequent analyses depend, its determination should be carried out as carefully and accurately as possible, using as least as many total counts as will be obtained subsequently from the highest sample to be analyzed. The standardization is completely separate from any actual sample analyses so

that large numbers of counts can be used without problems due to scatter or contamination with other plutonium nuclides. In fact, a large count will be helpful in determining the scatter and contamination with adequate precision. Consequently, the uncertainty in the determination will depend entirely on the number of counts of ^{239}Pu and ^{236}Pu obtained in the analysis. If the yield is also high, even the ^{236}Pu count will not contribute significantly to the imprecision until the ^{239}Pu count becomes nearly equal. For example, in this laboratory, a total of 10^4 to 10^5 counts are used for standardization of the ^{236}Pu tracer and determination of the scatter; 2×10^3 counts are used on background-level samples up to about 0.8 dpm/g using a 10^3 -min count at 25% counting efficiency on a 10-g sample; 10^4 counts are used for medium-level work up to about 4 dpm/g; and 10^5 counts

are used for highest precision on higher levels at which the increased scatter and contamination will be relatively insignificant. The upper end of the two lower ranges is the level at which the uncertainty in the ^{239}Pu count becomes equal to that in the yield determination, i.e., the total counts of ^{239}Pu and ^{236}Pu recovered are equal.

Reference

1. R. J. Overman and H. M. Clark, "Radioisotope Techniques," McGraw Hill, New York, N. Y., 1960, p. 109.

this point, the bulk of the soil components have been removed since monovalent and divalent species, such as sodium and calcium, and most trivalent species will not have been extracted into HDEHP under these conditions. Further, most of the higher oxidation state species (e.g., zirconium), which have been extracted will not be back-extracted. Large amounts of iron, which interfere with the subsequent plutonium analysis, can be eliminated by performing the initial extraction from 6M HCl and by washing with 6M HCl as required.

The final solution containing the back-extracted plutonium can not be concentrated and analyzed by any standard method.² Since the initial soil dissolution is quantitative and yields of 90% can be achieved through the extraction, the sensitivity of the method is limited only by the amounts of soil dissolved, the volumes of solution one wishes to handle at one time, and the α -counting system to be used. The procedure has been applied to samples containing as little as a disintegration per minute of plutonium activity.

Experimental Procedure

Dissolution of Soil Samples. An ≈ 50 g sample of the pulverized soil is placed in a Teflon beaker and 50 ml of fuming HNO_3 is added. The mixture is slurried by stirring with a stainless steel stirring rod until all of the dry powder is thoroughly wet. 100 ml of concentrated HClO_4 is added to the slurry, and this is followed by the gradual addition of 100 ml of concentrated HF. The addition of HF is accompanied by the release of voluminous quantities of gas. The mixture must be cooled in a water bath and the HF added in small portions to prevent the solution from overflowing the beaker. The effervescence subsides appreciably after $\approx 75\%$ of the HF has been added.

After addition of the HF, the Teflon beaker is heated on a hot plate (medium setting), to heavy fumes of HClO_4 . The beaker is cooled in a water bath, and 50 ml of HF is added. (If the beaker is not sufficiently cooled, the HF will spatter rather violently when it is added.) This HF fuming step is performed three more times, adding HClO_4 if necessary to prevent the mixture from becoming completely dry. During the fourth fuming the contents of the beaker are taken almost to dryness. The beaker is cooled and 100 ml of 4M HCl is added. The mixture is boiled. The contents of the beaker are transferred to 40-ml short-taper Vycor centrifuge tubes and centrifuged. The supernate is poured into a second Teflon beaker and 50 ml of concentrated HF and 50 ml of concentrated HClO_4 are added. The beaker is then heated on a hot plate (medium setting). The original beaker is rinsed with hot 4M HCl, and the wash is transferred to the centrifuge tubes containing residue. The contents of the tubes are stirred and centrifuged, and the supernates are added to the second beaker. Each tube containing residue is boiled over a burner with ≈ 2 ml of 6M NaOH. Sufficient

4M HCl is added to acidify the mixture. The solution is again boiled and centrifuged while still hot. The supernate in each case is added to the second Teflon beaker. The treatment with NaOH and HCl is repeated, and the supernates are again added to the second beaker. The residues in the tube are transferred to the original beaker with HCl and treated with four HF- HClO_4 fumings.

The contents of the second beaker are heated to heavy fumes of HClO_4 and cooled. Fifty ml of HF is added to the solution which is then fumed almost to dryness and again cooled. Then ≈ 100 ml of 6M HCl is added. The mixture is warmed, transferred to Vycor centrifuge tubes and centrifuged. The supernates are poured into a polyethylene bottle. Any remaining residue is repeatedly boiled with 6M HCl, centrifuged and the supernate is added to the polyethylene bottle. The HCl dissolution treatment is continued until no visible reduction in the amount of residue is observed.

The contents of the original beaker are fumed almost to dryness, and ≈ 100 ml of 4M HCl is added. The mixture is boiled and transferred to the centrifuge tubes containing the insoluble residue from the second beaker. The contents of the tubes are stirred and centrifuged. Again, the supernates are poured into the second beaker and fumed twice with HF- HClO_4 . Any precipitate in the tubes is treated with NaOH-HCl as described previously and the mixture centrifuged. The supernates are added to the second beaker. Then, if any residue remains in the centrifuge tubes, HF- HClO_4 fumings are repeated until NaOH-HCl treatment gives complete solution. The resulting solutions are added to the second beaker. The solution in the second beaker is treated with 50 ml each of concentrated HF and HClO_4 , taken to heavy fumes of HClO_4 , and cooled. Then 50 ml of concentrated HF is added and the solution is fumed almost to dryness. The residue is dissolved in 6M HCl and the solution is added to the polyethylene bottle.

The final solution tends to salt out on standing for several days. However, heating of the solution just to boiling causes the precipitated salts to redissolve.

Plutonium Extraction. A suitable plutonium tracer, usually ^{236}Pu , is added to the sample solution for yield determination. Sufficient 10M NaNO_2 is added to make the solution 0.2M in this reagent. The resulting solution is heated just to boiling and cooled to room temperature. A volume of 1M HDEHP in *n*-heptane equivalent to one-third that of the sample is pre-equilibrated with 6M HCl and added to the sample in a separatory funnel. The mixture is shaken for 1 min, and the organic (upper) and aqueous phases are allowed to separate. The aqueous phase is discarded. The organic layer is washed five times with equal volumes of 6M HCl and the washes discarded. The HDEHP solution is shaken for ≈ 10 sec with one-third its volume of 0.2M DBHQ in 2-ethyl-1-hexanol. The plutonium in the resulting mixture is back-extracted by shaking for 2 min with one-half volume of 6M HCl. The phases are allowed to separate for 5 min and the organic

SEPARATION AND ANALYSIS OF PLUTONIUM IN SOIL

by

G. E. Bentley, W. R. Daniels, G. W. Knobeloch,
F. O. Lawrence, and D. C. Hoffman
Los Alamos Scientific Laboratory
University of California
Los Alamos, New Mexico

ABSTRACT

A procedure for the analysis of plutonium in large samples of soil has been developed which gives plutonium yields of at least 90%. The soil samples are completely dissolved by repeated fumings with HNO_3 , HF and HClO_4 , followed by treatment with NaOH to give silicate-free solutions in either HCl or HNO_3 . As much as 50 g of soil, with final concentrations corresponding to ≈ 100 mg/ml of solution, have been dissolved. (Processing of larger amounts of material appears to be limited only by the volume of solution that can be handled.) The sample may be traced by adding an appropriate plutonium isotope. NaNO_2 is added to insure that all of the plutonium is in the (IV)-oxidation state, thus providing for exchange between the plutonium tracer and the plutonium in the sample. The solution is extracted into di-2-ethylhexyl orthophosphoric acid (HDEHP); the HDEHP is then washed several times with 6M HCl to remove iron. After the washing, 2,5-ditertiarybutylhydroquinone (DBHQ) is added to reduce the Pu(IV) to Pu(III), which is then back-extracted into 6M HCl . The plutonium may then be determined by any standard method.

Introduction

In connection with the responsibility of the LASL Radiochemistry Group for the analysis of the underground debris resulting from the testing of nuclear devices at the Nevada Test Site, procedures for the quantitative analysis of plutonium in soil utilizing extraction into di-2-ethylhexyl orthophosphoric acid (HDEHP) have been developed. Procedures involving coprecipitation with LaF_3 are not suitable when large volumes of solutions of high ionic strength are to be analyzed. The present work describes the adaptation of our standard procedures for the dissolution of dirt and the extraction of plutonium to the separation of low-level plutonium from surface soils.

Experimental Method

When plutonium is to be determined in soils containing no detectable activity with which to follow the

yield of various steps in the dissolution procedure, quantitative recovery of plutonium is insured by completely dissolving the soil sample by fuming with HF , HNO_3 and HClO_4 , followed by treatment with NaOH and then HCl . The plutonium, in either the (IV)- or (VI)-oxidation state, can then be extracted into HDEHP in *n*-heptane from HNO_3 or HCl solutions of a wide range of concentrations. We have found 6M HCl solutions to be convenient since the extraction coefficients for iron and many other contaminants show minima at this molarity. However, since the extraction coefficient for Pu(IV) in 6M HCl is about an order of magnitude higher¹ than for Pu(VI), NaNO_2 is added to insure that the plutonium is in the (IV) state. (This also provides for exchange if plutonium tracer has been added.)

The plutonium is recovered¹ from the extractant by addition of 2,5-ditertiarybutylhydroquinone (DBHQ) which reduces the plutonium to the (III) state and strongly complexes it. The Pu(III) may then be readily removed from the organic phase by extraction with dilute HCl . At

layer is discarded. The aqueous solution is reduced in volume to 5 ml or less by boiling and water is added to make the solution 3M in HCl, with the final volume being no more than 10 ml.

The final plutonium separation and determination are carried out by a standard LaF_3 coprecipitation followed by an anion exchange resin column technique² involving elution of the plutonium from the resin by reduction of Pu(IV) to the (III) state with an HI-HCl mixture.

Discussion

Samples of surface soil were collected from five locations at the Nevada Test Site. The samples were taken from areas which were believed to contain little or no plutonium. About 500 g of dirt (avoiding rocks > 2 cm in diam) was obtained from the surface at each sampling point. No activity could be detected in any of the samples with an alpha-survey meter.

Two \approx 50 g portions of each dirt sample were dissolved, giving final concentrations corresponding to \approx 100 mg of soil per ml of solution. The plutonium was extracted by the described HDEHP procedure. No difficulties were encountered, and, in fact, the high dirt concentration seems to aid the phase separation during the initial extraction. A 50-ml aliquot of solution from each sample was analyzed without adding plutonium tracer so that any isotopes of plutonium present in the sample could be determined, and the appropriate choice of tracer made.

Because of the time (\approx 20 h) that is required to dissolve the samples using this procedure, it would not be practical to use it to determine plutonium in a large number of samples. The procedure would, however, be useful to check a faster leach-type of procedure for completeness of plutonium recovery. This is especially true if samples with very low amounts of plutonium were being determined.

Our procedure could be shortened considerably if the small amount of sand-like residue remaining after one complete cycle could be discarded. In the application of this procedure to debris from nuclear devices, the large amount of gamma activity provides a measurement of the completeness of dissolution; inactive residues may be discarded. Possible future work might involve the use of tracers to determine the advisability of discarding such residues.

References

1. ORNL Chemical Technology Division, Annual Progress Report ORNL-4272, May, 1968.
2. J. Kleinberg (ed.), Collected Radiochemical Procedures, Los Alamos Scientific Laboratory Report LA-1721, 3rd Ed. (1967), p. 91.

COMPARISON OF A LEACHING METHOD AND A FUSION METHOD FOR THE DETERMINATION OF PLUTONIUM-238 IN SOIL

by

C. T. Bishop, W. E. Sheehan, R. K. Gillette, and B. Robinson
Monsanto Research Corporation
Mound Laboratory
Miamisturg, Ohio

ABSTRACT

Both a leaching and a fusion procedure, followed by alpha pulse-height analysis, were used to determine the plutonium content of four soil samples. Thirty-one plutonium determinations were made following an acid leach procedure. Twenty-one plutonium determinations of these same four soil samples were made following the potassium fluoride-pyrosulfate fusion method developed by C.W. Sill and K. W. Puphal. Plutonium concentrations in the four soil samples analyzed were found to be 0.04, 0.19, 1.6, and 20 dis/min of ^{238}Pu /g of soil. Leaching and fusion results were essentially in agreement. As a further check, eight leached residues from one of the four soil samples were dissolved by the fusion method and analyzed; results indicated that greater than 90% of the ^{238}Pu was removed from the soil by acid leaching.

Comparison of the precision of the fusion procedure with the precision of the results of the four soil samples analyzed by the fusion method indicates a nonuniform distribution of plutonium in the soil. This is probably due to the particulate nature of the plutonium contaminants in the soil.

Introduction

Early in 1970, Mound Laboratory initiated a program to develop an improved, relatively simple and reliable analytical procedure for the routine determination of plutonium in soil. Prior to July 1970, all soil sample analyses had been performed by the Environmental Control Analytical Group using an acid-leach method of dissolving the plutonium from the soil. By July 1970, a serious debate was well under way in the scientific community concerning the effectiveness of the leach method as compared to a total dissolution of the soil accomplished by conventional fusion methods.

To evaluate these two methods of plutonium dissolution from soil and achieve our own assurance that methods being used at Mound Laboratory for routine plutonium soil analyses were reliable, the Analytical Section of the Nuclear Operations Department performed analyses on a select number of soil samples by a fusion

procedure. The four soil samples used in this study covered a wide range of ^{238}Pu concentration, i.e., from 0.04 dis/min/g to 20 dis/min/g of ^{238}Pu . It is significant that these four soil samples were analyzed by two essentially independent analytical laboratories. The personnel, counting systems, and standards employed in the fusion determination were all different from those employed in the leaching method. The purpose of this report is to present the results of the analyses of these four samples, and to show the indicated agreement between leaching and fusion methods in the determination of ^{238}Pu in soil.

The composite soil sample¹ is dried in stainless steel pans on a hot plate. The core samples are placed in the pans in such a manner that the vegetation on the surface of the individual cores can be charred by a propane torch. After the vegetation is charred and the soil aggregates are broken up, the sample is mixed well for complete drying. The samples are ground with a mortar and pestle. The larger rocks, those not passing through a 20-mesh screen,

are removed from the sample. The remaining sample is ground and screened through a 35-mesh screen, placed into a one-gal plastic container, and weighed. Fifty-g aliquots are weighed and analyzed by one of the two acid leach methods. Ten-g aliquots are used in the fusion analyses.

Acid Leach Method

The flow diagram in Figure 1 summarizes the two acid leach procedures that have been used at Mound Laboratory. On the left side is the original procedure by which the leach results reported here were obtained. The procedure currently in use (referred to as the current method) is shown on the right side of Figure 1.

In the original method, the ^{238}Pu tracer is added to the soil and the sample is placed in a muffle furnace at 500°C for 30 min to convert the ^{238}Pu tracer to an oxide. This sample is then leached by vigorous shaking for approximately 1 h with 100 ml of concentrated nitric acid and 1 ml of concentrated hydrofluoric acid at room temperature. After standing overnight, the solution is separated from the soil and adjusted to 4N in nitric acid. The plutonium is extracted into a 10% triisooctylamine (TIOA)-xylene solution according to the method reported by F. E. Butler.² The plutonium is back-extracted from

the TIOA-xylene solution with dilute nitric acid containing sulfur dioxide. This solution is adjusted to 10N in hydrochloric acid, passed through a chloride anion exchange column, and eluted with 6N hydrochloric acid containing 0.024% hydrogen iodide according to the method reported by L. C. Henley.³ The eluted solution is taken to dryness in nitric acid, and an ammonium sulfate electrolytic plating bath is prepared according to the method reported by I. A. Dupzyk.⁴

The current leach procedure closely follows the method reported by N. Y. Chu.⁵ In this method 100 ml of a 3-to-1, by volume, mixture of concentrated nitric to concentrated hydrochloric acid is used to leach the plutonium from the soil. Here the mixture is heated while stirring for 1 h at near boiling temperature. The leach solution is removed and a second leach is carried out in the same way. Both leach solutions and a water rinse of the soil residue are combined for further analysis. This solution is evaporated to near dryness to remove the hydrochloric acid and adjusted to 7.5N in nitric acid. Sodium nitrite is then added to the solution to ensure a +4 oxidation state for the plutonium before it is passed through a nitrate anion exchange column.⁵ The column is rinsed with concentrated hydrochloric acid as the first measure to separate the natural thorium from the sample. The plutonium is then eluted with 6N hydrochloric acid, containing 0.024% hydrogen iodide. The eluted solution from the nitrate column is adjusted to 10N in hydrochloric acid, passed through a chloride anion exchange column as a final decontamination step for natural thorium, and finally eluted and electroplated as in the original method. The complete decontamination of natural ^{228}Th is essential for a ^{238}Pu determination due to the closeness of the minor ^{238}Pu alpha energy (5.46 MeV) and the maximum ^{228}Th alpha energy (5.42 MeV).

In summary, the changes in the leach procedure were replacement of the nitric acid leach with the method reported by Chu, and substitution of the nitrate anion exchange column for the TIOA liquid extraction step. The improvement gained by the current leach procedure is that metals such as iron and lead that interfere with electrodeposition are more completely separated by the nitrate anion exchange column. This results in better recoveries of plutonium, and reduces slide deposits during electrodeposition to produce a much better alpha source for more effective pulse height analysis. Tracer recoveries using the original procedure were quite low and erratic, $46 \pm 27\%$, while the recoveries using the modified procedure have been generally much higher, namely $82 \pm 19\%$.

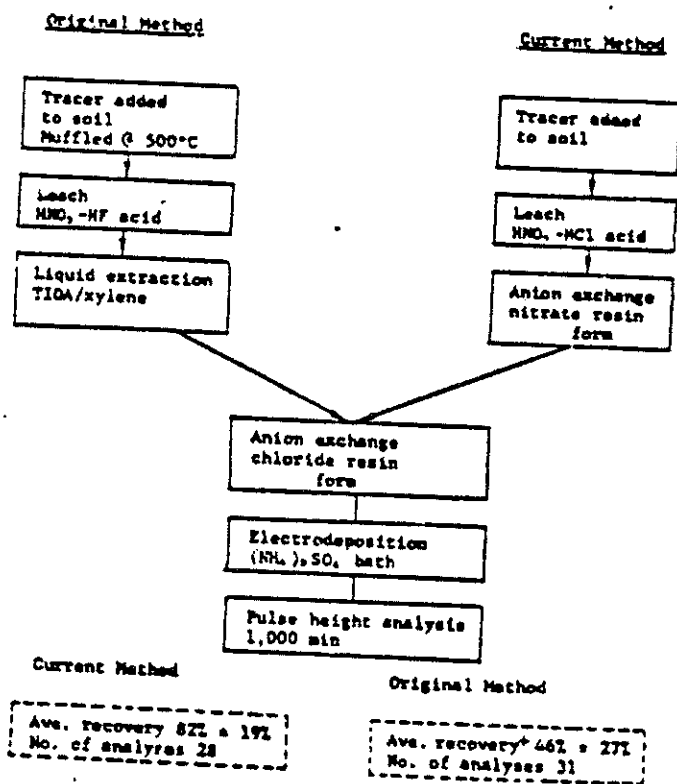

*The recovery is based only on those analyses performed for this study.

Fig. 1

Fusion Method

The fusion method used in this study is essentially identical to the method developed by C. W. Sill, et al.⁶⁻⁸ A summary of the procedure is given in Figure 2. This procedure involves fusing the soil with anhydrous

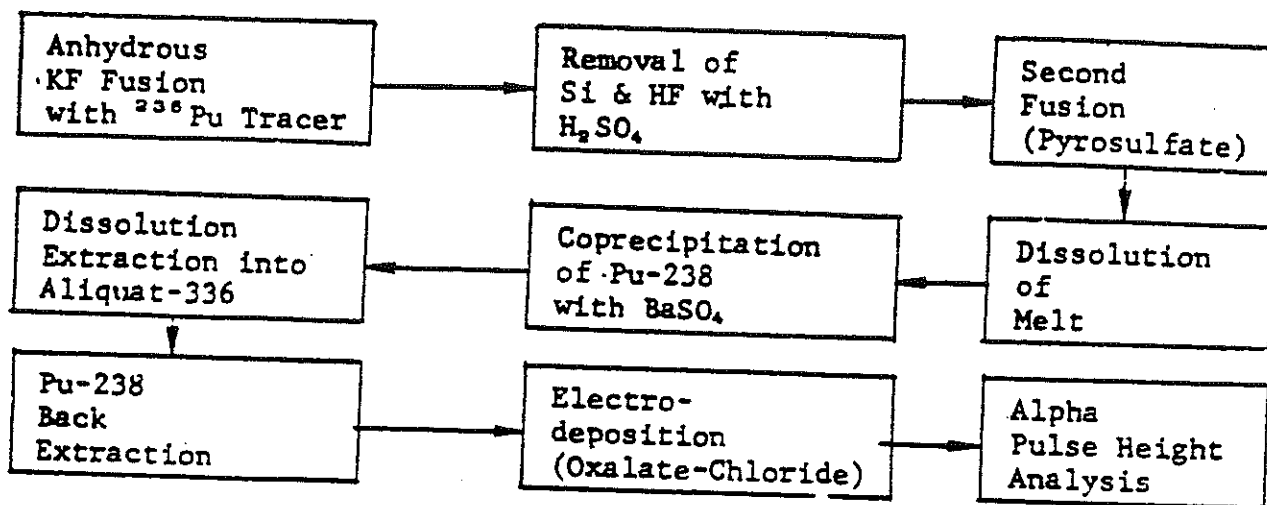

Fig. 2

potassium fluoride followed by a pyrosulfate fusion to completely decompose the soil. The solidified melt is dissolved with a potassium metabisulfate solution and the plutonium is separated from the solution by coprecipitation with barium sulfate. The barium sulfate is dissolved in an aluminum nitrate solution and the plutonium is extracted into Aliquat 336 (General Mills, Inc., Minneapolis, Minnesota) nitrate in xylene. Interfering metals are removed by back extraction before the plutonium is back extracted with an oxalic perchloric acid stripping solution. After evaporation to dryness and dissolution of the residue in a mixed oxalate-chloride electrolyte, the plutonium is electrodeposited by the procedure developed by K. W. Puphal and D. R. Olsen.⁹ The plutonium is finally determined by alpha pulse-height analysis utilizing a 4096 multichannel analyzer and 300 mm² surface barrier detector.

The ²³⁶Pu tracer in the fusion procedure indicated less than 80% recovery of plutonium. Tracer studies indicated greater than 95% recovery from the initial fusion of the soil, through the coprecipitation, the solvent extraction, and the preparation for electrodeposition. Electrodeposition efficiencies, however, were frequently much less than 95%. For this reason ²³⁶Pu tracer was used in all analyses of soil by the fusion procedure.

To evaluate the accuracy and precision of the fusion procedure two *standard* plutonium soil samples were analyzed. One sample was prepared at Mound Laboratory by spiking a soil sample with a standard solution of ²³⁸Pu, and the other was a soil sample spiked with ²³⁹Pu obtained from C. W. Sill. The results of the fusion analyses are given in Tables I and II. In both samples, the experimental average agreed to within a few percent of the standard value. The relative standard deviation of the

TABLE I
ANALYSIS OF A ²³⁸Pu "STANDARD"
SOIL SAMPLE BY THE FUSION METHOD

Sample Number	Weight of Sample (g)	²³⁸ Pu in Sample (Standard Value) (dis/min/g)	²³⁸ Pu in Sample (Found) (dis/min/g)	²³⁶ Pu Tracer Recovered (%)
A-1	1	36.4	36.0 ± 1.6 ^a	58
A-2	1	36.4	34.9 ± 1.7	45
A-3	1	36.4	41.2 ± 3.3	15.9
A-4	1	36.4	35.2 ± 1.6	18.6
A-5	1	36.4	35.4 ± 1.4	75
A-6	1	36.4	38.0 ± 1.4	65
S-51	20	36.4	35.3 ± 2.3	75
Average			36.6 ± 2.3 ^b	50 ± 24

^aStandard deviation based on counting statistics.

^bExperimental standard deviation based on the seven individual determinations.

TABLE II
ANALYSIS OF A ^{239}Pu SPIKED
SOIL SAMPLE^a BY THE FUSION METHOD

Sample Number	Weight of Sample (g)	^{239}Pu in Sample (Standard Value) (dis/min/g)	^{239}Pu in Sample (Found) (dis/min/g)	^{236}Pu Tracer Recovered (%)
1	1	35.42	33.48 ± 1.67^b	51
2	1	35.42	35.26 ± 1.49	57
Average			34.37	

^aStandard soil sample supplied to Mound Laboratory by C. W. Sill, Health Services Laboratory, U. S. Atomic Energy Commission, Idaho, Falls, Idaho.

^bStandard deviation based on counting statistics.

seven ^{238}Pu standard samples was 6.3%. As will be seen later this variation is low compared to the standard deviation observed with actual soil samples.

Control Analyses

Blank determinations were made periodically to examine the possibility of contamination from the reagents or glassware. In some cases, a ^{236}Pu tracer was added to determine the percent recovery when a blank value was determined. With both the leaching and the fusion techniques, the low blank was about 0.01 dis/min of ^{238}Pu . High blank values of 0.09 dis/min ^{238}Pu and 0.20 dis/min ^{238}Pu were observed for leaching and fusion, respectively. The average of 12 leaching blanks was 0.036 dis/min ^{238}Pu , while the average fusion blank value was 0.070 dis/min ^{238}Pu for 13 determinations. For most of the samples described in this report, the blank value is insignificant. For the analysis of soil samples having disintegration rates of the order of 0.01 dis/min/g or less, more stringent conditions would have to be observed in order to lower the blank values that are presently being observed.

Results and Discussion

The soil sample supplied to Mound Laboratory by C. W. Sill was also analyzed by the leaching method followed by analysis of the leached soil residue by the fusion method. Results of the analysis of two 1-g samples of this soil are given in Table III. It is clear that the leaching failed to remove all of the plutonium from the soil. The percentages of ^{239}Pu recovered from the spiked samples by leaching were 17 and 24%, respectively, while 81 and 78% of the activity was recovered by fusion of the soil residue. The total ^{239}Pu recovered from the two

samples, 34.6 and 36.1 dis/min/g, compares favorably with the spiked value of 35.4 dis/min/g. These data seem to indicate that the leaching method used here is inadequate for plutonium soil analysis. The preparation of the ^{239}Pu -spiked sample, however, involved heating the soil for a total of 4 h at 1000°C after the plutonium had been added. Thus it is possible that the plutonium reacted with the soil making leaching ineffective.

The data for the first of the four soil samples used in the intercomparison study are shown in Table IV. The plutonium concentrations obtained by both methods compare quite favorably. The ^{236}Pu tracer recovery was slightly higher for the fusion method.

Table V lists the data for the second soil sample used in the intercomparison. Here again the same general observations concerning the ^{236}Pu tracer recoveries can be made. The leach method gave slightly higher ^{238}Pu concentrations, but the standard deviations of the two sets of data overlap. The results of the third soil sample are shown in Table VI. Once again the same general observations can be made. Here the ^{236}Pu tracer recoveries by the fusion method were significantly higher with a much lower standard deviation than obtained in the leach analysis; however, the averages for the plutonium concentrations show good agreement. This set of data, as well as the data obtained on the previous two soil samples clearly show the need for the use of ^{236}Pu tracer in these analyses.

Table VII shows the data on the fourth soil sample. Here the average ^{238}Pu concentrations do not show as good agreement as the previous samples although from the spread in the individual determinations, especially with the fusion results, it cannot be concluded that the results disagree. It should be noted in Table VII that aliquots of 50, 20, and 10 g were analyzed and that as the aliquot size decreased the standard deviation increased. The overall average value for the 11 leached samples was 13.9 ± 4.7 dis/min/g. The average value for 50-g aliquots

TABLE III
ANALYSIS OF A ²³⁹Pu SPIKED SOIL SAMPLE^a
BY LEACHING AND FUSION

<u>Sample Number</u>	<u>Aliquot Analyzed (g)</u>	<u>²³⁹Pu Removed by Leaching (dis/min/g)</u>	<u>²³⁹Pu Found in Leach Residue (dis/min/g)</u>	<u>Total Recovered (dis/min/g)</u>
1	1	5.9 (17%)	28.7 (81%)	34.6
2	1	8.6 (24%)	27.5 (78%)	36.1

^aSpiked soil sample (35.4 dis/min/g) supplied to Mound Laboratory by C. W. Sill, Health Services Laboratory, Idaho Falls, Idaho.

TABLE IV
²³⁸Pu DISINTEGRATION RATES IN SOIL SAMPLE NO. 1
BY LEACHING AND FUSION

<u>²³⁸Pu by Leaching (50-g aliquot)</u>		<u>²³⁸Pu by Fusion (10-g aliquot)</u>	
<u>(dis/min/g)</u>	<u>(% ²³⁸Pu recovery)</u>	<u>(dis/min/g)</u>	<u>(% ²³⁸Pu recovery)</u>
0.040	16	0.051	58
0.027 ^a	62	0.034	71
0.039 ^a	58	0.037	56
0.038 ^a	43	0.036	42
0.038 ^a	46		
0.031 ^a	71		
0.050	94		
0.045	12		
Ave. <u>0.039</u>	50	<u>0.040</u>	57
Std. Dev. ± 0.007	± 27	± 0.008	± 12

^aBased on the analysis of an aliquot of a leach solution from a 1000-g sample.

TABLE V
²³⁸Pu DISINTEGRATION RATES IN SOIL SAMPLE NO. 2
 BY LEACHING AND FUSION

<u>²³⁸Pu by Leaching (50-g aliquot)</u>		<u>²³⁸Pu by Fusion (10-g aliquot)</u>	
<u>(dis/min/g)</u>	<u>(% ²³⁶Pu recovery)</u>	<u>(dis/min/g)</u>	<u>(% ²³⁶Pu recovery)</u>
0.104	42	0.203	54
0.255	25	0.164	58
0.219	11	0.144	71
0.194	77	0.186	70
0.266	30		
0.148	111		
Ave. <u>0.198</u>	49	<u>0.174</u>	63
Std. Dev. ± 0.063	± 38	± 0.026	± 9

TABLE VI
²³⁸Pu DISINTEGRATION RATES IN SOIL SAMPLE NO. 3
 BY LEACHING AND FUSION

<u>²³⁸Pu by Leaching (50-g aliquot)</u>		<u>²³⁸Pu by Fusion (10-g aliquot)</u>	
<u>(dis/min/g)</u>	<u>(% ²³⁶Pu recovery)</u>	<u>(dis/min/g)</u>	<u>(% ²³⁶Pu recovery)</u>
1.66	22	1.75	81
1.81	13	2.06	82
1.46	23	1.41	81
1.97	100	1.34	73
1.30	63	1.38	77
1.58	89		
Ave. <u>1.63</u>	52	<u>1.59</u>	79
Std. Dev. ± 0.24	± 38	± 0.31	± 4

TABLE VII

²³⁸Pu DISINTEGRATION RATES IN SOIL SAMPLE NO. 4
BY LEACHING AND FUSION

²³⁸ Pu by Leaching			²³⁸ Pu by Fusion		
(dis/min/g)	(aliquot, g)	(% ²³⁸ Pu recovery)	(dis/min/g)	(aliquot, g)	(% ²³⁸ Pu recovery)
16.41	50	48	11.49	10	86
15.90	50	25	16.58	10	84
14.56	50	40	11.28	10	87
10.05	20	41	11.67	10	93
11.05	20	24	65.2	10	89
24.31	20	40	25.35	10	75
9.52	20	31	9.85	10	76
14.09	20	36	56.4	10	63
9.92	20	51			
8.97	20	41			
18.09	20	49			
Ave. 13.90		39	26.0		82
Std. Dev. ± 4.7		± 9	± 22.2		± 10

was 15.62 ± 0.96 dis/min/g, for 20-g aliquots 13.3 ± 5.4 dis/min/g, and for 10-g aliquots 26.0 ± 22.2 dis/min/g.

A summary of the ²³⁸Pu disintegration rates for the four soil samples analyzed is given in Table VIII. There is good agreement between the average ²³⁸Pu disintegration rates for the first three samples indicating good agreement between fusion and leaching. Even with sample number 4 where the averages are 26.0 and 13.9 dis/min/g, considering the large standard deviation as stated previously, it cannot be concluded that the results do not agree. The

larger fusion value could well have been caused by the fact that two of the samples taken for fusion analysis contained a relatively large individual particle of plutonium dioxide. A single ²³⁸PuO₂ particle 1.35 μm in diam would add about 500 dis/min to a soil sample. This would increase the concentration of activity in a 10-g sample by 50 dis/min/g, while the effect on a 50-g sample would be only 10 dis/min/g. Thus, it is possible that the two samples giving a high ²³⁸Pu concentration contained a relatively large plutonium dioxide particle while the other sample did not. It should be noted that the average fusion

TABLE VIII

SUMMARY ²³⁸Pu DISINTEGRATION RATES
BY LEACHING AND FUSION

Sample Number	Leaching Procedure			Fusion Procedure		
	²³⁸ Pu (dis/min/g)	Rel. Std. Dev. (%)	No. of Samples	²³⁸ Pu (dis/min/g)	Rel. Std. Dev. (%)	No. of Samples
1	0.039	18	8	0.040	20	4
2	0.198	34	6	0.174	15	4
3	1.63	15	6	1.59	19	5
4	13.9	34	11	26.0	85	8

value is 14.4 dis/min/g when these two high values are not used in calculating the average. This average compares quite favorably with the leaching value of 13.9 dis/min/g.

This particle size problem is more severe when analyzing for ^{238}Pu as compared to ^{239}Pu because of the considerable difference in specific activity between these two isotopes. Plutonium-238 has a specific activity of 3.81×10^7 dis/min/ μg compared to 1.36×10^5 dis/min/ μg for ^{239}Pu . It should also be noted that in all of the fusion results the relative standard deviation is greater than the standard deviation that was obtained when the spiked soil sample was analyzed (6.3%). This indicates a sampling error which could also be explained by the existence of small ^{238}Pu particles in the soil.

As a further study on a possible difference between the leaching and fusion procedures in determining ^{238}Pu in soil, residues from eight 20-g samples of soil sample number 4, analyzed by the leaching procedure, were analyzed by the fusion procedure. The results are given in Table IX. With this soil sample, it is seen that on the average approximately 93% of the ^{238}Pu is leached from the soil. Also the fact that these eight analyses showed an average tracer recovery of 39%, not including the leaching operations, suggests that the major losses in the original leach procedure were not in the leach step but, rather, in the chemistry that follows.

In conclusion it appears that the leaching and fusion methods in the present study for the determination of ^{238}Pu in soil agree. However, additional data will be

accumulated in order to evaluate this assumption. Future plans include the analysis of additional leached soil samples by the fusion procedure to determine whether or not leaching has failed to remove significant amounts of plutonium from the original soil sample.

Acknowledgments

The authors would like to acknowledge the assistance of the personnel at Mound Laboratory who contributed to the determination of the data presented in the report: M. L. Curtis, R. Brown, K. E. DeVilbiss, J. A. Doty, L. C. Hopkins, V. C. Lacy, L. G. Musen, E. B. Nunn, R. L. Ryan, and F. K. Tomlinson. We would also like to acknowledge John H. Harley, Director, the New York Operations Health and Safety Laboratory of the U. S. Atomic Energy Commission for supplying Mound Laboratory with the ^{236}Pu tracer and for helpful discussions on the leaching method. Finally, we also acknowledge Dr. C. W. Sill and the Health Services and Safety Laboratory of the U. S. Atomic Energy Commission at Idaho Falls, Idaho, for supplying us with information on the determination of plutonium in soil by a fusion method.

References

1. J. H. Harley (Ed.), Health and Safety Laboratory Manual of Standard Procedures, U. S. Atomic Energy Commission NYO-4700, Rev. 1970.

TABLE IX
 ^{238}Pu DISINTEGRATION RATES IN
LEACHED RESIDUES OF SOIL SAMPLE NO. 4

Sample Number	^{238}Pu Leached ^a (dis/min/g)	^{238}Pu in Leached Soil by Fusion ^b (dis/min/g)	Total ^{238}Pu in Sample (dis/min/g)	^{238}Pu Recovered by Leaching (%)
4-4	10.05	1.10	11.15	90.1
4-5	11.05	1.01	12.06	91.6
4-6	24.31	0.74	25.05	97.1
4-7	9.52	1.13	10.65	89.4
4-8	14.09	1.16	15.25	92.4
4-9	9.92	0.68	10.60	93.6
4-10	8.97	0.62	9.59	93.5
4-11	18.09	1.18	19.27	93.9
Average	13.25	0.95	14.20	92.7
Std. Dev.	± 5.41	± 0.23	± 5.41	± 2.4

^a ^{236}Pu tracer recoveries averaged $39 \pm 9\%$ for leaching.

^b ^{236}Pu tracer recoveries averaged $76 \pm 5\%$ for fusion.

2. F. E. Butler, "Determination of Uranium and Americium-Cerium in Urine by Liquid Ion Exchange," *Anal. Chem.*, Vol. 37, pp. 340-342 (1965).
3. L. C. Henley, "Urinalysis by Ion Exchange," presented at the Eleventh Annual Bio-Assay and Analytical Chemistry Conference, Albuquerque, New Mexico, October 7-8, 1965.
4. I. A. Dupzyk and M. W. Biggs, "Urinalysis for Curium by Electrodeposition," presented at the Sixth Annual Meeting on Bio-Assay and Analytical Chemistry, Santa Fe, New Mexico, October 13-14, 1960.
5. N. Y. Chu, "Plutonium Determination in Soil by Leaching and Ion Exchange Separation," *Anal. Chem.*, Vol. 43, pp. 449-452 (1971).
6. C. W. Sill and K. W. Puphal, "The Determination of Plutonium in Soil," to be published, (Health Services Laboratory, U. S. Atomic Energy Commission, Idaho Falls, Idaho).
7. C. W. Sill and R. L. Williams, "Radiochemical Determinations of Uranium and the Transuranium Elements in Process Solutions and Environmental Samples," *Anal. Chem.*, 41, 1624 (1969).
8. C. W. Sill, "Separation and Radiochemical Determination of Uranium and the Transuranium Elements Using Barium Sulfate," *Health Physics*, 17, 89 (1969).
9. K. W. Puphal and D. R. Olsen, "Electrodeposition of Alpha-Emitting Nuclides from a Mixed Oxalate-Chloride Electrolyte," to be published, (Health Services Laboratory, U. S. Atomic Energy Commission, Idaho Falls, Idaho).

COMMONALITY IN WATER, SOIL, AIR, VEGETATION, AND BIOLOGICAL SAMPLE ANALYSIS FOR PLUTONIUM

by

Robert A. Wessman, W. J. Major, Kim D. Lee, and L. Leventhal
TRAPELO/WEST
Division of LFE Corporation
Richmond, California

ABSTRACT

have been performed at Trapelo/West for over twenty years. Procedural changes have been made to obtain commonality in analyzing Pu in different matrices. Procedures used for Pu in matrices such as water, soil, air, vegetation, and biological and chemical are discussed. Initial steps involve total dissolution, leaching or extraction with tracer ^{239}Pu . Tracer is used in all cases since it provides reliable data. An anion exchange procedure is the basic part of the method. An efficient electrodeposition step permits plating in ten minutes. Activity measurements are made using either Frisch Grid Ionization or surface-barrier detectors. Problems likely to be encountered in plutonium analysis are discussed. Problems encountered in measuring and stating error limits at very low levels so that they may be used practically are discussed.

Analytical System

Trapelo feels that the entire analytical system used must be considered as a whole. This is even more important in radiochemistry than in routine analytical chemistry. Chemistry procedures, though most often stressed, are only a portion of the total.

In a small laboratory, the system might consist of only one worker and related equipment and procedures. At another facility, such as Trapelo, the responsibilities might be spread out according to the expertise of each person.

The Trapelo Laboratory System for Plutonium. What is considered, at Trapelo, to be the key to the analysis of the actinides, particularly plutonium, is listed (Fig. 1) and outlined in further detail below.

Radiochemical analyses have been performed at Trapelo/West for over twenty years. Major improvements have resulted from increased knowledge of the tracer and the availability of extraction chemicals and reagents and improved nuclear measurements. Improvements have been gradual and metamorphic rather than sensational. The net effect has still been dramatic. At one time the laboratory had its own *calibrated radiochemists*. Use of low-level, high-resolution alpha spectrometry have permitted the greatest improvements. The present state of the art permits practical measurements to a counting error of $\pm 5\%$ at levels as low as $1\frac{1}{2}$ dpm for a 10-min count. That can be reduced to $\frac{1}{2}$ dpm if three-minute detector time per sample is available, etc.

FIGURE 1
KEY REQUIREMENTS FOR PLUTONIUM ANALYSIS

1. Personnel
2. Low Level Lab and Equipment
3. Solubilization (or Leach) of Pu
4. Accurately Standardized ²³⁶Pu Tracer
5. Equilibration
6. Decontamination and Purification
7. Alpha Spectrometer System
8. Standard Data Calculation
9. Quality Control

1. PERSONNEL

- a. Experienced in use of procedures
- b. Flexibility in doing different analyses

2. LOW LEVEL LABORATORY AND EQUIPMENT

- a. Low Level control
- b. Good housekeeping

3. SAMPLE SOLUBILIZATION (OR LEACH)

- a. Specific procedures for different matrices

4. ACCURATELY STANDARDIZED PLUTONIUM-236 TRACER

- a. Against an absolute basis
- b. Precision of $\pm 1.5\%$
- c. ²³⁶Pu impurity ≤ 0.5 alpha %
- d. ²³⁹Pu impurity ≤ 0.09 alpha %
- e. Impurity content known for correction purposes

5. EQUILIBRATION

- a. Exchange with tracer during solubilization or subsequently

6. DECONTAMINATION AND PURIFICATION

- a. The minimum chemistry to obtain weightless electrodeposit
- b. Chemistry tested to remove other actinides
- c. Obtain radiochemical yields of 40 to 90%

7. ALPHA SPECTROMETER SYSTEM

- a. Frisch Grid or surface barrier
- b. Resolution 20 to 40 keV
- c. Efficiency 30 to 48%
- d. No tailing of peaks at baseline

8. STANDARD DATA CALCULATION

- a. Consistent interpretation of spectra
- b. Realistic assessment of precision

9. QUALITY CONTROL AND EVALUATION

- a. Routine blanks and standards
- b. Alpha spectrometer checks on background efficiency, etc.

Basic Procedures

The basic procedures used at Trapelo/West for low-level plutonium are, in many aspects, similar to those used at many other laboratories. The analyst has a wealth of proven analysis sequences to choose from in assembling a set for routine use in his own laboratory. Figure 2 is a schematic showing how different sample matrices fit into the processing.

Sample Preparation. The preparation of samples for analysis at Trapelo follows generally accepted practice using drying, ashing, grinding, etc. At Trapelo, the specimens may be received at the analysis laboratory in various states of preparation, ranging from a raw sample to an ashed residue.

Sample Solubilization. Solubilization of the sample is a critical part of plutonium analyses using tracer. Indeed, much time is spent in achieving this. Within a sample category, maverick samples are always found which will not completely dissolve by routine treatment. The radiochemist treats these individually to dissolve residuals. Usually HNO₃-HCl-HClO₄-HF or fusion is used.

In the special case of soil leaching, the procedure of Norton Chu of HASL¹ is used and of course complete solution of the soil is not expected.

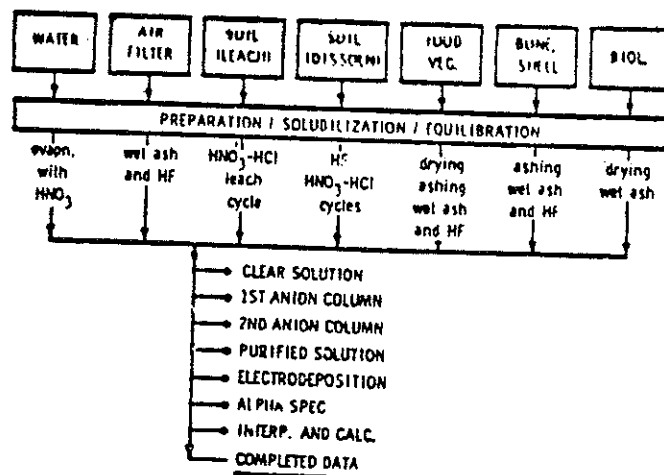

Fig. 2

Chemical Procedures. We wish to attain a unified procedure for environmental-type samples. After the samples have been solubilized, it is possible to use the same purification steps for the remainder of the analyses. The steps used are not severely influenced by the original sample matrix or the amount of sample. This commonality of methods minimizes having to cope with many different procedures. Also, less special equipment and special work areas are required, different sample types can be processed simultaneously, and less training and break in of laboratory personnel is required.

The salient features of the chemical procedures used at Trapelo are outlined in Fig. 3. The unifying steps are anion exchange, evaporations, and boiling. The anion exchange procedure is very similar to that used in the soil leach procedure of Chu, who credits his scheme to one suggested by the work of Kressin and Waterbury.²

The ability to use ion exchange and exclude precipitations, especially bulky alkaline precipitations with phosphates, etc., is very desirable.

Features of the exchange method are that the solubilized sample, in a volume of 200 to 1500 ml of approximately 6N HNO₃, is processed by two sequential anion exchange columns (Dowex 1-X4) to achieve a solution from which plutonium can be electrodeposited for alpha spectroscopy.

The first column is largest, its size depends somewhat upon the volume of dissolved sample. Leachate from 100 g of soil requires a column 2.5-cm diam by 6 cm. If a 1000-g sample is leached, the column length is increased

to 12 cm. The actinides Th(IV), Pa(V), U(IV), Np(IV), and Pu(IV) are absorbed by the resin while trivalent Ac, Am, and Cm pass through. The retained actinides can be eluted with 4N HNO₃-0.1N HF (Chu reports use of 0.4N and 0.01N respectively.)

The second, smaller-sized anion column (1-cm diam by 2.5 cm) is used for final clean up of the solution. Again the sample, in 6N HNO₃, is loaded onto the column. The resin is then converted, successively, with 6N HCl and concentrated HCl to the chloride form. Any Th would elute in the HCl fractions. An eluent³ of HCl containing NH₄I is used to reduce and elute Pu(III). This provides plutonium free of any alpha emitting actinides such as Th, Pa, U, or Np. If there is a very large amount of Fe(III) or other oxidant, the first column purification should be repeated prior to the HNO₃-HCl column.

Electrodeposition. After evaporation and wet-ash destruction of trace organics, the plutonium is electrodeposited upon a stainless steel disc (220-mm diam, 250-mm² plated area). Platinum discs are used for highest accuracy. The ammonium chloride method described by Mitchell⁴ is used. This plating method has been in use at Trapelo for many years and is recommended as a reliable procedure which is essentially quantitative with only a 10-min plating time.

Very clean, almost invisible plated areas are obtained if the purification is done properly. The stainless steel discs should not be flamed after plating since an oxide coating forms which degrades the alpha spectra.

Alpha Spectrometry. Samples are counted on a detector in either a battery of Trapelo Frisch grid detectors or a battery of Ortec 450-mm² surface-barrier detectors. The grids operate on argon-methane (P-10 gas) while the surface-barrier detectors are operated in a vacuum. Resolution of the gridded detectors are as low as 20 keV at 5.75 MeV. The same Frisch grid chambers in 1963 had only 45-keV resolution, a two-fold improvement having been attained by modification of the electronic components. Resolution of the surface barriers is 50 keV.

Background in the ²³⁹Pu energy peak varies between 0.004 to 0.018 for the different detectors. Background fluctuations are due primarily to statistical variations but can be increased by counter contamination from certain isotopes. Melgard⁵ discussed internal contamination of alpha spectrometers due to counting different isotopes. On the Frisch grids, collimators are used to reduce baseline tailing. This also reduces counting efficiency from 48 to 35%. Efficiency on the solid-state detectors is 28 to 30%.

Calculations. Calculation of alpha spectrometry data is presently done using a combination of computer and hand calculations. A smoothed alpha spectrum plot is produced by the computer, incorporating an energy calibration line from standards counted with the specific sample. The plot is examined to determine the isotopes

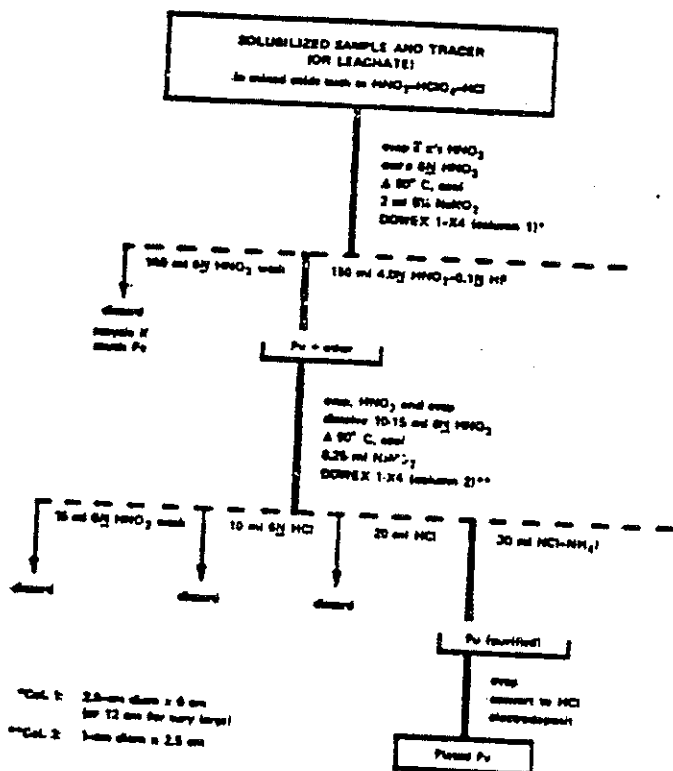

Fig. 3

present in the sample and the alpha peaks are then integrated within preselected energy regions. Corrections for background as well as apparent impurities from the ^{236}Pu tracer are made.

Errors of analysis are estimated conservatively and all errors are included which could significantly affect the users' confidence in the data. This treatment becomes most significant at low (< 1 dpm) activity levels. Rather than use simple counting statistics, the error associated with correcting for background, blank, and tracer contribution, is estimated at somewhat greater than that error indicated by counting statistics alone. This method also assumes that some of the errors are not Gaussian and there is, therefore, an increased uncertainty.

Operational Experience

Experience with this procedure is discussed relative to tracer yields, isotope purity, and other operational aspects.

Yields. Chemical yields are generally good. Figure 4 shows yields for several different biological organs ranging in weight from 20 to 600 g. There does not seem to be any dependency upon weight. The lower yields for the nodes are not believed related to sample type.

Yields for leach analyses of various size aliquots of soil are shown in Fig. 5. Different soils are included but no correlation of yield with soil type has been made. The lower yields primarily represent some of the first soils analyzed in a given weight range. Some of the unexpected difficulties were usually ironed out. The yield from 1-kg soil leaches and 100-g dissolutions are now expected to be in the 70 to 80% range.

Purity of Plutonium Plates. Natural and other artificially produced alpha emitters are often present in

environmental samples analyzed for plutonium. If not removed, ^{228}Th and ^{241}Am will perturb the ^{238}Pu alpha peak. Thorium-227 would perturb the ^{236}Pu tracer peak. Uranium-232, a growth in ^{236}Pu tracer, is also added to each sample. There are other possible contaminants of minor importance.

An evaluation of the procedure for decontamination from four actinide elements was performed. The plutonium fraction was examined for impurities on the alpha spectrometer.

The results are shown in Fig. 6. The amount of impurities on each plate was close to limits of detection. An estimate of lower limits for the decontamination factors was made and all were greater than or equal to 2×10^3 . More exact factors could be determined but larger amounts of impurity isotopes must be used.

The decontamination factors obtained indicate the procedure is more than adequate for any expected environmental samples.

Operational Aspects. This scheme of analysis appears to have the desired flexibility. The commonality of methods is not new but the present scheme seems to provide better unification than we have experienced before.

As an example, Trapeln previously used a unified system for processing thousands of biologicals, soils, vegetation, and various collection media. The methods were reported by W. Major^{3,4} The chemical procedure consisted of a cupferron extraction, a hydroxide precipitation from a basic carbonate media, and another precipitation from NH_4OH . An anion exchange column purification, very similar to the second column used in this report, was used as final cleanup. Excellent results were obtained using those procedures but they contained some messy, intermediate steps, i.e. the organics from the extraction had to be destroyed by wet ashing. They were also more time consuming.

FIGURE 4
TRACER YIELD FROM BIOLOGICAL ORGANS

Organ	Aliquot g	Tracer Yields Av. of Duplicates
Kidney	60	87%
Heart	65	80%
Rib	30	70%
Node	20	38%
Spleen	560	72%
Lung	210	77%
Liver	620	98%**
Reagent Blank*	--	91%

*Blank results 0.0 to 0.01 dpm ^{239}Pu .

**Cracked beaker caused 20% yield on a liver.

FIGURE 5
TRACER YIELD FROM SOILS

Sample Size g	No. Samples	Yields Range	Average	Remarks
		Leaching		
100	10	28-82%	60%	
100	5	28-62%	45%	
100	5	18-76%	53%	
1000	12	8-68%	32%	
1000	13	30-88%	60%	Early work
500	6	72-94%	80%	Later work*
		Dissolution		
100	5	42-88%	75%	

*Two difficult soils with 10% yields not included.

FIGURE 6
DECONTAMINATION FACTORS FOR Pu PROCEDURE
(Tested on Duplicate Runs)

Impurity*** Isotope	Added dpm	Found on Pu Discs		Estimated Deccontam. Factor
		Individual dpm	Av. dpm	
²³⁰ Th	429	0.06	0.13	$> 3 \times 10^3$
		0.20		
²³¹ Pa	700	0.08	0.06	$> 10 \times 10^3$
		0.05		
²³³ U	532	0.12	0.30	$> 2 \times 10^3$
		0.46		
²⁴¹ Am	467	0.06	0.06	$> 8 \times 10^3$ **
		0.00		

*Results corrected by Pu tracer yield.

Cm decontamination will be similar to Am. *Potential interference in Pu alpha spec would be:

Pu peak - Am, U (minor)
Pu peak - Th, Am
Pu peak - Th, Cm

Specific Problems in Low Level Plutonium Analysis

A few specific problems related to low-level plutonium analysis are given. These are mutual problems faced by analysts and which affect the ultimate data users.

Low-Level Aspect. High-level plutonium samples sometimes appear unexpectedly in analysis programs. Sometimes they have been prepared as program evaluation spikes or other tests. They are a definite contamination hazard to other samples when this is not known ahead of time. In a program with mixed levels, a pre-monitoring system must be set up as was done in past soil analysis programs.⁶

At this laboratory, low-level laboratory operations suffice for analysis of samples ranging from zero to approximately 100 dpm. The greatest barrier to cross contamination is the use of new glassware, especially on low-level samples. If the project work does not merit this added expense, then second-hand glassware from projects of similar or lower level can be used. Used glassware introduces another variable since cleaning procedures may not be perfect. Other sources of cross contamination, such as reagent bottles, centrifuges, platters, etc. must be minimized by good housekeeping. Effectiveness of such operations must be monitored by processing blanks with each batch of samples.

Plutonium-236 Tracer. The key to accurate analyses at many laboratories is use of ²³⁶Pu tracer. Stocks of tracer available have been found to contain a slight apparent contamination of ²³⁸Pu (0.2 to 0.5 alpha %) and ²³⁹Pu (0.04 to 0.09 alpha %). The contamination increases relatively with time, almost proportional to the 2.8-yr ²³⁶Pu decay. Tracer purchased in late 1970 from the USAEC, Oak Ridge tests no better than our previous stock (produced in 1963).

The most serious effect is in the analysis of ²³⁸Pu. The amount of correction needed is difficult to determine accurately. Use of very small amounts of tracer (3 dpm) minimizes the correction but longer counting times are required. An alternate method, in a sample with measurable ²³⁹Pu content, is to split the sample and analyze one part, with tracer, to obtain the ²³⁹Pu content and the second part, without tracer, to obtain a less unperturbed ²³⁸Pu/²³⁹Pu ratio.

Evaluation of Analytical Quality. Radiochemists may expound upon very good tracer yields and relate them to analytical quality. Data users may be unduly influenced and give high-yield data weight over average yields.

In low-level plutonium analysis, a good yield means that signal-to-background ratio and figure of merit for a given sample is being maximized. This is important, but a very high yield, say 96%, may be an artifact, particularly in diode counting. It should not outweigh a yield of 80% or even 50%.

Meigard discussed the factors affecting the efficiency of both Frisch grid and surface-barrier detectors. Non-uniformity of plating can result in a 20% variation in counting efficiency on s.b. detectors. Sample positioning has a large effect on efficiency at short sample-to-detector distances used on surface barriers. The error is greater for smaller detectors. Frisch-grid efficiency is insensitive to these variations. Thus yields on surface-barrier detectors may not be absolute, but since yield cancels in isotope dilution analysis, this is not important. At Trapelo, tracer yields are considered accurate to $\pm 3\%$ on Frisch grids and $\pm 5\%$ on the 450-mm² surface barriers. Thus, a sample with 96% yield on solid state could measure 88% yield on a Frisch grid, with no harm, except to the self esteem of the radiochemist.

Summary

A commonality in methods of low level plutonium analysis in environmental samples at Trapelo/West has been briefly described. Emphasis has been placed upon aspects considered most important to obtain accurate results. The system of analysis at a given laboratory is considered to be most important.

Providing certain primary operations are accomplished in an analysis, intermediate processing steps assume secondary importance, provided tracer yields are reasonable.

Most important is use of an absolutely standardized plutonium tracer and equilibration in the sample. As sample activity levels decrease, spectra interpretation and data calculation methods assume greater importance. The data user should use low level data with large error limits with caution. In the haste of project analysis, data users rather tend to disregard error limits.

Large error limits, calculated by routine statistical methods, should be verified in empirical tests such as dilution experiments, blanks, etc.

With these considerations, it is recommended that promulgation of *approved methods* by any agency group or project be done with caution. That flexibility of methods be allowed to each laboratory system and that emphasis for *correctness* be placed upon obtaining the same results on the same material by independent laboratory systems. This is already the basis of operation for some of the most successful data-gathering systems in the nation.

References

1. Norton Y. Chu, "Plutonium Determination in Soil by Leaching and Ion-Exchange Separation," *Anal. Chem.* 43, 449-542 (1971).
2. I. K. Kressin and G. R. Waterbury, "The Quantitative Separation of Pu from Various Ions by Anion Exchange," *Anal. Chem.* 34, 1598-1601 (1962).

3. W. J. Major, R. A. Wessman, R. Melgard and L. Leventhal, "Routine Determination of Pu by Tracer Techniques in Large Biological Samples," Health Phys. 10, 957-965 (1964).
4. R. F. Mitchell, "Electrodeposition of Actinide Elements at Tracer Concentrations," Anal. Chem. 32, 326-328 (1960).
5. R. Melgard, R. A. Wessman and L. Leventhal, "The Relative Advantages of Gas and Diode Detectors in Low Level Alpha Spectroscopy," 14th Annual Bioassay and Analytical Chemistry Meeting, New York City, Oct. 7-8, 1968.
6. W. Major, R. Wessman, R. Melgard and L. Leventhal, "Routine Determination of ^{239}Pu in Fused Soil Lattices by Tracer Techniques," Tenth Annual Meeting Health Physics Society, Los Angeles, Calif., June 1965.

THE PARTICLE PROBLEM AS RELATED TO SAMPLE INHOMOGENEITY

by

Claude W. Sill
Health Service Laboratory
U. S. Atomic Energy Commission
Idaho Falls, Idaho

ABSTRACT

The effect of the specific activity of single particles of various sizes on the comparative homogeneity of plutonium distribution in soil samples is discussed.

Information is presented on the relative efficacy of leaching procedures versus total sample decomposition as a function of particle size and origin.

The activity of N spherical particles of pure $^{239}\text{PuO}_2$ is $0.721 N D^3$ dpm where D is the diameter of the particle in microns. Because the activity is proportional to the third power of the diameter, a ten-fold increase in diameter gives a thousand-fold increase in activity. If the activity is low, as is presently true with average soils, the entire activity could have resulted from a very few particles of reasonable size, making reproducible sampling virtually impossible. For example, a single $1\text{-}\mu$ particle in 10 g of soil gives an average activity of 0.072 dpm/g. Levels around 0.04 dpm/g are widely encountered in the environment, while levels as high as 1 dpm/g have caused considerable concern among some critics. These levels could have resulted from single particles having diameters of 0.82 and $2.4\ \mu$, respectively, in 10 g of soil. A single large particle would contribute as much activity as a thousand smaller ones with one-tenth the diameter. Consequently, different solid aliquots of the same sample submitted for analysis could give results differing by many orders of magnitude depending on the number of particles present and their size distribution in each aliquot. Larger samples would obviously help obtain a more representative mean but would not eliminate the problem.

In laboratory measurements of the characteristics of aerosols resulting from small-scale burning of plutonium metal and alloys, Ettinger et al.¹ found mass median diameters (mmd) of 0.03 to $0.14\ \mu$. They also quote work of others giving mmd's of several μ for other conditions. Mishima and Schwendiman² found a mmd of $4.2\ \mu$ for aerosols from ignition of large metal ingots in moderate

airflows, and mmd's up to $60\ \mu$ for the airborne material resulting from heating dry plutonium compounds in flowing air streams. Similarly, Kelkar and Joshi³ found plutonium particles with a median diameter of $1.1\ \mu$ in a laboratory handling plutonium compounds. It seems entirely reasonable to expect severe sample inhomogeneity at short distances from plutonium facilities, particularly if the activity levels are high, and a detectable problem even at considerable distances. Fowler et al.⁴ show results varying from 0 to 778 dpm/g in a single soil sample collected near the impact area of an aircraft carrying a nuclear device.

On the other hand, if the particles are even as small as $0.1\ \mu$ at least 556 particles of the pure oxide would be required in a 10-g sample to produce an average level of even 0.04 dpm/g. Such a large number of small particles should permit the sample submitted for analysis to be homogenized and sampled better than the statistical uncertainty associated with either the subsequent analysis or the environmental sampling itself. However, most of the globally-distributed plutonium results from detonation of nuclear devices that give particles only a few $m\mu$ in diam,⁵ an extremely large number of which would be required to account for the observed activity. Furthermore, material from the detonation of nuclear devices will have been completely vaporized and recondensed giving particles containing a very small fraction of plutonium rather than separate, discrete particles of the pure oxide. Consequently, little inhomogeneity of consequence might be expected on soils containing only plutonium from global fallout, even on only 10-g samples.

Although few in number, the experimental data shown in Table I appear to substantiate the correctness of the above reasoning. The first two samples were obtained near a plutonium facility, but one which was not known to have released any plutonium to the environment. Samples 3 through 7 were obtained at distances of about 2.0, 2.0, 16, 17 and 43 miles, respectively, downwind from a plutonium processing facility known to have released a significant quantity of plutonium. Samples 8 and 9 were taken at distances of about 50 miles and 100 yards, respectively, from two other facilities known to have released plutonium. Every result obtained on samples 1, 2, and 7, and all but one result each on samples 5, 6, and 8 are well within the statistical uncertainty of the analyses on 10-g samples. The plutonium present probably resulted entirely from global fallout. However, the single, high values in samples 5, 6, and 8 are 1.5 to 4 times the other values in the same sample and clearly represent a significant difference in that particular aliquot, possibly caused by a single, larger particle. The results on samples 3 and 9 show the pronounced heterogeneity to be expected on samples taken relatively close to the source where larger particles might be expected. Samples 3 and 4 were taken at greater distances than sample 9 but the source was much larger and the area is subject to fairly high winds.

The particle problem becomes particularly acute with $^{238}\text{PuO}_2$ for which the numerical constant in the above activity-particle size relationship is 202. In a 10-g sample, single particles of 0.1- and 1- μ diam give average activities of 0.02 and 20.2 dpm/g, respectively. Consequently, even low-activity samples might be expected to give extremely erratic results occasionally due to sample inhomogeneity, particularly in the vicinity of facilities handling ^{238}Pu where larger particles might be encountered. In one such example, the ratio of ^{238}Pu to ^{239}Pu changed from 1.6 to 0.15 on two separate aliquots of the same sample showing conclusively the presence of discrete particles of different composition.

The numerical constant in the activity-size expression above is only 6.94×10^{-4} for a highly enriched UO_2 containing 1% $^{234}\text{UO}_2$ and 99% $^{235}\text{UO}_2$. A single particle of 10- μ diam would produce activity in 10 g of soil of only 0.069 dpm/g. Consequently, relatively larger particles are required to produce significant activity in a few particles and the particle problem is expected to be relatively small for uranium oxide, even when highly enriched. The constants are 8.03×10^{-3} for $^{237}\text{NpO}_2$ and 41.1 for $^{241}\text{AmO}_2$, giving rise to particle problems intermediate to those described above.

References

1. H. J. Ettinger, W. D. Moss, and H. Busey, Nucl. Sci. Eng., 30, 1 (1967).

TABLE I
REPRODUCIBILITY OF ANALYSES USING
10-GRAM ALIQUOTS OF PREPARED SOILS

Number	Pu found, (dpm/g)
1	0.110 \pm 0.009
	0.116 \pm 0.010
	0.112 \pm 0.012
	0.101 \pm 0.008
	0.111 \pm 0.008
2	0.060 \pm 0.007
	0.050 \pm 0.007
	0.054 \pm 0.008
	0.063 \pm 0.007
3	1.59 \pm 0.04
	0.56 \pm 0.02
	0.94 \pm 0.03
	0.68 \pm 0.03 ^a
4	0.62 \pm 0.02
	0.56 \pm 0.02
	0.57 \pm 0.02
5	0.044 \pm 0.006
	0.077 \pm 0.008
	0.042 \pm 0.005
	0.055 \pm 0.010
	0.047 \pm 0.006
6	0.079 \pm 0.009
	0.058 \pm 0.008
	0.071 \pm 0.009
	0.29 \pm 0.01
7	0.051 \pm 0.007
	0.066 \pm 0.009
	0.056 \pm 0.006
	0.052 \pm 0.006
8	0.071 \pm 0.008
	0.22 \pm 0.02
	0.051 \pm 0.007
	0.059 \pm 0.006
9	0.35 \pm 0.02
	0.78 \pm 0.04
	1.73 \pm 0.04
	0.26 \pm 0.01

^aLeached according to Ch u^3 . Insoluble, 10%; acid soluble, 90%.

2. J. Mishima and L. C. Schwendiman, "The Amount and Characteristics of Plutonium Made Airborne under Thermal Stress," Symposium on Health Physics Aspects of Nuclear Facility Siting, Idaho Falls, Idaho, Nov. 3-6, 1970.
3. D. N. Kelkar and P. V. Joshi, *Health Phys.*, 19, 529 (1970).
4. E. B. Fowler, J. R. Buchholz, C. W. Christenson, W. H. Adams, E. R. Rodriguez, J. M. Celma, E. Iranzo, and C. A. Ramis, U. S. Atomic Energy Comm., Document LA-DC-9544 (1968).
5. A. W. Klement, Jr., Ed., "Radioactive Fallout from Nuclear Weapons Tests," U. S. Atomic Energy Comm. Symposium Series 5, 98-143 (Nov. 1965).

PLUTONIUM IN SURFACE SOIL IN THE HANFORD PLANT ENVIRONS

by

J. P. Corley, D. M. Robertson and F. P. Brauer
Battelle Memorial Institute
Pacific Northwest Laboratory
Richland, Washington

ABSTRACT

Surface soil sampling from February, 1970 through April, 1971 on and around the Atomic Energy Commission's Hanford Reservation is described. The sample sites selected were from less than 1 mile to as far as 30 miles from major plutonium-handling facilities, including sites around the perimeter of the AEC controlled land.

The top one-half inch of soil was sampled. Vegetative litter and rootmat were avoided as much as possible. Portions of the mixed soil samples were dried and analyzed for plutonium content, using acid leaching, solvent extraction, and alpha counting. Several locations were sampled in replicate. Certain samples were analyzed in duplicate. The plutonium results (all as dpm plutonium per g of dry soil) grouped by general location were: within restricted areas, from 0.05 to 1.4; outside restricted areas but within the reservation boundaries, < 0.01 to 0.28; and outside the plant boundary, from < 0.01 to 0.13.

Introduction

I must preface my talk with a cautionary remark. Although any conclusions that might be drawn from the limited data we have available so far can be at best tentative, we believe that recent data collected at the Hanford site, and the techniques used, might be of interest to this symposium.

Analyses for plutonium in air, water, and foodstuffs have been part of the routine surveillance program at Hanford. We have surveyed the ground and other surfaces for plutonium where there was possible deposition from stack emissions, waste spills, etc., using direct instrument measurements. Detectable plutonium deposition from the few such incidents has been confined to restricted areas. The surface contamination level that can be detected with our portable instruments is approximately $0.007 \mu\text{g Pu}/100 \text{ cm}^2$.

The desire to obtain additional information regarding any spread of plutonium beyond the restricted areas, as well as to distinguish between any plutonium in soil resulting from plant activities, and that resulting from

fallout led to a screening survey for plutonium in surface soils both on- and off-site in February, 1970.

The results to date and the procedures followed are discussed in this paper. Although some additional samples have been taken, the major part of my discussion will be on the initial survey. The limited amount of subsequent data has given results within the same range of plutonium concentrations.

Sampling Procedure

In order to minimize the variables associated with the sampling, an attempt was made to select uniform sampling sites. At Hanford, this means desert soils as free as possible from rocks and standing vegetation. Emphasis was placed on the sampling of undisturbed soils and only minimum amounts of rootmat or vegetative litter were accepted. Since the primary objective was to determine the current distribution of plutonium rather than to make a total environmental inventory, the sampling depth was kept to a practical minimum.

Initial sampling was done with a flat-bottomed scoop approximately 18 by 12 in. An attempt was made to take only the top ½ in. of soil. Subsequent sampling has been done with a closed-top sampler to minimize variation in sample depth. An ordinary cellulose tape container gives a neat, sharp-edged, reproducible cut in our desert soils, 9-cm in diam by 1.6-cm deep, provided no larger gravels are present. A trowel was used to make a clean cut across the bottom edge of the container and to retain the entire sample for transfer to a tared polystyrene sample jar. Repeated cuts within the selected sampling area give a total sample weight of 150 g or more. Samples of known depth can be taken by removing soil from the side of the implanted container just deep enough to expose its bottom edge, removing the sample, and repeating the procedure.

Plutonium analyses on the samples of February, 1970, were performed by two laboratories, Battelle-Northwest and U.S. Testing Company. The Battelle-Northwest Laboratory procedure used aliquots of 10 g (dry weight) of soil for plutonium analysis. Each aliquot was spiked with a nominal 1 dpm of ^{236}Pu and heated for 2 to 3 h at 750°C . The soil was then leached with both dilute and concentrated hydrochloric acid followed by concentrated nitric acid. The total acid contact time was 3 to 4 d. The leach solution (10M in HCl) was loaded on Dowex-1 anion exchange resin and the resin washed with 10M HCl. The plutonium was reduced and eluted with 0.1M ammonium iodide in 5M HCl. The plutonium-bearing effluent was converted to 8M HNO_3 and again loaded onto Dowex-1; the resin was then washed with 8M HNO_3 , and eluted with 1.2N HCl. A final purification was accomplished with a thenoyltrifluoroacetone (TTA) extraction. The plutonium-bearing organic phase was evaporated on a platinum disc, counted with a 150 mm² silicon surface-barrier detector for 8 to 10 d. Process-blank counting rates were less than one-tenth of the lowest sample counting rate. The detection level by this procedure is estimated to be 0.01 dpm per sample for a 10 d count or about 0.001 dpm/g $^{239+240}\text{Pu}$ of soil. Use of the silicon detector permitted distinction of ^{238}Pu from the $^{239+240}\text{Pu}$.

The ^{137}Cs content of the samples was measured by gamma-ray spectrometry and used to normalize the plutonium results for differences in the fallout content of the various samples. Several hundred g of sample were placed in a 5-in. diam by ¾-in. deep plastic container. The samples were counted for at least 1000 min each between a pair of 6-in. diam by 5-in. thick NaI(Tl) detectors operated in anticoincidence with a plastic phosphor annulus for Compton suppression and background reduction. A weighted least-squares method was used to calculate ^{137}Cs estimates from the spectral data.^{1,2,3} The calculations gave a precision estimate for the ^{137}Cs analyses of better than ± 5%.

For a few of the February, 1970 samples, and for all subsequent samples, a somewhat different plutonium

analytical procedure was used by the U.S. Testing Company.* Samples were weighed, oven-dried at 125°C for 24 h, and manually stirred to mix the sample and break up any clods. Five g of dried soil were used for hot leaching. One-hundred ml of 8N HNO_3 plus 2 drops of concentrated HF were applied under reflux. The resulting mixture was filtered and washed with hot 1N HNO_3 . After evaporating the leach solution to dryness and resolubilizing, a lanthanum fluoride coprecipitation was carried out. TTA extraction and electrolytic deposition were used to purify and mount the plutonium for counting. Counting was performed by exposing NTA film to the plated disc for approximately 1 wk. Alpha tracks in the film were counted and converted to dpm as total Pu. Yield by this procedure was nominally 65%, with an expected detection level of about 0.007 dpm/g of soil. The procedure described following the leach step is our standard bioassay procedure for plutonium.

Analytical Results

Figure 1 shows the Hanford reservation, the chemical separations areas, the reactor areas, and the

*U.S. Testing Company, Richland Branch - A Contractor to the Atomic Energy Commission.

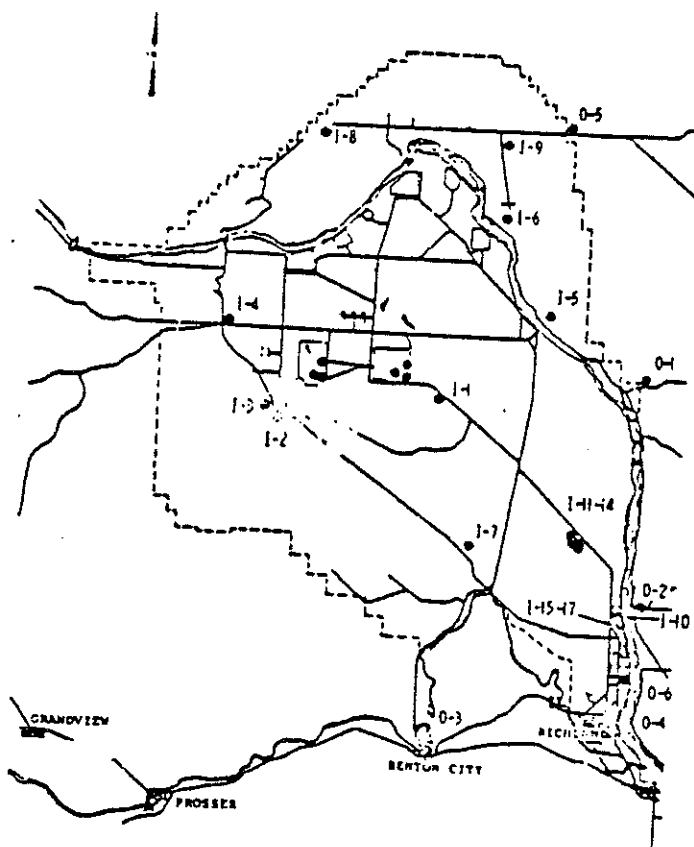

Fig. 1

laboratory areas, as well as nearby communities. Sampling sites are indicated.

The distance to the nearest chemical separations area has been listed in Fig. 2 for all samples outside these areas. Both areas have, in the past, included facilities for liquid processing of irradiated fuels, while the West area also has facilities for processing plutonium to metal and metal fabrications. Much smaller quantities of plutonium have been handled in the 300 (Laboratory) Area.

For the analytical data presented in Table I, U.S. Testing Company data are identified with an asterisk; the remainder are Battelle-Northwest data.

Bulk density measurements of the dried soil ranged from 1.35 to 1.65 g/ml, and an average value of 1.5 g/ml has been used to convert concentration by weight to surface deposition per unit area.

The right hand column is labeled *Multiple Analyses*. The entry *aliquot* in this column indicates analysis of more than one portion of one sample and *sample* indicates analysis of different samples taken at that one site.

The analytical results obtained on several samples taken from one sample site generally show about the same variation as replicate analyses on one sample. For the analyses performed by the Battelle Northwest

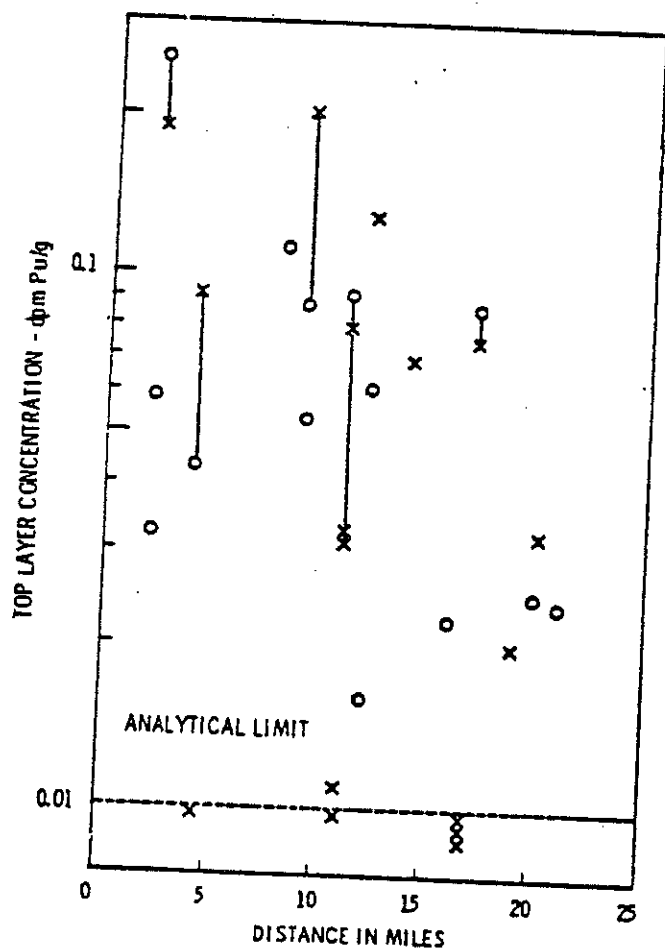

Fig. 2

TABLE I
PLUTONIUM IN SURFACE SOIL AT HANFORD - FEBRUARY-MARCH, 1991
(Laboratory A excess as indicated by *)

Distance from Separations Area, miles	Pu-(239+240) dpm/g	Pu-(239+240) nCi/m ²	Fraction Pu-238/Total Pu	Battelle Pu-(239+240) / (238+239)	Multiple Analyses
A. Inside Chemical Separations Areas					
	0.13 ± 0.01	1.17	0.23 ± 0.010	9.020	
	0.057 ± 0.004	0.49	+0.03	4.030	
	0.057 ± 0.002	0.49	+0.02	0.024	
	1.23 ± 0.06		0.079 ± 0.003	6.29	*Aliquots
	1.34 ± 0.16	13.9	0.033 ± 0.004	0.25	
	0.85 ± 0.04	7.3	0.026 ± 0.003	0.11	
	0.28 ± 0.01	2.41	0.042 ± 0.005	0.07	
B. Within Hanford Site Boundary					
2	0.27 ± 0.01		0.033 ± 0.010	0.079	*Aliquots
	0.34 ± 0.02	2.10	0.036 ± 0.007	0.026	
	0.10	1.63			
2	3.234 ± 0.023		+0.09	0.023	*Samples
	0.036 ± 0.004		+0.05	0.061	
	0.027 ± 0.002		+0.22	0.027	
	0.022 ± 0.002	0.48	0.018 ± 0.36	0.026	
2	3.064 ± 0.025		+0.08	0.025	*Samples
	0.053 ± 0.003	0.503	+0.18	0.021	
4	0.064 ± 0.003		+0.07	0.040	*Aliquots
	0.031 ± 0.005		+0.12	0.019	
	0.035 ± 0.002	0.37	0.05 ± 0.020	0.022	
	0.092	0.79			
8	0.112 ± 0.006	0.96	0.052 ± 0.008	0.019	
9	0.043 ± 0.003		0.089 ± 0.018	0.023	*Samples
	0.080 ± 0.004		0.054 ± 0.017	0.018	
	0.040 ± 0.002	0.46	0.06 ± 0.014	0.020	
9	3.081 ± 0.021		0.043 ± 0.010	0.017	*Aliquots
	0.095 ± 0.005	0.76	0.039 ± 0.012	0.019	
	0.275	1.76			
11	3.092 ± 0.004	0.79	0.041 ± 0.010	0.023	
	0.031	0.27			
12	0.016 ± 0.002	0.14	0.023 ± 0.010	0.023	
16	3.123 ± 0.002		+0.09	0.016	*Samples
	0.022 ± 0.002		+0.16	0.016	
C. Off-Site					
12	0.061 ± 0.005	0.52		0.017	
17	0.008 ± 0.001		0.029 ± 0.004	0.020	*Samples
	0.148 ± 0.007	0.76	0.027 ± 0.006	0.024	
	0.076	0.65			
20	0.025 ± 0.002	0.22	0.014 ± 0.027	0.025	*Aliquots
	0.005	0.04			
21	0.024 ± 0.003	0.21	+0.06	0.013	*Aliquots
	0.025	0.21			

Laboratory, the results are generally within statistically expected range. Values from the other laboratory compare less closely. The variations between sites and between replicate samples are believed due largely to non-uniform distribution, but other sources of inconsistency cannot be ruled out. However, the values obtained are generally in the expected range from other reported results for plutonium from fallout.

The primary intent of the work done was the identification of plutonium from plant releases within the restricted areas and to determine if this plutonium had migrated to areas outside the restricted areas. Figure 2 shows the ²³⁹⁺²⁴⁰Pu activity concentration as a function of distance from plutonium processing facilities. The variability is apparent, with no clear relationship. Figure 3 is a plot of ²³⁹⁺²⁴⁰Pu activity concentration versus that activity normalized to ¹³⁷Cs, attributed to fallout. As is readily seen, the samples marked W, those from the restricted area containing the plutonium-handling facilities, are distinct from all other samples. These values have a Pu/Cs activity ratio which can be attributed to plant releases. The remaining data, both on and off the reservation, have the same nominal Pu/Cs ratio, a ratio characteristic of regional surface fallout at the time of sampling.

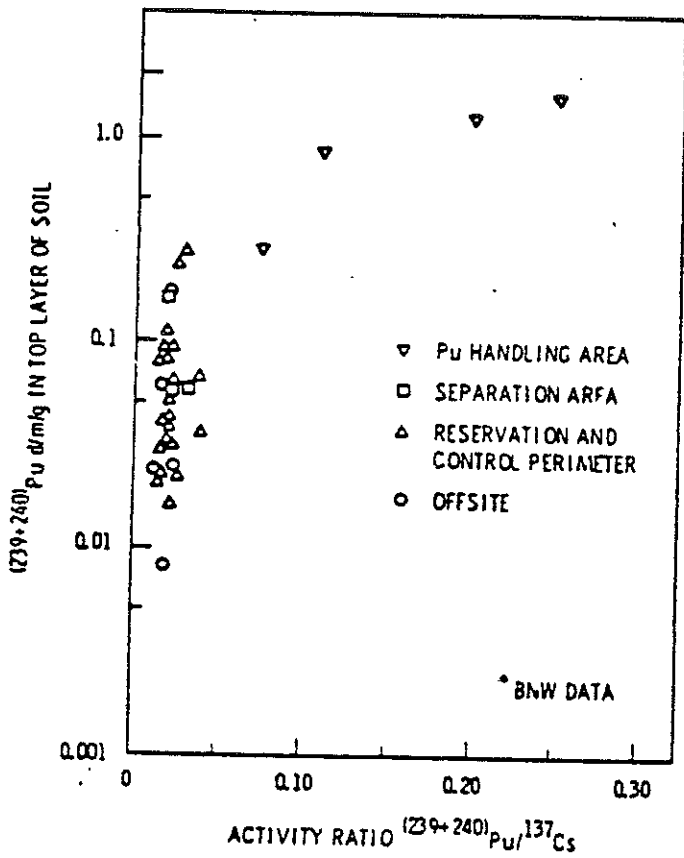

Fig. 3

Summary and Conclusions

During the operation of the Hanford plant, small, localized releases of plutonium have taken place. The samples from the restricted West area, confirm this fact and indicate that a different Pu/Cs activity ratio is to be expected from that due to fallout. The samples from both outside the restricted area but within the plant boundaries, and outside the plant boundaries, have the same Pu/Cs ratio, indicating that the plutonium found is due to fallout and not plant operation.

I have been impressed by the precision reported in other papers at this meeting, and hope to make use in the future of some of the things we have learned.

References

1. W. L. Nicholson, J. E. Schlosser, and F. P. Brauer, "The Quantitative Analysis of Sets of Multicomponent Time - Dependent Spectra from the Decay of Radionuclides," *Nucl. Instr. and Meth.*, 25 45-66, 1963.
2. F. P. Brauer and J. E. Schlosser, "Spectral Data Handling Systems," *Modern Trends in Activation Analysis*, J. R. DeVoe, ed., 2, 1102-1107, 1969.
3. J. F. Fager and J. H. Kaye, "Preliminary Processing of Multiplexed Two-Parameter Gamma-Spectrometer Data," *Decus Proceedings Spring 1970*, 45-51, 1970.
4. Environmental Evaluations Staff, J. P. Corley, Manager, *Evaluation of Radiological Conditions in the Vicinity of Hanford for 1969*. C. B. Wilson and T. H. Essig, eds., November 1970, BNWL-1505 Appendix.

MEASUREMENT OF PLUTONIUM IN SOIL AROUND THE NEVADA TEST SITE

by

Wayne Bliss and Leslie Dunn
Western Environmental Research Laboratory
Environmental Protection Agency
Las Vegas, Nevada

ABSTRACT

Experiments conducted at the Atomic Energy Commission's Nevada Test Site between 1951 and 1963, using plutonium in both critical and sub-critical configurations, have resulted in distribution of plutonium beyond the boundaries of the Test Site. The Southwestern Radiological Health Laboratory of the Environmental Protection Agency is conducting a survey to assess the distribution and concentration of plutonium in the off-site environment.

Special sampling methods were devised since desert soil is too coarse and dry for auger and *cookie cutter* sampling techniques. Soil sample analyses are performed by a dissolution, ion exchange, and electrodeposition procedure followed by alpha spectroscopy. Plutonium has been detected in four locations around the Nevada Test Site. These locations correspond to fall-out areas previously identified for the various test series. Plutonium concentrations in the top 3 cm of soil were 10 to 100 times greater than the concentration in soils from areas not subject to contamination by these series.

Nuclear experiments conducted by the U.S. Atomic Energy Commission at the Nevada Test Site between 1951 and 1963 using plutonium in both critical and sub-critical configurations have resulted in distribution of plutonium beyond the test-site boundaries. These experiments were generally of three types. There were accidental ventings of underground explosions which contributed little, if any, to off-site plutonium deposition. There were also atmospheric detonations of full-scale nuclear explosives, such as the Plumbbob series of 1957. A high percentage of the plutonium used in such devices would escape unfissioned.¹ These experiments may not have contributed largely to local off-site deposition. The third type, and probably the principal contributor to current plutonium in the close-in, off-NTS area, were the so-called one-point or safety detonations. These tests were to test the effects which would result should the high-explosive component of a device be accidentally detonated.

As part of its responsibility for radiation monitoring around the Nevada Test Site, the Southwestern Radiological Health Laboratory (SWRHL) has been conducting

a soil sampling program to determine off-site plutonium levels. The main objective of the study is to define the current plutonium distribution around the Nevada Test Site, determine if it is migrating by natural phenomena, and determine if man has been, or may be, subject to plutonium exposure. Should there be any health hazard, it will be shown by the study results. Concurrent with this off-site study, more detailed and complex studies are being conducted on the Nevada Test Site to evaluate soil to man routes and any related hazards. Studies of resuspension, air sampling, plant and animal sampling, and particle analysis, shall be done following this distribution survey. Procedures and results for the early phase of the off-site soil sampling study are presented in this paper.

The Atomic Energy Commission's Nevada Test Site (NTS) lies approximately sixty-five miles northwest of Las Vegas, Nevada in the Great Basin area. The soil on and around the Nevada Test Site is primarily of volcanic origin. The valleys are composed of gently to moderately sloping alluvial fans and terraces. The soil is of coarse texture with low organic content and low water-holding

characteristics. The mountains are steep to very steep and composed of sedimentary, metamorphic, and igneous stone.²

This soil survey was begun at twenty populated locations around the Nevada Test Site and two unpopulated locations (see Fig. 1). These locations are both inside and outside the fission product fallout patterns defined for the test series above. Baker, California and Kingman, Arizona were selected as background stations. Initial soil samples were collected from profiles to determine vertical disposition of plutonium. Two profile samples were collected in the vicinity of each location, usually three to five miles apart. Profiles of 23-cm deep and 200-cm square were sampled with layers divided at 1, 3, 7, and 15 cm.

Since desert soil is too dry and too coarse to use cookie cutter or auger sampling methods, the samples were collected by a pit technique. A pit was dug as deep as necessary to accommodate the maximum sampling depth plus some working room. One face of this hole was left vertical. From this face was trowelled or scooped the desired thickness and area layers. A fixed-size scoop works well. After the scoop is inserted, its mouth may be covered with a broad knife to fix the sampled area or volume. Also, it is convenient to slide a flat plate under the inserted scoop to prevent mixing any material which falls into the sampled area with the subsequent sample.

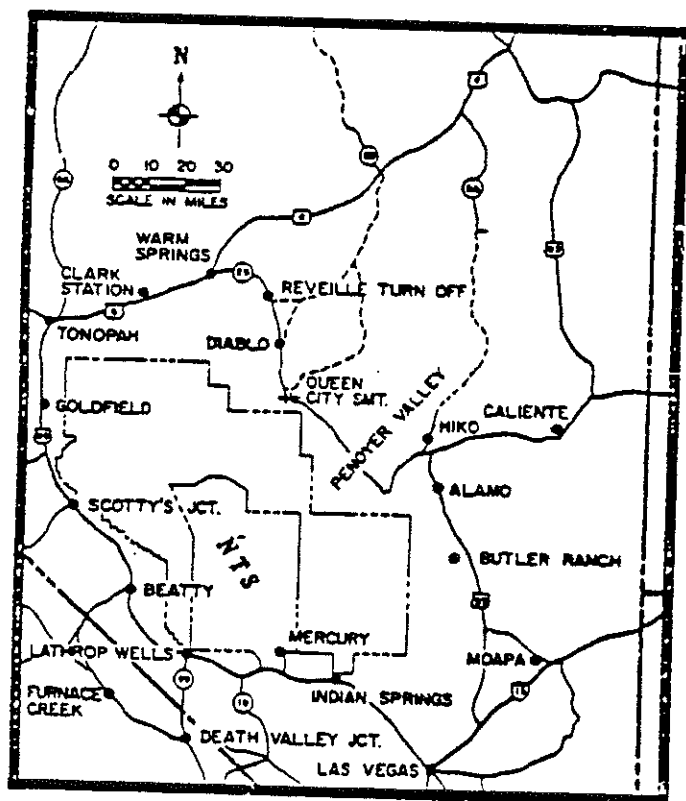

Fig. 1

After the layer is removed, surrounding material may be cleared away to prevent backfall which may hinder sampling the lower layers.

Area sampling is done with a scoop technique. Not less than ten scoops totalling more than 1 ft² are used to composite one sample. As above, the scoop is designed for a fixed sample depth and area. To date, this has been 5 cm by 100 cm². Based on the profile results, it appears that 5-cm deep will be sufficient for most cases.

All samples are prepared for analysis in a similar fashion. The sample is first screened and subdivided. There is general agreement that plutonium will reside in some fine fraction of the soil. There is not agreement of what fraction to eliminate. Some analysts discard the material more coarse than 200-mesh; some discard material more coarse than 25-mesh.³ The SWRHL procedure uses 10-mesh as a dividing point. The more coarse material is gently ground in a mortar to break up the clods and screened. The fine fraction is divided by a riffing apparatus to provide aliquots for analysis. An aliquot sufficiently small to be handled in a 100 cc bottle (approx. 100 g) is chosen for plutonium analysis and another aliquot of about 400 cc (about 500 g) is selected for gamma spectroscopy.

The small aliquot is dried at 110°C, ground and mixed. One-g aliquots are ignited at 700°C and dissolved in a Teflon beaker by digestion with nitric and hydrofluoric acids. Nitrate, fluoride, and silica are removed by evaporation to dryness followed by repeated evaporations in the presence of hydrochloric acid. Plutonium is absorbed from a 9M hydrochloric acid solution of the residue on a column of AG 1 x 2 anionic exchange resin. Co-adsorbed iron is removed from the resin with 7.2M nitric acid after which the plutonium is reductively eluted from the resin with 1.2M hydrochloric acid containing 0.6% hydrogen peroxide. The separated plutonium is electrodeposited from 1M ammonium sulfate media onto stainless steel planchets. The activity of the plutonium is determined by alpha spectroscopy using ²³⁶Pu as an internal reference standard.^{4,5}

The 400 cc aliquot is counted 40 min on a 4 x 4 in. NaI(Tl) crystal coupled to a 400 channel pulse-height analyzer. The taped spectrum is analyzed by a matrix solution for ¹⁸¹W, ²²⁶Ra, ²³²Th, ¹³⁷Cs, ⁴⁰K, ⁵⁴Mn, ¹⁰⁶Ru and ⁹⁵Zr.

Gamma-scan results show nothing extraordinary for the locations sampled for this survey.

Typical results which have been found for plutonium are shown in Table I. The values shown are computed from the concentration in pCi/g at the two-sigma confidence level. These results are preliminary and subject to minor modifications as procedures are refined or repeated analyses are performed.

Plutonium was detected in only the top 3 cm in most cases and the profile pairs agreed to within a factor of three in most cases. Three area samples were collected at Lathrop Wells to evaluate the variance within a group of cores and between locations, but unfortunately they were collected at one of the disagreeing cases. Another

TABLE I
MEASUREMENT OF ²³⁹Pu IN SOILS AROUND
THE NEVADA TEST SITE

Location (see Figure 1)	Pu (mCi/km ²)	
Penoyer Valley	1 mi E of Co Line	130 ± 6.0
	6 mi E of Co Line	6.7 ± 1.5
Queen City Summit	profile at summit	19 ± 1.0
	(1000 cm ² surface scraping)	22 ± 1.9
Highway 25/Reveille Turnoff		5.7 ± 0.71
Lathrop Wells	2 mi E	6.1 ± 0.94
	2 mi W	0.3 ± 0.2
	2 mi E surface	17 ± 3.2
	2 mi E surface	2.6 ± 1.3
	2 mi W surface	0
Alamo	4.2 mi N	2.1 ± 0.64
	3.4 mi S	1.9 ± 0.45
Beatty	2.4 mi N	3.8 ± 0.88
	6.6 mi S	3.0 ± 0.84
Tonopah	1.5 mi S	0.5 ± 0.2
	3.9 mi NW	1.1 ± 0.52
Warm Springs	2.6 mi E	1.3 ± 1.0
	4.5 mi W	3.0 ± 1.1
Moapa	4 mi NW	1.9 ± 0.92
	7 mi NW	0.6 ± 0.4
Diablo	2.4 mi N	7.8 ± 1.8
	2 mi S	8.2 ± 1.3
Goldfield	3.4 mi S	4.3 ± 0.79
	3.8 mi N	2.5 ± 0.58
Butler Ranch	1.9 mi S	1.4 ± 0.89
	2.3 mi N	22 ± 2.4
Caliente	4 mi N	1.1 ± 0.64
	4.2 mi S	0.8 ± 0.3
Indian Springs	1.5 mi E	0.9 ± 0.5
	3.7 mi W	1.5 ± 0.39
Furnace Creek, California	1.3 mi S of Inn	0.4 ± 0.1
	0.6 mi N of Ranch	0.6 ± 0.3
Scotty's Jct.	2.3 mi S	4.0 ± 1.3
	2.1 mi N	1.2 ± 0.39

Location (see Figure 1)		^{239}Pu (mCi/km ²)
Clark Station	1 mi W	1.9 ± 0.61
	2 mi E	14 ± 2.6*
Hiko	3.6 mi N	1.6 ± 0.54
	1.5 mi S	0.8 ± 0.4
Kingman, Arizona	0.6 mi E	0.7 ± 0.4
	1.6 mi W	1.0 ± 0.5
Baker, California	1 mi N of Airport	0
	6 mi N of Airport	0.2 ± 0.2
Death Valley Junction, California	1.4 mi S	4.0 ± 0.63
	2.1 mi N	0.5 ± 0.2
Las Vegas	3 mi W	1.8 ± 0.70
	5 mi SW	0.5 ± 0.2

*This result is under question. Another sample will be analyzed.

sample was collected from a cultivated field in which plutonium was found, however no plutonium was found in the barley growing there. No data correlations have yet been made between these data and data generated during the test periods when plutonium was known to have been released. It is noteworthy that Lathrop Wells was in or near the fallout pattern of many of the Hardtack, Phase II experiments and Butler Ranch lay in the fallout pattern of the Smoky Event of Operation Plumbbob. No analyses capable of defining specific origins of the plutonium have yet been attempted. The locations sampled in this survey which showed plutonium do coincide with fission product fallout patterns defined for the above mentioned test series.

This preliminary information shows there is detectable ^{239}Pu in the areas around the Nevada Test Site and point out four general areas for further study. These areas are Lathrop Wells, Goldfield to Scotty's Junction, Penoyer Valley to Reveille Turnoff, and Butler Ranch. The highest deposition of ^{239}Pu is northeast of the Nevada Test Site with the second highest deposition being southwest as defined by this survey. Values range from 130 mCi/km² to background. Sampling will now be expanded in these four areas to define distribution patterns as they now exist.

References

1. Samuel Glasstone ed., *The Effects of Nuclear Weapons*, U.S. Atomic Energy Commission, (1962, rev. 1964).
2. Verr Leavitt, Soil Scientist, Radiological Research Program, Southwestern Radiological Health Laboratory, Las Vegas, Nevada.
3. Bortoli, Caglione, *Natural and Fallout Radioactivity in the Soil*, Health Phys., Vol. 17, pp. 701-710, Pergamon Press, New York, (1969).
4. N. A. Talvite, *Determination of Plutonium in Environmental and Biological Samples by Ion Exchange* (as revised), Southwestern Radiological Health Laboratory, Las Vegas, Nevada.
5. N. A. Talvite, "Electrodeposition of Plutonium and Thorium from Ammonium Sulfate Medium," ITR-19, Southwestern Radiological Health Laboratory, Las Vegas, Nevada (1969).

CONCENTRATIONS OF PLUTONIUM, COBALT, AND SILVER RADIONUCLIDES IN SELECTED PACIFIC SEAWEEDS

by

K. M. Wong, V. F. Hodge, and T. R. Folsom
Scripps Institution of Oceanography
University of California, San Diego
La Jolla, California

ABSTRACT

Recent studies of marine organisms from the North Atlantic Ocean show that exceptionally high concentrations of ^{239}Pu have been found in seaweeds. The enrichment of other radionuclides also have been observed in certain species of sea plants in the Hudson River and in the Pacific. The high uptake of radionuclides and the relative ease of sampling suggest that seaweeds may be ideal for monitoring certain radio-activities in the marine environment.

For this reason, we have initiated a survey of the concentrations of plutonium, radiocobalt and radiosilver in several species of seaweeds collected along the coastal water of Southern California. Preliminary findings concerning the distribution of ^{239}Pu and some other radionuclides are reported.

Introduction

Recent measurements of marine samples have demonstrated that exceptionally high concentrations of plutonium are to be found in seaweeds.¹⁻⁴ It is already evident that the high concentrations in seaweeds make them sensitive indicators of changes in plutonium in the environment, and that relatively small samples of seaweeds that are, in many cases, easy to collect and can easily be analyzed with precision. Nevertheless, the plutonium concentrations in only a few of the various known species of algae and marine grasses have yet been measured and compared with concentrations in their environmental sea water. For instance, relatively few measurements have been made concerning plutonium in the red algae and in the marine grasses living in relatively uncontaminated oceanic environment.

It is the purpose of this paper to report findings of a preliminary survey of plutonium concentrations in a few selected organisms collected recently along the coast of Southern California. The samples include several species for which no previous studies have been made. Also, some identical species were collected in several different marine environments for comparison of their plutonium contents. Wherever possible, correlations have been made

between plutonium concentrations found in the species and the concentrations of certain other nuclides that have been found useful in the past for monitoring the progress of radioactive contaminations from fallout and from coastal (and shipboard) reactors. These latter include ^{58}Co , ^{60}Co , ^{110m}Ag , and a few other gamma-emitting nuclides.

It is apparent that many of the seaweeds may be useful as monitors. They are abundant; several species are widely distributed; they usually may be collected near sources of pollution, reactor discharge pipes, and sewage out-falls. They integrate effects of environmental contaminations, depending upon their life spans, for periods of less than one year to more than 24 years.⁵

These preliminary results tend to emphasize that seaweeds might be still more useful if more were known as to the rates by which trace elements were accumulated by the separate genera and species, and also if more were known about their responses in different environments.

Methods

Twelve species of seaweed were collected from five stations along the coast of Southern California as shown

in Fig. 1. Certain samples of the same species were also collected from different stations at different times to check for variation of plutonium concentration as a function of geographic location and collection time. All these samples were collected between December, 1970 and July, 1971.

The detailed analytical procedure has been fully described elsewhere.⁶ The collected samples were separated and identified by genera, then washed in sea water to remove sand and loose foreign materials. The wet samples were weighed, dried at 100°C, and ashed to constant weight at 450 to 475°C in a muffle furnace. The ashed samples were dissolved in HNO₃-HCl and ²³⁶Pu tracer was added to serve as radiochemical yield monitor. The plutonium was separated and purified by anion exchange column, electroplated onto a stainless steel disk, and determined by alpha spectrometry.

Results and Discussion

Table I summarizes our data on samples collected from the coastal water of Southern California. The

concentration of ²³⁹Pu and four gamma emitters are shown.

The samples are grouped separately into red algae, brown algae, green algae, and two kinds of marine grasses so that their behavior can be discussed separately.

It appears, from Table I, that there is a wide variation in ²³⁹Pu concentration among the different species of seaweeds. Also, variations by factors from 3 to 5 have been observed even when the same species were collected at different times or locations.

It may be noticed first that the highest concentration of ⁹⁵Zr/⁹⁵Nb are associated with all of the samples that were collected during the period of June 21 to July 4, 1971. This suggests that a new source of fallout has been encountered this year. The concentration of ⁵⁸Co, ⁶⁰Co and ^{110m}Ag in the samples, however, do not correlate with the same increase in ²³⁹Pu or ⁹⁵Zr/⁹⁵Nb activities. Since ⁵⁸Co, ⁶⁰Co and ^{110m}Ag are believed to have been released from the San Onofre Nuclear Power Reactor (collection site B in Fig. 1), this negative correlation of ⁵⁸Co in these samples suggests that the new activity did not come from the San Onofre effluents.

Further examination of the samples containing the

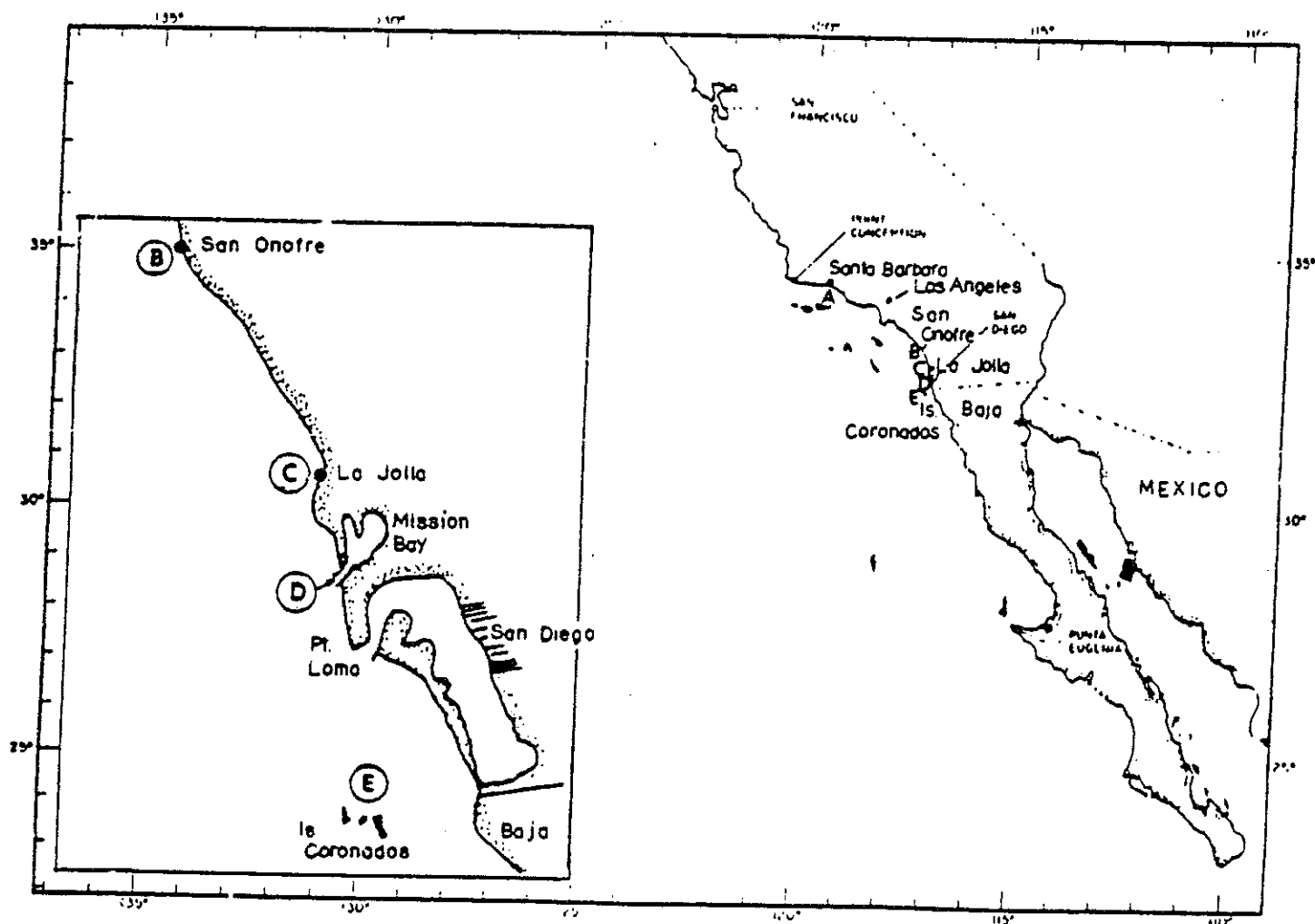

Fig. 1

TABLE I
RADIONUCLIDE CONCENTRATIONS IN PACIFIC SEAWEEDS

Sample	Collection		dpm/kg wet sample ^a				
	Date	Site	²³⁹ Pu	⁵⁸ Co	⁶⁰ Co	^{110m} Ag	⁹⁵ Zr ⁹⁵ Nb
Red Algae							
Gelidium sp.	12-12-70	B	0.58 ± 0.07	98	10	12	< 4
Gelidium sp.	12-12-70	C	0.42 ± 0.04	< 2	3	< 2	< 4
Gelidium sp.	7- 1-71	E	2.20 ± 0.15	< 2	9	< 2	930
Amphiroa sp.	6-30-71	D	2.10 ± 0.20	-	-	-	780
Corallina sp.	3-30-71	B	1.48 ± 0.15	950	48	41	< 4
Brown Algae							
Macrocystis sp.	Apr. 64	C	0.71 ± 0.06 ^c	-	-	-	-
Macrocystis sp.	6-30-71	D	0.71 ± 0.05	< 2	< 2	< 1	540
Macrocystis sp.	7- 4-71	A	0.67 ± 0.10	-	-	-	-
Eisenia sp.	Apr. 64	C	1.00 ± 0.05 ^c	-	-	-	-
Eisenia sp.	7- 1-71	E	2.85 ± 0.25	-	-	-	-
Egregia sp.	3-10-71	B	0.44 ± 0.03	49	< 2	< 1	< 4
Egregia sp.	7- 1-71	E	1.55 ± 0.09	< 2	< 2	< 1	290
Zonaira sp.	3-10-71	B	1.65 ± 0.19	-	46	-	-
Zonaria sp.	7- 1-71	E	5.50 ± 0.30	< 2	4	< 1	92
Sargassum sp.	6-30-71	D	0.52 ± 0.05	-	-	-	308
Sargassum sp.	7- 4-71	A	0.72 ± 0.25	-	-	-	-
Dictyopteris sp.	6-30-71	D	3.70 ± 0.20	< 2	< 2	< 2	910
Green Algae							
Ulva sp.	6-30-71	D	1.20 ± 0.40	< 2	6	6	129
Surf Grass							
Phyllospadix sp.	3-19-71	B	0.61 ± 0.03	960	61	93	< 4
Phyllospadix sp.	6-21-71	C	0.90 ± 0.12	< 2	18	< 2	411
Zostera sp.	6-30-71	D	0.68 ± 0.08	-	-	-	200

^aThe reported error for ²³⁹Pu is one standard deviation of the counting data. The counting error for other radionuclides is equal to or less than 10%. Activity below detection limit is indicated by less than value.

^bSee Figure 1 for sampling locations.

^cData from Pillai et al., 1964¹

highest ²³⁹Pu concentration clearly shows that the greatest increase in ⁹⁵Zr activity was related to the sampling location near Coronado Island as shown in Table II. This is consistent with geographic variations found in earlier studies of fallout carried out in surface seawater west of California in 1964-1965.⁷ For example, Table III shows that the ²³⁹Pu concentration in seawater increased by a factor of 3 between samples collected from the Scripps Pier and those collected 10 miles from the coast. Since Coronado Island is about 8 miles from the coast, the 3 to 5 fold increase of ²³⁹Pu concentration in the seaweeds

collected there corresponds with the expected higher plutonium concentration in the seawater at this distance. It appears that for short periods after new global fallout occurs, there is an upward gradient of fallout concentrations in the surface seawater as one goes westward from the coast.

One ²³⁹Pu measurement of sea water from the Scripps Pier was made in June 1971. A concentration of 0.16 ± 0.04 dpm/100 liters was found. This is nearly a factor of 2 higher than the value found in 1964. This is also in agreement with the higher ²³⁹Pu concentration

TABLE II

VARIATION OF ^{239}Pu CONCENTRATION IN SEAWEED WITH SAMPLING LOCATIONS^a

Sample	Collection Date	^{239}Pu dpm/kg wet at sampling location				
		Santa Barbara A	San Onofre B	La Jolla C	San Diego D	Coronado Islands E
Gelidium sp. Gelidium sp. Gelidium sp.	12-12-70 12-29-70 7- 1-71		0.58 ± 0.07	0.42 ± 0.04		2.20 ± 0.15
Macrocystis sp. Macrocystis sp. Macrocystis sp.	Apr. 1964 ^b 6-30-71 7- 4-71	0.67 ± 0.10		0.71 ± 0.06	0.71 ± 0.05	
Eisenia sp. Eisenia sp.	Apr. 1964 ^b 7- 1-71			1.00 ± 0.05		2.85 ± 0.25
Egrecia sp. Egrecia sp.	3-10-71 7- 1-71		0.44 ± 0.03			1.55 ± 0.09
Zonaria sp. Zonaria sp.	3-10-71 7- 1-71		1.65 ± 0.19			5.50 ± 0.30
Sargassum sp. Sargassum sp.	6-30-71 7- 4-71	0.72 ± 0.25			0.52 ± 0.05	
Phyllospadix sp. Phyllospadix sp.	3-19-71 6-21-71		0.61 ± 0.03	0.90 ± 0.12		

^aDate retabulated from Table I.^bData from Pillai et al., 1964.

TABLE III

VARIATION OF ^{239}Pu , ^{90}Sr and ^{137}Cs IN SURFACE SEA WATER WEST OF CALIFORNIA 1964
(Data from Folsom et al., 1966)⁷

Station	Miles From Coast	pCi/100 liters		
		^{239}Pu	^{90}Sr	^{137}Cs
Scripps Pier				
32°40'N 116°30'W	(0.2)	0.04	-	12-46
35°12'N 120°57'W	10	0.11	9.7	16
34°16'N 120°03'W	30	0.11	5.0	9
33°49'N 121°50'W	100	0.14	19	27
33°50'N 126°35'W	300	0.15	37	59
33°00'N 132°30'W	700	0.30	57	66
32°30'N 133°00'W	720	0.26	-	-
30°N 140°W	1,100	0.30	37	48

observed in the seaweed from Coronado Island, if, as we believe, the plutonium concentration in the sea water still increases seawardly as it did in 1964. Using this new value of ^{239}Pu concentration for the coastal water, the concentration factor for the Southern California seaweeds range from 260 to 3500. These values fall within the data obtained by Pillai¹ and Noshkin.³

It is interesting to note that the highest concentration of ^{239}Pu ever found was in the North Atlantic *Sargassum* as shown in Table IV. On the other hand, a Pacific species of *Sargassum* was found to be one of the lowest concentrators observed in the present study. It will

be noted in Table I that another brown algae, *Zonaria*, was the highest concentrator found in this study but high concentrations were found in red and green algae and also in the two marine grasses. This example further illustrates how hard it is to generalize about the behavior of plutonium in the marine environment.

Conclusion and Future Work

The results obtained so far from this study pose more questions than answers concerning the interaction

TABLE IV

PLUTONIUM CONCENTRATION IN ATLANTIC MARINE ORGANISMS
(Condensed from data of Noshkin et al., 1971)³

Sample	Organ	^{239}Pu range, dpm/100 kg wet
Blue Mussel (<i>Mytilus edulis</i>)	body	36-97
Blue Mussel (<i>Mytilus edulis</i>)	shell	89-98
Oyster (<i>Ostrea virginica</i>)	body	19-31
Scallop (<i>Pecten irradians</i>)	Adductor muscle	2-7
Scallop (<i>Pecten irradians</i>)	body	78-131
Scallop (<i>Pecten irradians</i>)	shell	115
Starfish (<i>Asterias forbesi</i>)	body	167-220
Kelp		20
Staghorn (<i>Codium fragile</i>)		39
Chondrus crispus		76
Fucus vesiculosus		139
Ascophyllum nodosum		126-301
Sargasso Weed (<i>Sargassum</i> sp.)		124-18, 500

of the environmental plutonium and seaweeds. As indicated earlier, this is only a preliminary study by which we hoped to raise useful questions.

We may conclude then, that all species of seaweeds concentrate plutonium and that seaweeds may be a sensitive indicator for the detection of variations of plutonium concentration in the marine environment; also, further work should be done to correlate plutonium concentration between sea water and algae, and that a more comprehensive survey of the marine environment is needed. By comparing samples collected near the nuclear plant with samples of the same species on other coastal collection sites no evidence of anomalous ^{239}Pu was found near the plant, and definite evidence was found that ^{58}Co , ^{60}Co and ^{110m}Ag had been coming from the plant. By comparing different species collected near the nuclear plant, the red algae, *Gelidium* and *Corallina*, and a surf grass, *Phyllospadix*, accumulate higher concentrations of cobalt and silver radionuclides than did the brown algae. (It is interesting to note that one species of sea hare, *Aplysia californica*, that is believed to prefer red algae as food also shows higher concentrations of ^{58}Co , ^{60}Co and ^{110m}Ag . Typical concentrations were: 2200, 180, 260 dpm/kg wet sample respectively.)

Besides the accumulation of more data from analysis, we believe certain controlled experiments should be set up to study the rate and mechanisms of plutonium uptake by sea plants. It appears that more experiments similar to those done by Ward (1966)⁸ are necessary to establish quantitative relationships. We hope to make future contributions in this area.

Acknowledgment

We are most grateful for the valuable help given by James R. Stewart of Scripps for the collection and identification of many of the samples.

This work was supported by the U.S. Atomic Energy Commission, contract No. AT(04-3)-34, P. A. 71-15, and the U.S. Office of Naval Research, contract No. USN N00014-69-A-0200-6011.

References

1. K. C. Pillai, R. C. Smith, and T. R. Folsom, "Plutonium in the Marine Environment." *Nature* 203: 568-571, 1964.
2. K. M. Wong, J. C. Burke, and V. T. Bowen, "Plutonium Concentration in Organisms of the Atlantic Ocean," Fifth Annual Health Physics Society Mid-Year Topical Symposium, Idaho Falls, Idaho, November 1970.
3. V. E. Noshkin, V. T. Bowen, K. M. Wong, and J. C. Burke, "Plutonium in North Atlantic Ocean Organisms; Ecological Relationships," Third National Symposium on Radioecology, Oak Ridge, Tenn., May 1971.
4. A. Aarkrog, "Radioecological Investigation of Plutonium in an Arctic Marine Environment," *Health Phys.*, in press.
5. Y. E. Dawson, *Marine Botany*, Holt, Rinehart and Winston, Inc., N.Y., p. 73, 1966.
6. K. M. Wong, V. E. Noshkin, L. Surprenant, and V. T. Bowen, "Plutonium in Some Organisms and Sediments," U.S. Atomic Energy Comm. Rep. HASL-227: 1-25-1-33, 1970.
7. T. R. Folsom, K. C. Pillai, and T. M. Beasley, "Studies of Background Radioactivity Levels in the Marine Environment near Southern California," SIO Ref. No. 67-7-A, B,C, 1966.
8. E. E. Ward, "Uptake of Plutonium by the Lobster, *Homarus vulgaris*," *Nature* 209: 625-626, 1966.

RESUSPENSION OF PLUTONIUM-239 IN THE VICINITY OF ROCKY FLATS

by

H. L. Volchok
Health and Safety Laboratory
U.S. Atomic Energy Commission
New York, N.Y.

ABSTRACT

Continuous, high-volume airborne particulate sampling has been maintained for over a year, close to, and downwind from, the Rocky Flats plant. The sampler is in the vicinity of the highest ground concentrations of ^{239}Pu as determined in a 1970 inventory. The concentrations have averaged about 2 fCi/m^3 of air sampled, 10 to 100 times higher than the expected levels from fallout. In addition a qualitative correlation is demonstrated between wind velocity and ^{239}Pu concentration in the air. The results to date suggest resuspension factors of between 10^{-7} and 10^{-9} depending upon the assumption taken, for the depth of soil re-entrainment.

Introduction

Following the May 11, 1969 fire at the Rocky Flats plutonium processing plant, and the publicity generated by Dr. Martell's demonstration of plutonium in the soil off the plant site,¹ the Health and Safety Laboratory (HASL) undertook a program to study the distribution and inventory of ^{239}Pu in the area. This study was completed and published in August 1970.² In summary, it was found that the most likely source of the offsite plutonium in the environment was the barrels of contaminated oil which had been stored on the southeast corner of the plant property, and which were known to have leaked. The pattern of contamination on the ground was generally compatible with the average wind vectors in that region. The upper limit of the inventory of offsite ^{239}Pu attributable to contamination from the plant was found to be 5.8 curies. Figure 1, from the report by Krey and Hardy² is a contour representation of the ^{239}Pu distribution in the Rocky Flats area. The contours are lines of equal ^{239}Pu deposit in units of mCi/km^2 . It seems clear from Fig. 1, that the highest levels off the actual plant property are predominantly to the east and southeast, with the *hot spot* as defined by the contours, just adjacent to the area where the leaking drums had been stored.

Since the available evidence suggested that this offsite plutonium contamination was not a result of the fire, and could be generally correlated with the average wind patterns, it seems reasonable to assume that resuspension and transportation by the wind was responsible for this ground deposit. Hence, in mid-1970 we set out to obtain data on resuspension of plutonium in the Rocky Flats area.

Sampling and Analysis

We started with a single sampler placed as close as possible to the area which we believe to be the source. This is the so called Pad, where the barrels had been stored. The sampler is a standard HASL surface-air program, Roots Connersville blower. Using 8-in.-diam Microsorban filter paper, we routinely sample continuously for a week at an average flow rate of about $1 \text{ m}^3/\text{min}$. Figure 2 shows the sampler in a typical louvered housing on the HASL roof. At first the filters were composited into monthly groups for analysis, then, starting in the late summer of 1970, weekly samples were analyzed. All of the samples have been analyzed for both $^{239/240}\text{Pu}$ and ^{238}Pu , under contract with Traylor Division West, of Richmond California.

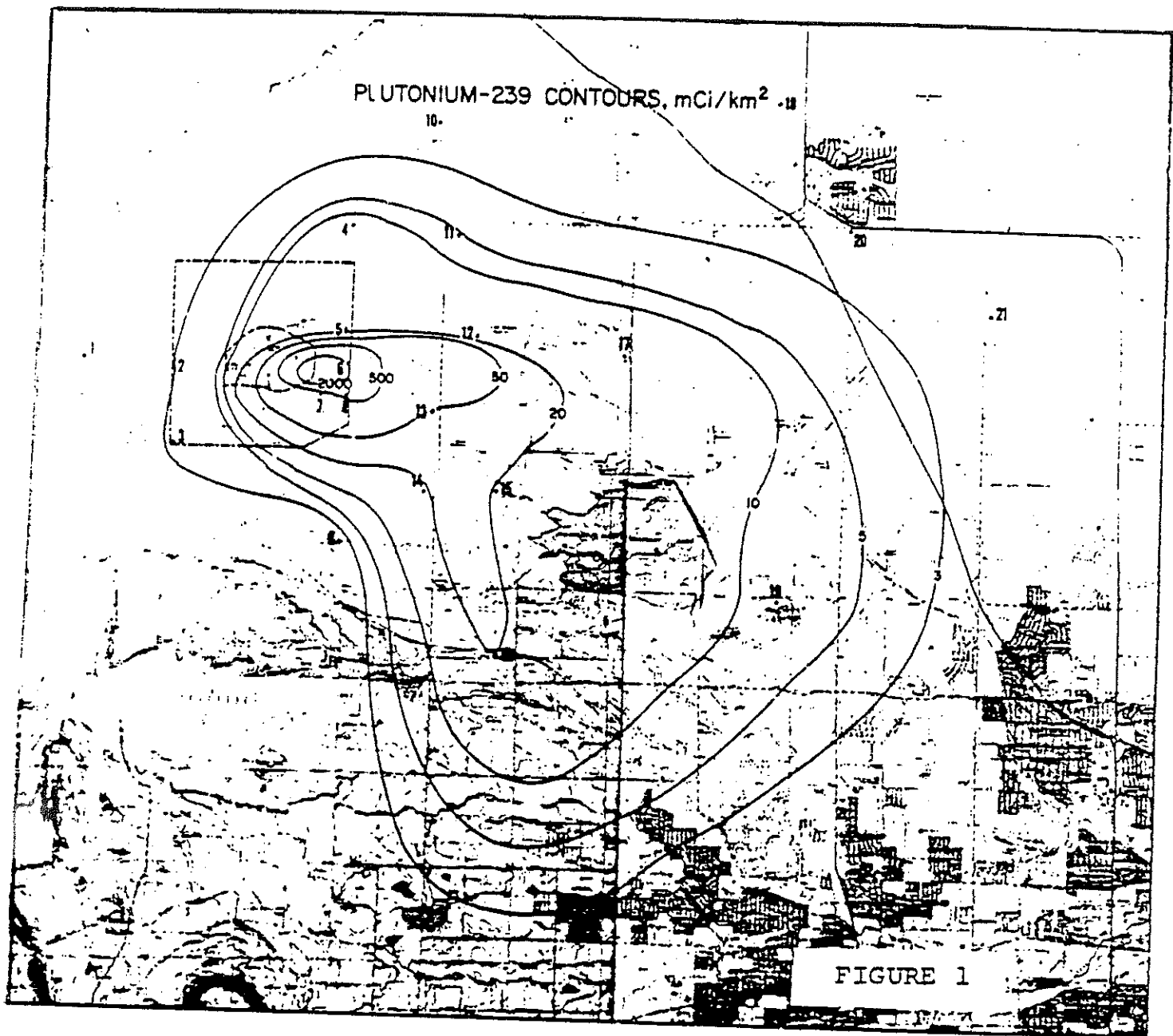

Fig. 1

Results and Discussion

Figure 3 illustrates all of the weekly data on ^{239}Pu concentrations in the air near Rocky Flats, as a function of time. The concentrations vary over more than a factor of ten, in the weekly samples, with a low of about 0.3 and a high of over 6 fCi/m³. A smoothed version of the data is obtained by averaging over each month, as shown by the dashed curve in Fig. 3. Here, there appears to be a downward trend through the summer, increasing as the samples get into fall and winter. This is of course qualitatively correlatable with wind intensities at Rocky Flats, and more will be said about this in a later section.

In Fig. 4, the monthly Rocky Flats air concentrations of ^{239}Pu are compared with similar data from other

sites in mid-latitudes of the Northern Hemisphere. Clearly the available results from Denver,³ New York City,⁴ and Ispra, Italy⁵ are similar. All three exhibit the expected seasonal variation of worldwide fallout, coming down from the spring-summer peak, to a winter low. The highest value at any of these three sites, in this period, was about .13 fCi/m³. The Rocky Flats results are quite obviously greater by more than a factor of ten, and as mentioned, indicate an almost opposite seasonal trend. The rather obvious conclusion from these graphs, is that the air near the Rocky Flats plant is definitely contaminated, and that the concentrations of plutonium at this site are a factor of ten or more higher than one would expect from worldwide fallout.

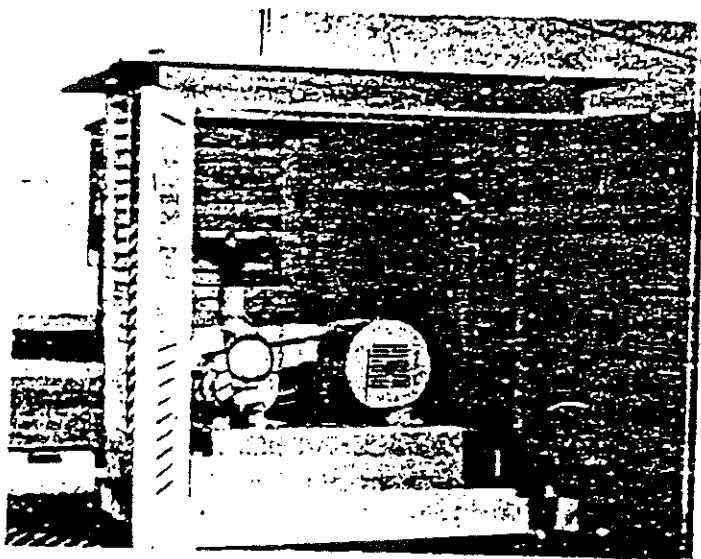

Fig. 2

Note that on the scale of fCi/m^3 of air, as shown on the graph of Fig. 4, the maximum permissible concentration (mpc) would be 60 units. This is the recommended level soluble plutonium, with bone as the critical organ, for nonoccupational exposure. So, on the average, this air at the edge of and downwind of, the contaminated area, is running between about 1 and 10% of the mpc.

Another method of showing the probable source of

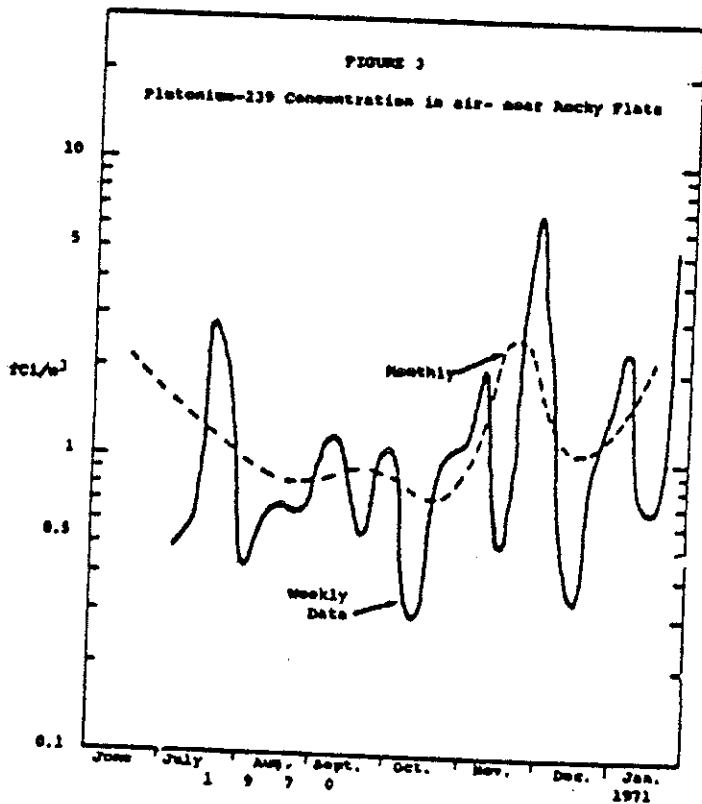

Fig. 3

the plutonium in the air near Rocky Flats is by use of the ratio $^{238}Pu/^{239}Pu$. As Dr. Harley pointed out in his presentation, there was a characteristic 238/239 ratio in the atmosphere from weapons tests prior to 1965; this was about 0.03, which is also the approximate ratio of weapons-grade plutonium. However, when the SNAP-9A power source burned up in the atmosphere, in 1964, enough additional ^{238}Pu was added to materially increase the ratio in surface air from 1966 on. The ratios in the Northern Hemisphere were summarized in Dr. Harley's Table IV showing a peak of about 0.5 in 1967. Table I lists the most recent data available from our surface air sites, Denver³ and Ispra,⁵ for comparison with the results on Rocky Flats samples. It seems very clear, from these values, that most of the plutonium in the air at Rocky Flats has about one third of the ratio of weapons-grade plutonium found in worldwide fallout. So, again the evidence strongly suggests that for the most part, plutonium in surface air near the plant, is contamination, that the source is the pad area, just west of our sampler. Additionally, the surface air in Denver appears to be uncontaminated by plutonium from Rocky Flats, at least to the degree of the sensitivity of this ratio.

Perhaps the best evidence that resuspension is playing a major part in the elevated plutonium levels in the surface air near Rocky Flats, is the relationship of these data to the winds. We have tried to correlate the concentration results with the available wind data obtained at Rocky Flats, in numerous ways. The problem in this sort of exercise, is that the shortest period of our

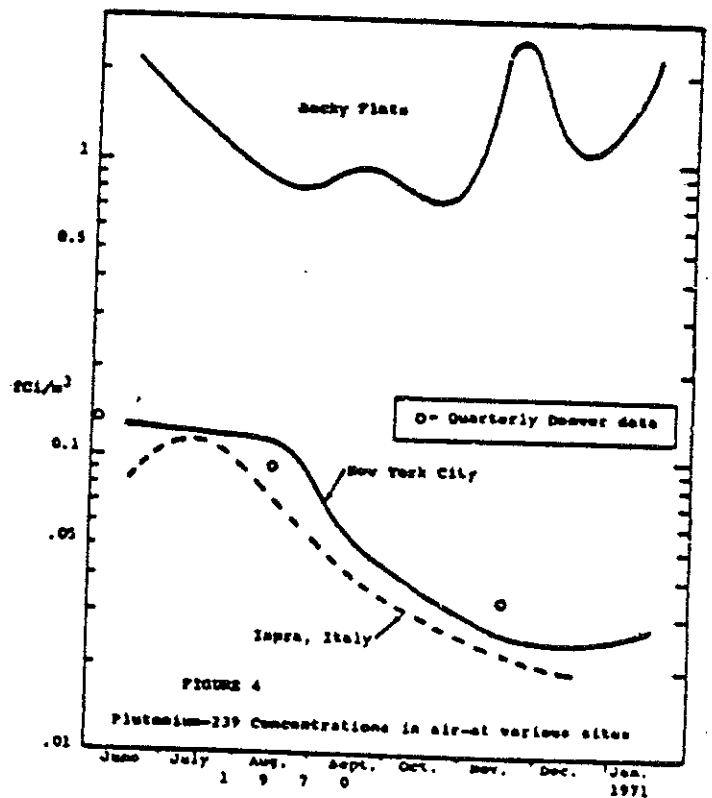

Fig. 4

TABLE I

²³⁸Pu/²³⁹Pu IN SURFACE AIR

(Mean values for the last half of 1970)

Moosonee, Ontario	0.08
New York City	0.11
Sterling, Virginia	0.10
Miami, Florida	0.08
San Juan, Puerto Rico	0.08
Denver, Colorado	0.09
Ispra, Italy	0.08
Rocky Flats, Colorado	0.03

sampling is one week, hence we have to do a lot of averaging of the wind data, and this may tend to obliterate or mask any correlation. We have tried correlating the weekly plutonium concentrations with such things as mean wind speed, peak gusts, mean weekly gusts, number of hours in the sampling period that the wind exceeded various speeds, etc. Qualitatively, most of these wind parameters indicate some correlation with the plutonium in the air. For example, Fig. 5 is a plot of concentration data vs. mean wind speed, for the one week sampling periods. In this plot we have differentiated between samples collected in the summer (open circles) and autumn (solid circles). Here, as noted on the Figure, there is a rather strong difference in the correlation between the summer and fall data. The linear correlation coefficient, (r) is only 0.18 for the summer months, indicating little if any correlation, while the fall data (r = 0.8) are highly correlated. This is not easy to explain, with the type of

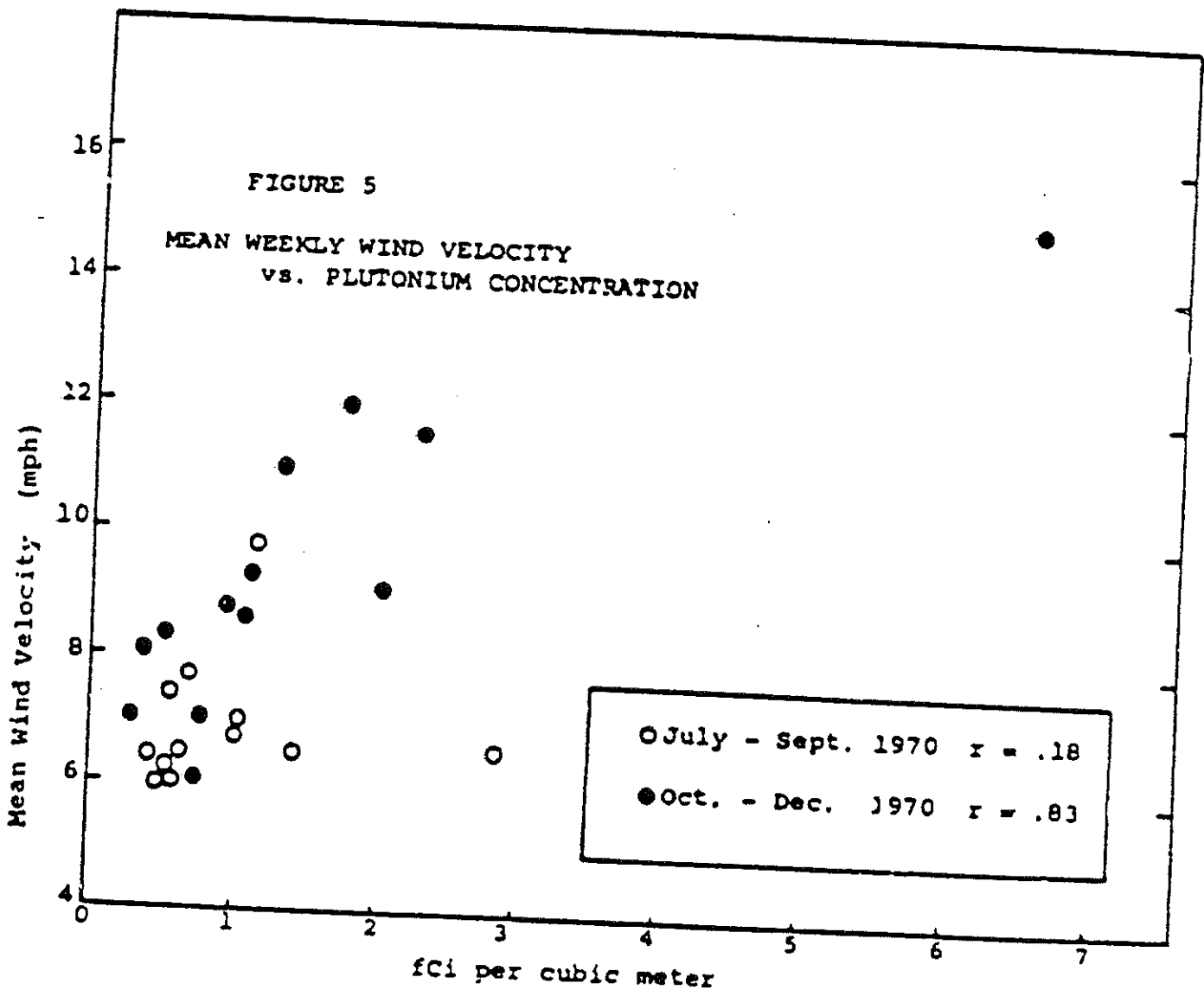

Fig. 5

sample and wind input available to us. It suggests to me, that in summer, when the winds are lower and less variable, the resuspension is probably more directly related to short term meteorological variables, not as yet obvious to us. In the fall, however, the good correlation between wind and plutonium concentration, even on this basis of average weekly samples, seems to be attributable to the higher average wind speeds. We can almost recognize the existence of a threshold at approximately 8 mph: only one of the summer samples averaged above 8, while all but three of those taken in autumn were above 8. Since even the summer samples are substantially above the fallout levels, it seems as though there may be two mechanisms involved in the resuspension, one operating below about 8 mph, and not obviously correlated, and another which results in good linear correlation, at mean winds above about 8 mph.

For completeness, I feel I must mention *resuspension factors*, although I really question the usefulness of this concept in context of the Rocky Flats situation. These factors are derived by dividing the ground deposit, into the air concentration, with care in the choice of units. For these types of radioactivity resuspension studies, we can use mCi/m^3 over mCi/m^2 . But, implicit in the use of these factors is the assumption that the air concentrations observed are derived or related to the soil concentrations. Since, in the area of our air sampling, the gradients in soil concentration were very steep, and we did in fact find substantial penetration of plutonium into the soil, the simple use of the resuspension factors is of doubtful value. At any rate, at the site of our air sampler, using the soil data reported in HASL-235² a resuspension factor of about 10^{-9} m^{-1} was calculated. In another experiment, which will not be completely discussed here, we pressed sticky paper to the soil surface, assuming that the fine particles which were retained might approximate the readily resuspendable portion of the soil and plutonium. Using the results from this sample as the denominator, the resuspension factor approached 10^{-6} . Both of these values are in the range of resuspension factors reported earlier from both experimental and theoretical considerations.

We have begun studies on the particle size of the airborne particulate, near the Rocky Flats plant. The size of the plutonium particles and whether or not they are attached to larger *host* particles are critical factors in finally determining whether or not this observed resuspension is a potential hazard to man. The initial work has been carried out under contract with Trapelo/West. Very preliminary results suggest that the *equivalent diameter* of the PuO_2 particles averaged less than $0.2 \mu\text{m}$. We believe, at this time, that the plutonium is associated with host particles of median diameter about $10 \mu\text{m}$.

Our present plans are to continue the air sampling at Rocky Flats, expanding to a few additional pumps, to define the downwind gradient of plutonium in the air, and to establish some data in the northern and southern directions. The studies of particle size of the resuspended plutonium will be continued and refined as some new and better equipment becomes available.

References

1. "Report on the Dow Rocky Flats Fire: Implications of Plutonium Releases to the Public Health and Safety," Colorado Committee for Environmental Information, Subcommittee on Rocky Flats, Boulder, Colorado, January 13, 1970.
2. P. W. Krey and E. P. Hardy, Jr., "Plutonium in Soil Around the Rocky Flats Plant," USAEC Report HASL-235, August 1, 1971.
3. "Plutonium in Airborne Particulates," Radiological Health Data and Reports, Vol. 12, No. 6, June 1971, p. 335, EPA - Office of Radiation Programs.
4. H. L. Volkov and M. T. Kleinman, "Radionuclides and Lead in Surface Air," USAEC Report HASL-243 (Appendix), July 1, 1971, p. C-1.
5. EURATOM Joint Nuclear Research Centre, ISPRA Establishment, Quarterly Report, Reproduced in USAEC Report HASL-239, January 1, 1971, p. III-40.

LOG-NORMAL ANALYSIS OF DATA FOR PLUTONIUM IN THE OUTDOORS

by

D. E. Michels
Dow Chemical Co.
Rocky Flats Division
Golden, Colorado

ABSTRACT

Detected amounts of plutonium are distributed log-normally for most groups of samples. When data are plotted on probability paper, sharp distinctions may sometimes be made between the background distribution and increments from a local source.

Because the detected amounts of plutonium are not distributed normally, arithmetical averaging of detected amounts is not valid. Similarly, composited samples from large areas yield analyzed values which cannot be interpreted. Additionally, the proper standard deviation for background samples refers to a ratio of concentrations rather than to an increment as is commonly reported.

Introduction

Since starting to deal with data about plutonium in the outdoors I have lamented both the variability of the data and the paucity of precise conclusions that have been offered concerning the distribution of plutonium. Of course, part of that variability results from the nature of the dispersion. Not only must we live with that but it is the very thing we must describe. One tool that so far seems very powerful in handling plutonium data is probability paper. Today I wish to explain the technique, to demonstrate how it is applied to real data, and most of all, to show that the data truly can support concise conclusions.

Discussion

First, let's look at some alternative ways of plotting the data while using a statistical point of view. Any group of data will have an average value and a degree of variation. But we may have to search a little to find the best way of quantifying both the average and the variation. This first slide shows four ways to describe the same data, but the four are not equally useful. The graph in the upper left represents the analytical data for plutonium

that we have to deal with. The data contain an excess of large values over what a normal distribution would contain. Actually, non-normal distributions for the analytical values should be expected for trace materials anywhere since zero concentration is an impossible boundary. Clearly, when a one-sigma or a two-sigma distance from the average value turns out to be a negative concentration, our point of view should receive some serious adjustment.

If the data are truly homogeneous, then some mathematical transformation exists for which the transformed values are distributed normally. Finding that proper transformation is essential. The graph in the lower left (Fig. 1) corresponds to the data after a proper transformation has been made. Thus transformed, the data are distributed normally and then (but only then) do our notions about averages and standard deviation become appropriate. Trying to plot a Gaussian bell-shaped curve from empirical data is expensive since several tens to hundreds of data are required for any kind of precision in locating the actual position of the curve. However, by adjusting the scales of our plots we can get along with fewer data. The graph in the lower right (Fig. 1) involves cumulative percent and a few tens of data points will define it nicely, although its curved shape leaves much room for gentlemanly disagreements about whether deviations from a true sigmoid shape may be meaningful.

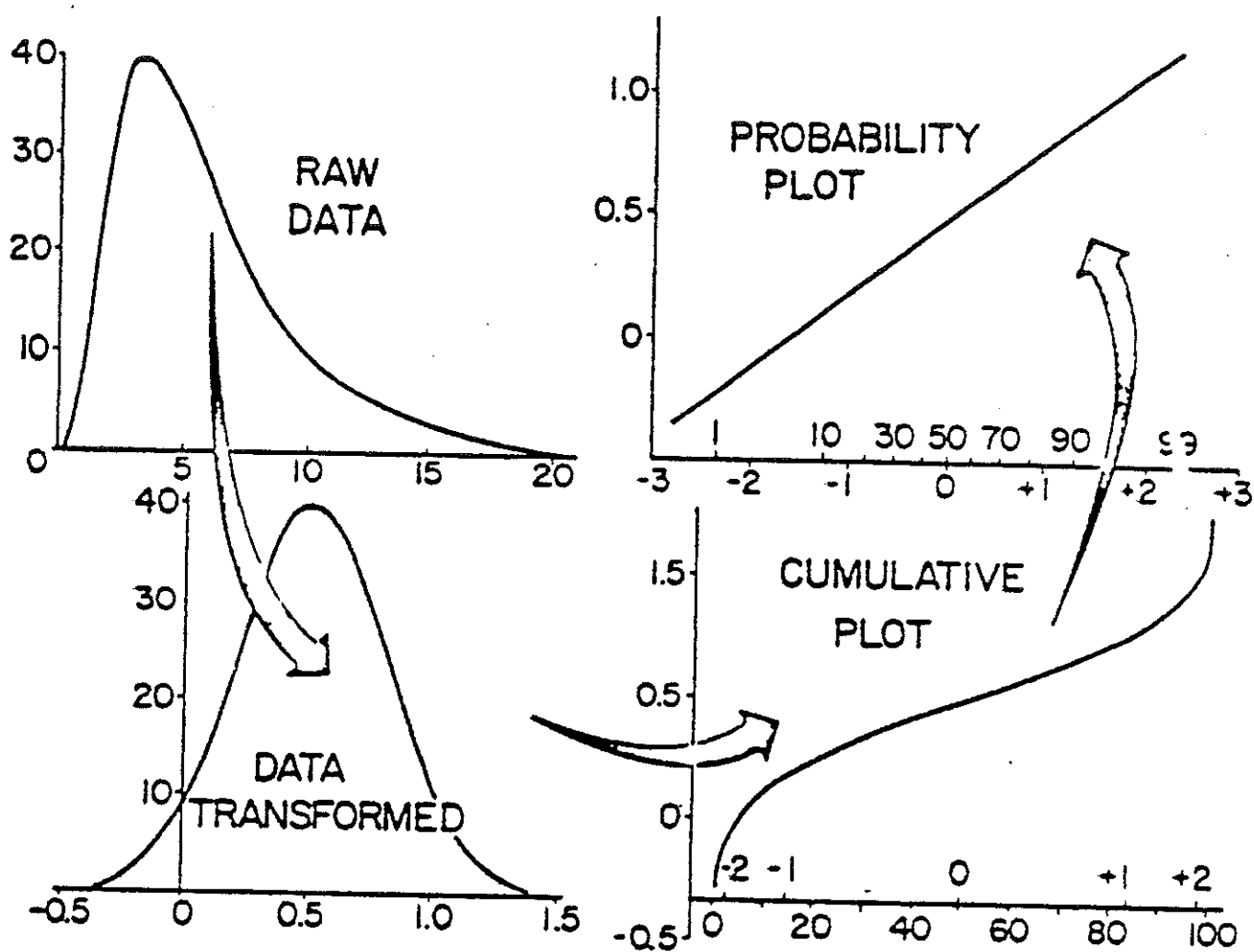

Fig. 1

The graph on the upper right (Fig. 1) is the kind I wish to focus on throughout the rest of this talk. It is derived from the lower right graph by replacing the cumulative percent axis with a probability scale. The probability scale is one which is linear in units of standard deviation rather than in units of cumulative percent.

There are four very considerable advantages in using this kind of plot. First, the plot will be linear when the transformation of the data does yield a standard distribution. Second, the question of linearity may become answerable with as few as ten or twelve data points (and with twenty data points one can acquire some real confidence). Third, the mean value for the data is given by the zero-sigma intercept, which lies in the middle of the array of plotted points. Fourth, the slope of the array is the standard deviation. Primarily, this plot is a test for assumptions we make about the data. The linearity checks whether we made good choices for the transformation and for the distribution type. If linear, the plot gives directly the two most important statistical parameters, mean value, and standard deviation. Some convenient

graph papers are available commercially which have a normal (Gaussian) probability scale along the horizontal axis, the vertical axis is variously linear or logarithmic. Exotic (non-Gaussian) distributions as well as normal ones are conceivable, and this technique applies to them all with equal validity. Our job is to find the combination of distribution type and data transformation which yield a straight line array. Many sets of geochemical data have been found to yield linear plots when a logarithmic transformation is combined with a Gaussian probability scale and that is the combination I will discuss hereafter. The distribution is commonly called log-normal.

Before we go further into log-normal plotting of data, I want to introduce a second concept which also can be answered by graphical techniques. Multiple sources of plutonium result in overlapping distribution patterns and part of our job is to find the limits of the overlap. Local sources like Rocky Flats and Los Alamos are superimposed on the world-wide fallout pattern, but the world-wide pattern is itself a composite. In order to describe accurately the geographic limits of local

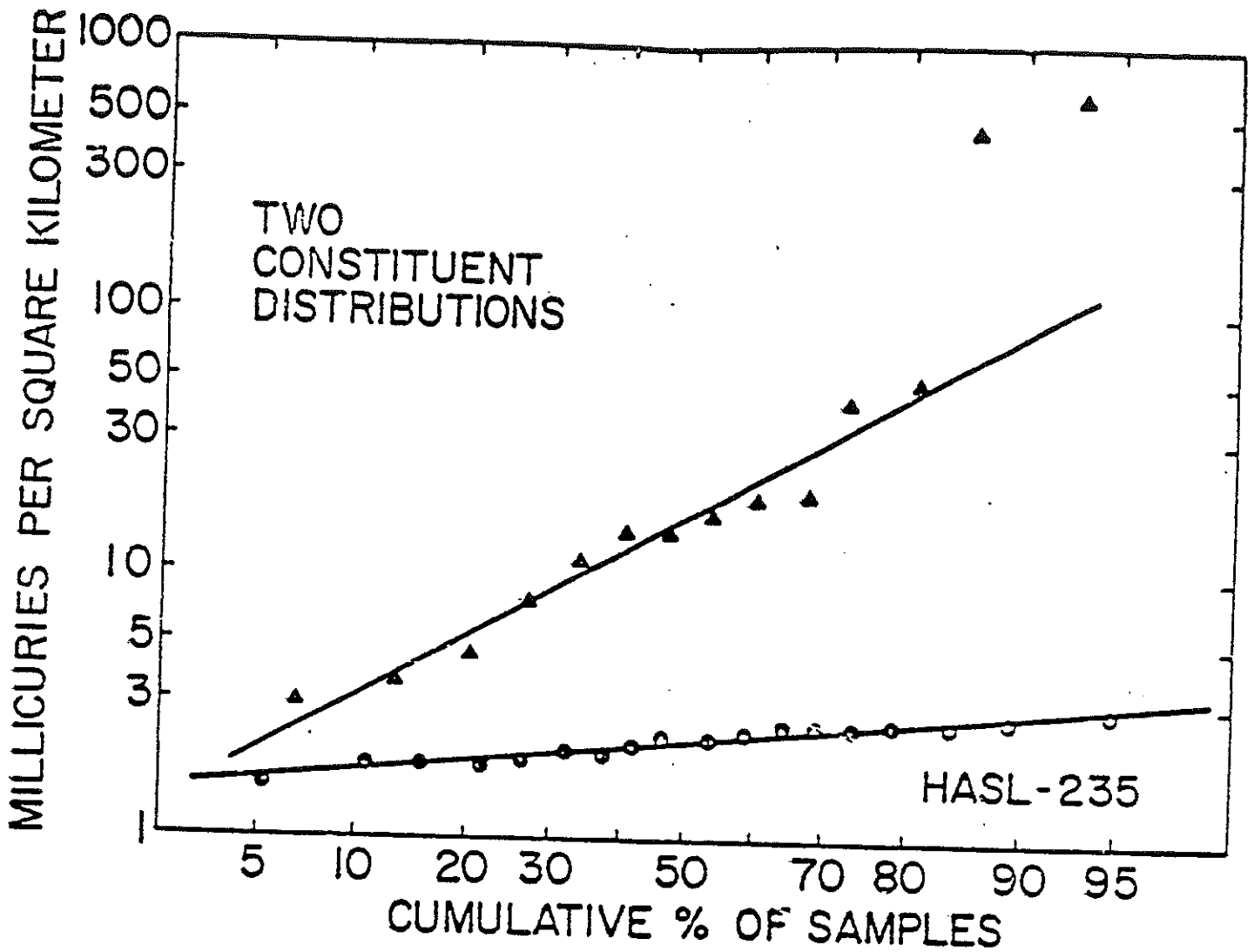

Fig. 3

others that I have studied, it can be shown that treating the analytical data as *normally distributed* is simply not valid. Therefore, conclusions based on averaging the analytical values can be seriously in error.

Which transformation of the data is best can be determined only by trial and error. Logically, we cannot prove that any transformation is proper, but we can show when a particular transformation is adequate. Similarly, we can show that making no transformation is sometimes inadequate. Figure 4 shows the results from testing eight sets of plutonium data and one set of ^{90}Sr data for distribution type, arithmetic or logarithmic. A W-test was used to estimate the probability that the assumed distribution is adequate. In all cases the groups of data show a high probability of being log-normally distributed. In half of the sets the arithmetic-normal distribution also has a high probability of being correct, but in the remaining four cases a presumption of arithmetic-normal distribution is not warranted. The presumption of log-normal distribution is never a bad presumption and is never worse than the presumption of arithmetic-normal. Often it is

PROBABILITIES OF DISTRIBUTION TYPES

Data	P(normal)	P(Log-normal)
Denver Fallout	0.099	0.91
Italian ^{90}Sr	0.74	0.90
Denver Background (HASL)	0.78	0.78
Santa Fe Background	0.17	0.75
Rocky Flats Anomaly (HASL)	0.059	0.63
Italian Pu	0.032	0.54
Rocky Flats Anomaly (CCEI)	0.000001	0.45
Denver Air	0.46	0.37

Fig. 4

contamination, as well as to take inventory of the plutonium we need methods which can clearly distinguish superimposed distributions. Graphical methods are preferred for this last task since describing the edges of anomalous areas will involve subjective decisions. Again, probability plots are useful. Let's look at an example.

The data shown in Fig. 2, are from Health and Safety Laboratory (HASL) Report 235, and involve 33 soil samples taken in the Denver area. First, the data are arranged in rank order and a percentile is computed for each datum. When the plotting is complete we see two distinct legs and conclude either that the data are not distributed log-normally or that they are not a homogeneous collection. But we don't really expect the data to be homogeneous anyway since the reason the samples were taken in the first place was to find out how much of an effect Rocky Flats was having on the plutonium inventory near Denver.

From the plot we see that the two legs intersect near the value 3.0 mCi/km². Using the 3.0 mCi/km² value as a criterion, the 33 data can be segregated into two

(unequal) sub-groups, each of which can be tested for homogeneity by replotting as two independent distributions. The linear plots in Fig. 3 affirm both that the log-normal plot is appropriate and the two groups are homogeneous. From the straight lines we can estimate mean values and standard deviations. Additionally, the successful separation of the bulk data tells us that the value 3.0 mCi/km² is a good boundary contour for the Rocky Flats anomaly. Only a small portion of contaminated samples would show a value that low and the background values have a fair chance of being that high.

An important element of this kind of data analysis is to treat the data as groups not as individuals. Indeed, any single analytical value should be considered as without meaning when by itself. All meaning comes from the relationships among values. Thus, distributions are the primary objects to be described.

Making transformations of analytical data is an uncommon practice apparently, but it is both useful and valid. For broadly distributed groups of data such as the higher content sub-group of the HASL data, and also

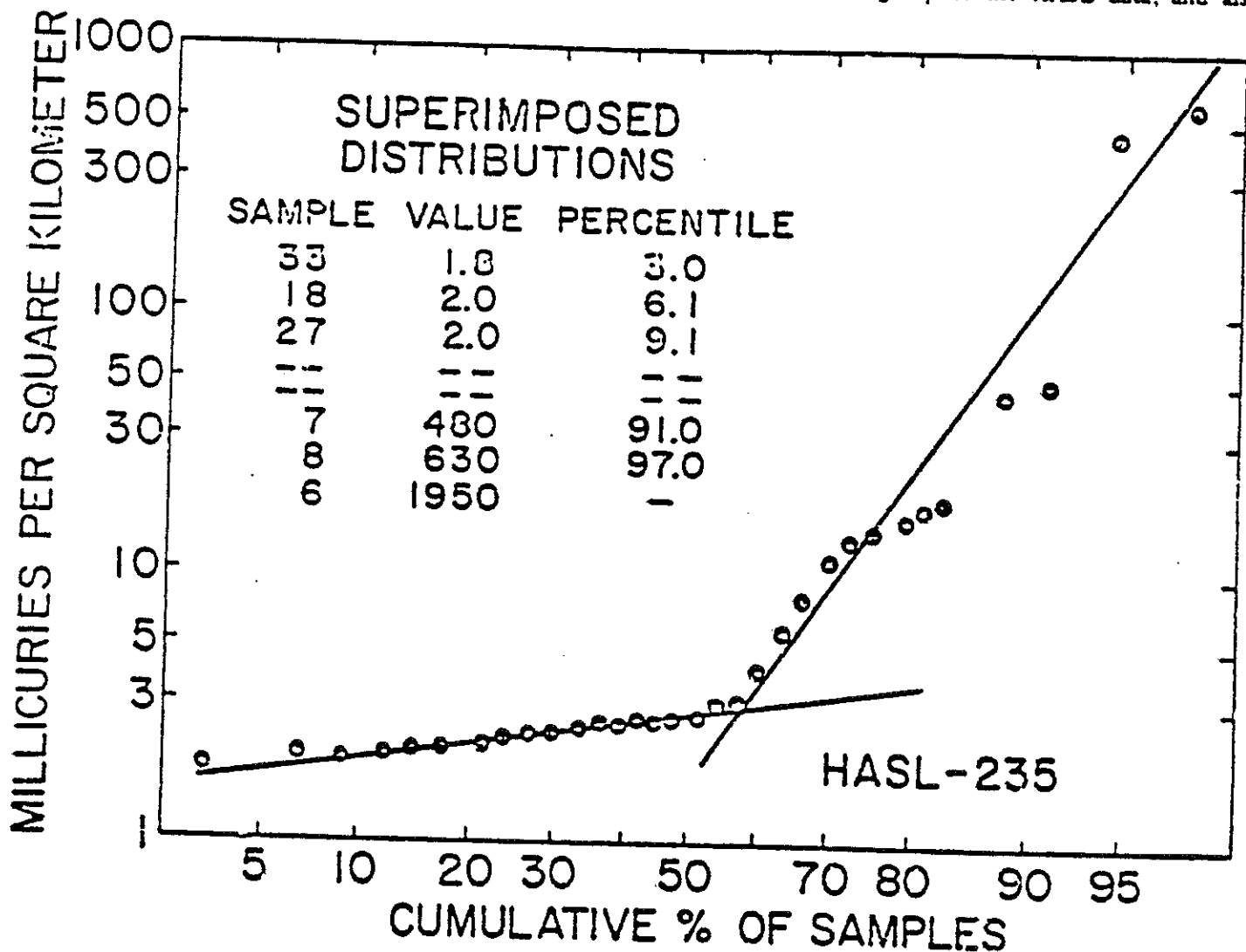

Fig. 2

much better, so that in cases where we do not know what distribution type actually exists presuming a log-normal distribution is a good strategy. When the data are quite variable a (logarithmic) transformation is definitely necessary.

When data are transformed we should be careful about our interpretation of the term *average*. The mean values indicated by the 50% intercepts are called geometric-mean values. They correlate with the analytical values in that the geometric mean is the antilog of the arithmetic mean of the logarithms of the analytical values. Thus, we should take logarithms before taking averages.

For the case of log-normal distributions, we also should carefully examine our interpretation of the standard deviation. The unit of slope in a log-normal plot involves a logarithmic increment. Thus, the standard deviation is a multiplier of the geometric-mean value. It is not an increment of the analytical values.

One more important point concerns the slopes

associated with log-normal plots. The slope is related to the components of variance as shown in Fig. 5. Since the variances are additive, large variance in either sampling or analysis may mask the variance of the data.

An example in which this problem seems to exist is from data reported by Colorado Committee for Environmental Information (CCEI) (Fig. 6). When plotted on log-probability paper the data yield a single linear array of high slope. The singularity of slope suggests that the data are homogeneous. But geographically the data involve areas at Rocky Flats which lie both inside and outside the contaminated area. Hence, the CCEI data should be expected to show two legs just as HASL data did.

Why does the CCEI data not demonstrate a local increment of plutonium? Plotting it together (Fig. 7) with the HASL data suggests that the variances due to analytical and sampling problems may have masked the fundamental variances. The shallow samples of CCEI yielded only 60% as much plutonium as did the HASL background samples. The CCEI standard deviation is more than nine times as large as that for HASL background, and about the same as the HASL standard deviation for the Rocky Flats anomaly. It would seem that the variance associated with the CCEI data is too large to resolve the underlying variance of the background. Consequently, the data fail to demonstrate existence of a local source of plutonium.

$$(\text{SLOPE})^2 = \sigma^2 = \sigma^2 + \sigma^2 + \sigma^2$$

Noise Signal

Fig. 5.
Components of standard deviation.

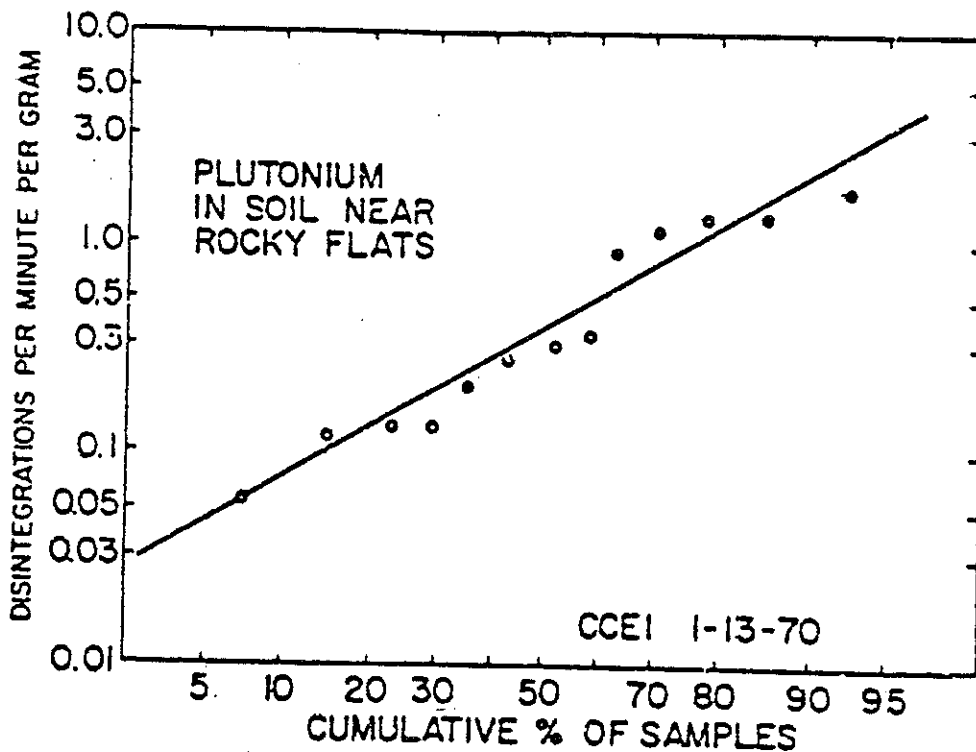

Fig. 6

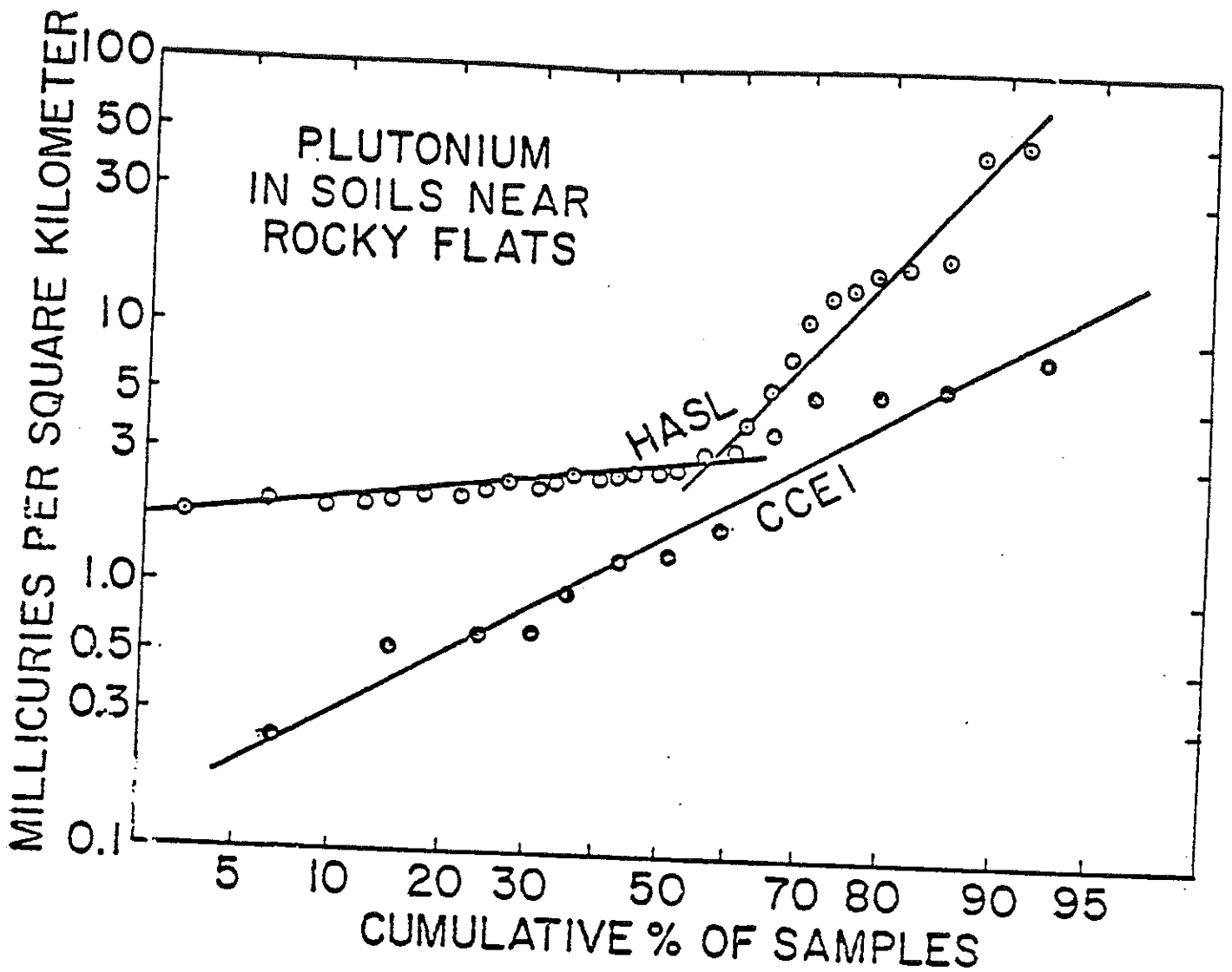

Fig. 7

To summarize, (Fig. 8) I have tried to show how a graphical technique can be used to unscramble and thus help interpret data about plutonium in the outdoors. Most groups of data fit log-normal distributions better than arithmetic distributions. Additionally, when data are plotted on log-probability paper one can decide whether the data come from a single distribution or from overlapping distributions. A graphical method is preferred for unscrambling distributions which overlap.

Slope of the plots is a key parameter, but the slope can become so inflated that the analytical values are

useless. Sampling and sample-splitting, particularly, are sources of variance more important than analytical difficulties.

When a logarithmic transformation is appropriate, the proper mean value of the data is a geometric mean and the corresponding standard deviation has the property of being a multiplier rather than an increment.

Although the data on plutonium in the outdoors tend to range greatly, the data often can support interpretations that are more precise than many reported so far.

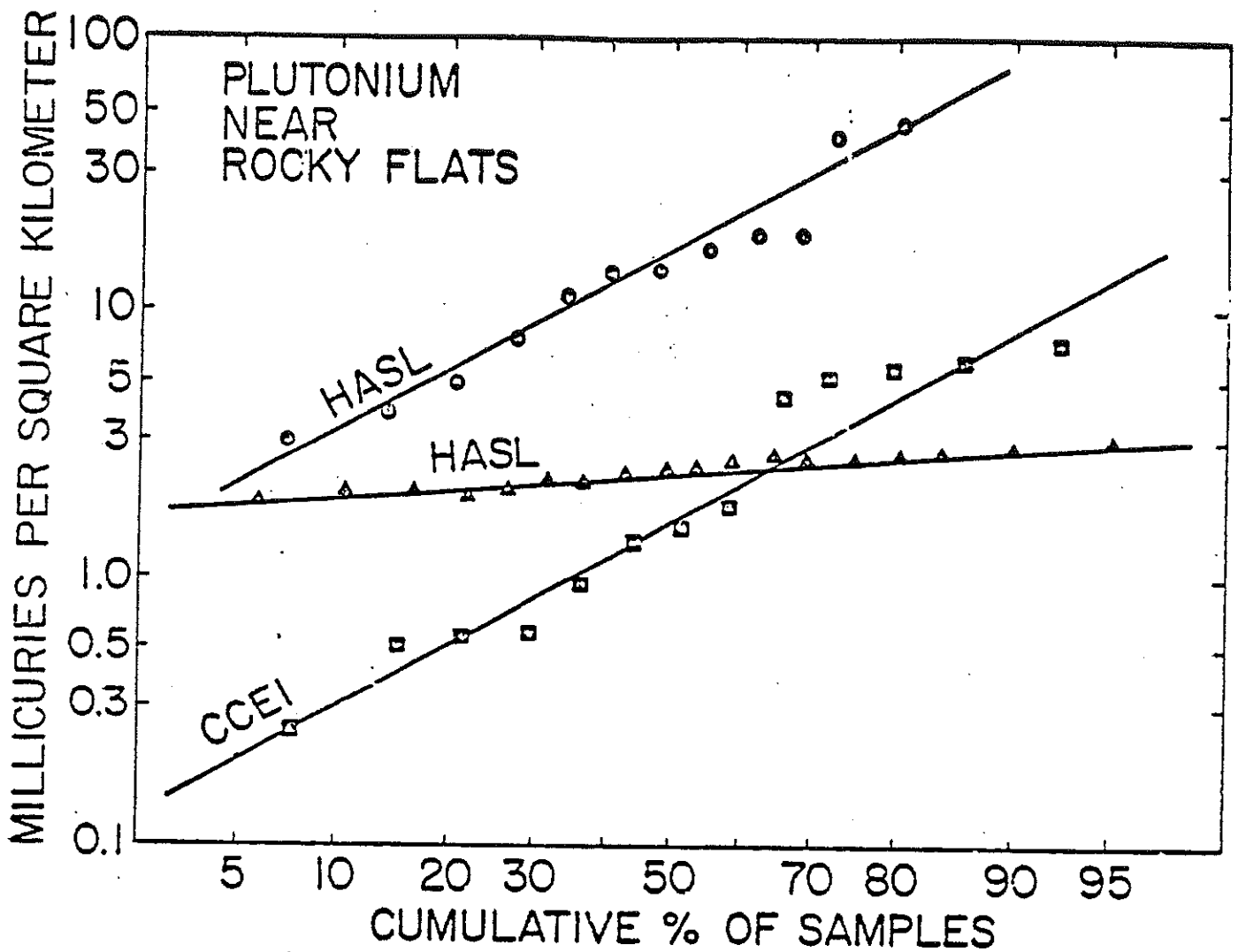

GRAPHS ARE GOOD
 LOG-NORMAL FITS
 WATCH OUT FOR VARIANCE
 MORE PRECISE STATEMENTS ARE POSSIBLE!

Fig. 8.

SOME THOUGHTS ON PLUTONIUM IN SOILS

by

J. W. Healy
Los Alamos Scientific Laboratory
University of California
Los Alamos, New Mexico

ABSTRACT

The resuspension of particles by wind or mechanical disturbance is one of the major routes of potential intake from plutonium in soils. The actual air concentrations resulting from resuspension depend upon many variables including the characteristics of the source, the degree of disturbance, the nature of the terrain, and the meteorological dispersion and deposition processes operating. Although little data are available to characterize these variables and to provide a general solution, some of the factors involved are discussed.

The title of this paper took very careful negotiations with the sponsors of this symposium. I lost on only one point - I wanted to include the words "Random Thoughts" since this would have given me complete freedom to discuss almost any subject. However, upon further consideration, I find the title to be a little embarrassing since it is very broad and, at the same time, it implies that I might have some worthwhile thoughts to convey.

I would like to direct my remarks toward a few of the factors which seem to be of importance in the resuspension of materials on the ground in order to permit focusing on the types of experimental data and environmental measurements which are needed. This is doubly important for plutonium since the current evidence indicates that the other major mechanisms for intake, such as ingestion or reconcentration through the food chain, do not play as vital a role with plutonium as with many of the other isotopes. Thus, inhalation has been, and still seems to be, the mode of intake of importance when considering plutonium in the environs.

Before discussing the normal concept of resuspension as a mechanism to produce general air concentrations in a region, we should consider other implications of the potential for inhalation. Thus, entry into an area having plutonium in the soil can result in a transfer of some of the material to the body or clothing. Later movements or removal of the clothing with subsequent handling can result in some of this material becoming airborne to produce localized air concentrations. Studies with

contaminated clothing have indicated that significant transfer can be accounted for,¹ although the first step, transfer from the surfaces to the clothing, has been poorly investigated. Similar mechanisms can occur with other objects such as tools, or even the family pet, which are taken into the area. While not of primary concern in dealing with the safety of people, we must consider the possible intake by grazing or burrowing animals since they are more closely tied to the soil than man and could have significant intake through this close association. Present evidence indicates that this is not a problem in transmitting the plutonium to man because the uptake in organs used for food is small and the uptake from the GI tract of man is also small so that these two factors provide a strong discrimination against the plutonium in soils. These possible intake mechanisms are subject to many of the same variables as those to be discussed in the resuspension mechanisms and are mentioned at this point to remind us that we must consider all possible sources of inhalation and not concentrate exclusively on the single mechanism as I shall do through the remainder of this paper.

Resuspension and the general air concentration resulting therefrom are very complicated phenomena which will vary widely depending upon the nature of the contaminant (such as particle size), the characteristics of the surface or the soils involved, the terrain and vegetative cover, and the particular meteorological conditions at any time. Most studies of this process with radioactive materials have used a simplifying concept of a resuspension

factor in expressing the results. This factor is the ratio of the air concentration at a given location to the quantity of material per unit area on the ground at that location and has been measured under conditions of normal wind actions as well as with added mechanical disturbance. While this concept can be useful in defined circumstances, it gives little insight into the nature of the processes involved so that it is difficult to apply this knowledge to other areas or forms of contaminant. For example, it does not account for the size of the area or the possible existence of more highly contaminated areas upwind. Estimates of the dispersion and deposition characteristics of material from a uniform source emitting to the atmosphere indicate that significant concentrations of respirable size particles can originate from miles away. The resuspension factor does not account for dispersion by the atmosphere or for changes in the rate of resuspension with, for example, wind speed or changes in atmospheric stability.

A different, and somewhat more complex, approach is to consider the mechanisms of resuspension separately from those of deposition and dispersion in the atmosphere. In this way each point of the area can be considered as a source of airborne material and the concentration at any point downwind can be calculated by use of the correlations derived from atmospheric dispersion and deposition studies and by integration over the area of deposition. Similarly, the magnitude of the pickup rate (or fraction resuspended per unit time) can be studied by measuring the concentration downwind from a source on the ground under various conditions of natural or artificial disturbance.

This approach is certainly not as simple as that of the resuspension factor, but by carrying out the measurements in such a way as to gain information on the characteristics of the source, the meteorological conditions and the airborne concentrations, one can account for many of the variables and from these make an estimate of the resuspension concentrations which will occur for different areas in which the size, distribution of material and particle size may differ. It must also be admitted that, at the present time, there seems to be little quantitative data in the literature which would permit the making of reliable estimates under any condition. Further, there are processes which operate over relatively small areas, such as the small whirlwinds frequently encountered in desert country, which could provide a separate source of resuspension which would not be adequately covered by a more general large area study.

The work of the soil scientists, particularly Bagnold² and Chepil,^{3,7} have given considerable insight into the mechanisms of movement by winds, particularly under conditions of gross movement such as occurs at high wind speeds over desert sands or plowed fields. Their observation of a threshold velocity of the wind speed for this type of movement is widely recognized as is their demonstration of the stability of fine powders of uniform particle size even under relatively high wind speeds. However, it is not clear that these observations are completely

applicable to the problem of concern here, where relatively low concentrations moving as suspended materials are of interest. For example, some observations have been made of air concentrations of zinc sulphide particles downwind from a single source on the ground at wind speeds as low as 1.3 m/sec.⁸ At least we should design our experiments and measurements to indicate the validity of such concepts.

The question of the behaviour with time of the deposited material has many practical aspects but few answers. For example, aggregation of the deposited particles with soil particles will result in differences in behaviour depending upon the soil particle sizes, degree of natural aggregation and the stability of the aggregate under the disturbances expected. We cannot expect a permanent fixation on soil particles since Chepil has noted that there is a continuous production of small particles, at least in agricultural soils, under the influence of erosive forces, but the net effect of such aggregation may well decrease the overall susceptibility of originally fine particles to movement into the atmosphere. The gradual movement of the deposited material into the soil profile by washing or alternate freezing and thawing will decrease the surface layers which are most subject to disturbance. Seasonal variations in vegetative cover, moisture and even in meteorological conditions will affect the possibility of resuspension.

One can visualize, for this purpose, two limiting conditions. The first corresponds to a fresh deposit where the material is exposed on the surface of the ground and other surfaces with a particle size distribution characteristic of the deposited material and independent of the size distribution of the soil particles. Under these conditions, the deposited material is readily available and can be described in terms of the quantity per unit area. In the second limiting condition, the deposited material has weathered and become intimately associated with, at least, the top layers of the soil profile perhaps even to the extent of having similar effective particle sizes through the processes of aggregation, erosion, etc. Here, only the top layer is subject to resuspension, with the definition of the top layer dependent on the degree of mechanical disturbance or, perhaps, the wind speed under natural conditions. In this case the amount resuspended is closely related to the natural dust from the surface and the concentration in the soil would seem to be of most interest. Following a deposition we would expect a transition period from the first limiting condition to the second over a period of time along with spreading over a larger area due primarily to the processes of surface creep and saltation in barren areas but also to redeposition of smaller particles in vegetated regions. The time required for this transition is indeterminate and probably depends upon the characteristics of the individual area. Some measurements have been made in arid regions which indicate that the initial air concentrations decrease with a half-life of about one to two months, however, it is not clear that these correlations are not partially associated

with other factors such as seasonal variations in wind direction, velocities or stabilities. At the moment, it appears likely that a decrease in the resuspension will occur as a deposit ages but data do not seem adequate to characterize the rate of decrease or the time to attain a final, reasonably steady state, particularly when differences in soils, terrain, vegetation, etc. from one region to another are considered.

The above considerations also bear on the question of how we should measure and report the data. There is much historical precedent for the quantity per unit area, such as $\mu\text{Ci}/\text{m}^2$ and this seems appropriate for the initial period following deposition. However, when we sample the soils for analysis, the result is measured in concentrations such as $\mu\text{Ci}/\text{g}$. Eric Fowler and his soils committee at the Nevada Test Site have suggested a standardization of terminology whereby the results are reported as quantity per unit area with a specification of the depth of the profile sampled and, if possible, a specification of the soil density. From these data it is possible to convert from one to another. For purposes of considering resuspension we are primarily interested in the top layer containing the contaminant and subject to disturbance. For practical reasons of sampling, it appears difficult to consider a layer less than about one centimeter. If we could, again, standardize on some such thickness, then the results would be meaningful in most cases and the decrease with time as the material penetrates into the soil could be considered in the studies of rate of resuspension. While on the subject of units, I would like to make a personal plea for some consistency in methods of reporting. We see air concentrations reported in $\mu\text{Ci}/\text{cc}$, $\mu\text{Ci}/\text{m}^3$, $\mu\text{Ci}/\text{m}^3$, etc. While I know that this is convenient for the author because of the lack of an exponent, I have considerable difficulty in making the necessary conversions to compare with other papers or with the standards, and I suspect that a few errors creep into the conclusions of other people from such mental conversions. It would, therefore, seem worthwhile to consider reporting our results in the same units as the standards.

There is one other consideration in the measurement of soils as connected to resuspension which I would like to mention. This is the fact that the processes involved tend to average the pickup from a relatively wide area. Thus, the real need in describing the ground deposition is not a point-to-point sampling but, rather, averaging over a significant area. This, of course, will affect the sampling strategy although I am certainly not prepared to fully define optimum area of sample size.

Finally, we have considered a few of the difficulties of relating air concentrations to soil concentrations. There are many more including the problem of soil drifting due to eddies, redeposition on a hard surface, and defining the characteristics of an actual source. While I believe that further studies of resuspension mechanisms are necessary to further define and control potential problems, I also question whether the quantity of material deposited is a useful parameter for control purposes. In view of the many variables involved in the resuspension process, it would seem that direct measurements of air concentrations would provide more direct and useful information than an equivalent amount of effort on soil measurement followed by extrapolation with many variables to air concentrations.

References

1. R. Butterworth and J. K. Donoghue, "Contribution of Activity Released from Protective Clothing to Air Contamination Measured by Personal Samplers," *Health Physics* 18, 4, 319-323, (April, 1970).
2. R. A. Bagnold, "The Physics of Blown Sands and Desert Dunes," Methuen and Co., Ltd., London, 1954.
3. W. S. Chepil, "Dynamics of Wind Erosion: I," *Soil Science*, 60, 305-320, 1945.
4. W. S. Chepil, "Dynamics of Wind Erosion: II," *Soil Science*, 60, 397-411, 1945.
5. W. S. Chepil, "Dynamics of Wind Erosion: III. The Transport Capacity of the Wind," *Soil Science*, 60, 475-480, 1945.
6. W. S. Chepil, "Dynamics of Wind Erosion: IV. The Translocation and Abrasive Action of the Wind," *Soil Science*, 61, 167-177, 1945.
7. W. S. Chepil, "Dynamics of Wind Erosion: V," *Soil Science*, 61, 257-263, 1946.
8. J. W. Healy and J. J. Fuquay "Wind Pickup of Radioactive Particles from the Ground" 2nd UN Geneva Conference P/391 USA, Pergamon Press, London.

ATTENDEES

- Robert E. Allen
Division of Operational Safety
U.S. Atomic Energy Commission
Washington, DC 20545
- I. Aoki
REECO
P.O. Box 1440
NTS - Mercury, NV 89023
- Robert E. Baker
Division of Operational Safety
U.S. Atomic Energy Commission
Washington, DC 20545
- Capt. William T. Bartlett
USAF Radiological Health Laboratory (AFLC)
Wright-Patterson Air Force Base
Dayton, OH 45433
- C. T. Bishop
Mound Laboratory
Monsanto Research Corporation
Miamisburg, OH 45342
- Wayne A. Bliss
Environmental Protection Agency
P.O. Box 15027
Las Vegas, NV 89114
- M. R. Boss
Dow Chemical Co.
Rocky Flats Division
P.O. Box 888
Golden, CO 80401
- Andre Bouville
United Nations
New York, NY 10017
- Howard Boyd
Lovelace Foundation
5200 Gibson Blvd., SE
Albuquerque, NM 87108
- J. F. Bresson
U.S. Atomic Energy Commission
Albuquerque Operations Office
P.O. Box 5400
Albuquerque, NM 87115
- L. W. Brewer
Sandia Laboratories
P.O. Box 5800
Albuquerque, NM 87115
- William C. Bright
Dow Chemical Co.
Rocky Flats Division
P.O. Box 888
Golden, CO 80401
- C. Austin Burch
U.S. Atomic Energy Commission
Albuquerque Operations Office
P.O. Box 5400
Albuquerque, NM 87115
- Percy E. Clemons
Gulf-United Nuclear Fuels Corporation
Research and Engineering Center
Grasslands Road
Elmsford, NY 10523
- John P. Corley
Battelle Northwest
P.O. Box 999
Richland, WA 99352
- Roger C. Dahlman
Oak Ridge National Laboratory
Building 3017
Oak Ridge, TN 37830
- Jared J. Davis
Office of Effects Evaluation
U.S. Atomic Energy Commission
P.O. Box 14100
Las Vegas, NV 89114
- Jack H. Doyle
AECOP-AEC
P.O. Box 5
Oak Ridge, TN 37830
- Gordon M. Dunning
Office of Environmental Affairs
U.S. Atomic Energy Commission
Washington, DC 20545
- C. E. Elderkin
Battelle Northwest
P.O. Box 999
Richland, WA 99352
- W. P. Ellis
U.S. Atomic Energy Commission
Washington, DC 20545
- R. J. Engleman
Division of Biology and Medicine
U.S. Atomic Energy Commission
Washington, DC 20545
- B. S. Evans
Colorado Department of Health
4210 11th Avenue
Denver, CO 80220
- Gordon C. Facer
Division of Military Application
U.S. Atomic Energy Commission
Washington, DC 20545
- William D. Fairman
Argonne National Laboratory
9700 South Cass Avenue
Argonne, IL 60439
- T. R. Folsom
Scripps Institution of Oceanography
University of California, San Diego
P.O. Box 109
La Jolla, CA 92037
- C. W. Francis
Oak Ridge National Laboratory
Building 2001
Oak Ridge, TN 37830
- Dave Freas
Battelle Columbus Laboratories
505 King Avenue
Columbus, OH 43201
- J. E. Frederick
U.S. Atomic Energy Commission
Washington, DC 20545
- Marvin C. Gaske
Advisory Committee on Reactor Safeguards
U.S. Atomic Energy Commission
Washington, DC 20545
- Carl C. Gamertsfelder
U.S. Atomic Energy Commission
Washington, DC 20545
- Christopher Gatreous
Lawrence Livermore Laboratory
University of California
P.O. Box 808
Livermore, CA 94550
- Eric Geiger
Eberline Instrument Corp.
P.O. Box 2108
Santa Fe, NM 87501
- A. S. Goldin
Harvard University
School of Public Health
665 Huntington Avenue
Boston, MA 02115
- Gerald Hamada
Teledyne Isotopes
4062 Fabian Street
Palo Alto, CA 94303
- Stanley E. Hammond
Dow Chemical Co.
Rocky Flats Division
P.O. Box 888
Golden, CO 80401

Edward P. Hardy, Jr.
U.S. Atomic Energy Commission
New York Operations Office
376 Hudson Street
New York, NY 10014

John H. Harley
Health and Safety Laboratory
U.S. Atomic Energy Commission
376 Hudson Street
New York, NY 10014

A. J. Hazle
Colorado Department of Health
4210 11th Street
Denver, CO 80220

Vernon F. Hodge
Scripps Institution of Oceanography
University of California, San Diego
P.O. Box 109
La Jolla, CA 92037

Edward J. Jaseewsky
U.S. Atomic Energy Commission
Chicago Operations Office
9800 South Cass Avenue
Argonne, IL 60439

James E. Johnson
E. I. DuPont SRP
Bldg. 735-A
Aiken, SC 29801

H. Kayuha
REECO
P.O. Box 1440
NTS - Mercury, NV 89023

Maj. Kurt M. Lammers
Kirtland Air Force Base
Albuquerque, NM 87117

Ernest J. Lang
Eberline Instrument Corp.
P.O. Box 2108
Santa Fe, NM 87501

Russell Lease
REECO
P.O. Box 1440
NTS - Mercury, NV 89023

Robert Lieberman
Environmental Protection Agency
Southeastern Radiological Health Lab.
P.O. Box 61
Montgomery, AL 36101

Carl L. Lindeken
Lawrence Livermore Laboratory
University of California
P.O. Box 808
Livermore, CA 94550

Craig A. Little
Dept. of Radiology and Radiation Biology
Colorado State University
Fort Collins, CO 80521

R. W. Lower
Dow Chemical Co.
Rocky Flats Division
P.O. Box 888
Golden, CO 80401

Don Majors
Kerr-McGee Corporation
P.O. Box 315
Crescent, OK 73028

William E. Martin
Battelle Columbus Laboratories
505 King Avenue
Columbus, OH 43201

C. H. Mauney
Sandia Corporation
2511 San Mateo, N.E.
Albuquerque, NM 87110

B. J. McMurray
Atlantic Richfield Hanford Company
P.O. Box 250
Richland, WA 99352

Rod Melgard
Trapelo/West
2030 Wright Avenue
Richmond, CA 94804

Clyde Michel
Dow Chemical Co.
Rocky Flats Division
P.O. Box 888
Golden, CO 80401

D. E. Michels
Dow Chemical Co.
Rocky Flats Division
P.O. Box 888
Golden, CO 80401

Carl R. Miller
Environmental Protection Agency
Radiation Office
Room 18-B-33, Parklawn Bldg.
Rockville, MD 20852

Raymond L. Miller
U.S. Atomic Energy Commission
Albuquerque Operations Office
P.O. Box 5400
Albuquerque, NM 87115

Jofu Mishima
Battelle-Northwest
622-R Bldg., 200-W. Area
Richland, WA 99352

Robert K. Mullen
EG&G
130 Robin Hill Road
Goleta, CA 93017

Randy Newton
Division of Construction
U.S. Atomic Energy Commission
Washington, DC 20545

Carol Oen
Ecological Sciences Division
Oak Ridge National Laboratory
Oak Ridge, TN 37830

Donald Paine
Dept. of Radiology and Radiation Biology
Colorado State University
Fort Collins, CO 80521

Stewart E. Poet
NCAR
P.O. Box 1470
Boulder, CO 80302

Jack R. Polson
Mason & Hanger - Silas-Mason Co., Inc.
P.O. Box 561
Burlington, IA 52601

Wilfred L. Pulzer
U.S. Atomic Energy Commission
Idaho Operations Office
P.O. Box 2108
Idaho Falls, ID 83401

Otto Raabe
Lovlace Foundation
5200 Gibson Blvd., SE
Albuquerque, NM 87108

William H. Rhoads
EG&G
130 Robin Hill Road
Goleta, CA 93017

Chester R. Richmond
Division of Biology and Medicine
U.S. Atomic Energy Commission
Washington, DC 20545

D. M. Robertson
Battelle Northwest
P.O. Box 999
Richland, WA 99352

Evan Romney
Laboratory of Nuclear Medicine
UCLA
904 Veteran Avenue
Los Angeles, CA 90024

John L. Russell
Environmental Protection Agency
Radiation Office
5600 Fishers Lane
Rockville, MD 20852

Robert K. Schulz
Dept. of Soil and Plant Nutrition
108 Hilgard Hall
University of California
Berkeley, CA 94720

George Schmel
Battelle Northwest
P.O. Box 999
Richland, WA 99352

J. D. Shaykin
U.S. Atomic Energy Commission
Albuquerque Operations Office
P.O. Box 5400
Albuquerque, NM 87115

Warren E. Sheehan
Mound Laboratory
Monsanto Research Corporation
Miamisburg, OH 45342

Col. Buren Shields
FC/DNA, FCWD
Sandia Base
Albuquerque, NM 87115

C. W. Sill
U.S. Atomic Energy Commission
Idaho Operations Office
P.O. Box 2108
Idaho Falls, ID 83401

Alvin E. Smith
Atlantic Richfield Hanford Company
P.O. Box 250
Richland, WA 99352

James Stearns
Dow Chemical Co.
Rocky Flats Division
P.O. Box 888
Golden, CO 80401

W. L. Stevens
Sandia Laboratories
P.O. Box 5800
Albuquerque, NM 87115

Howard A. Storms
Vallecitos Nuclear Center
General Electric Company
Pleasanton, CA 94566

N. A. Tahrir
Environmental Protection Agency
P.O. Box 15027
Las Vegas, NV 89114

Charles W. Thomas
Battelle Northwest
P.O. Box 999
Richland, WA 99352

Michael Thommes
Argonne National Laboratory
9700 South Cass Avenue
Argonne, IL 60439

Michael W. Tiernan
U.S. Atomic Energy Commission
Richland Operations Office
P.O. Box 550
Richland, WA 99352

Joseph F. Tinney
Lawrence Livermore Laboratory
University of California
P.O. Box 808
Livermore, CA 94550

Harold Tao
Eberline Instrument Corp.
P.O. Box 2108
Santa Fe, NM 87501

W. Twenhofel
United States Geological Survey
Federal Bldg.
Denver, CO 80202

Gerald Ulrikson
Ecological Sciences Division
Oak Ridge National Laboratory
Oak Ridge, TN 37830

Allen M. Valentine
Kerr-McGee Corporation
Kerr-McGee Building
Oklahoma City, OK 73102

Herbert L. Volchok
U.S. Atomic Energy Commission
New York Operations Office
376 Hudson Street
New York, NY 10014

Stanley Waligora
Lovelace Foundation
5200 Gibson Blvd., SE
Albuquerque, NM 87108

E. D. Walker
Vallecitos Nuclear Center
General Electric Company
Pleasanton, CA 94566

E. C. Watson
Battelle Northwest
P.O. Box 999
Richland, WA 99352

George A. Welford
Health and Safety Laboratory
U.S. Atomic Energy Commission
376 Hudson Street
New York, NY 10014

Robert A. Wessman
Trapezoid/West
2030 Wright Avenue
Richmond, CA 94804

J. F. Wilging
Dow Chemical Co.
Rocky Flats Division
P.O. Box 888
Golden, CO 80401

Kai M. Wong
University of California, San Diego
Scripps Institution of Oceanography
P.O. Box 109
La Jolla, CA 92037

Robert E. Yoder
Lawrence Livermore Laboratory
University of California
P.O. Box 808
Livermore, CA 94550